

AdaptaFlow™ 5000

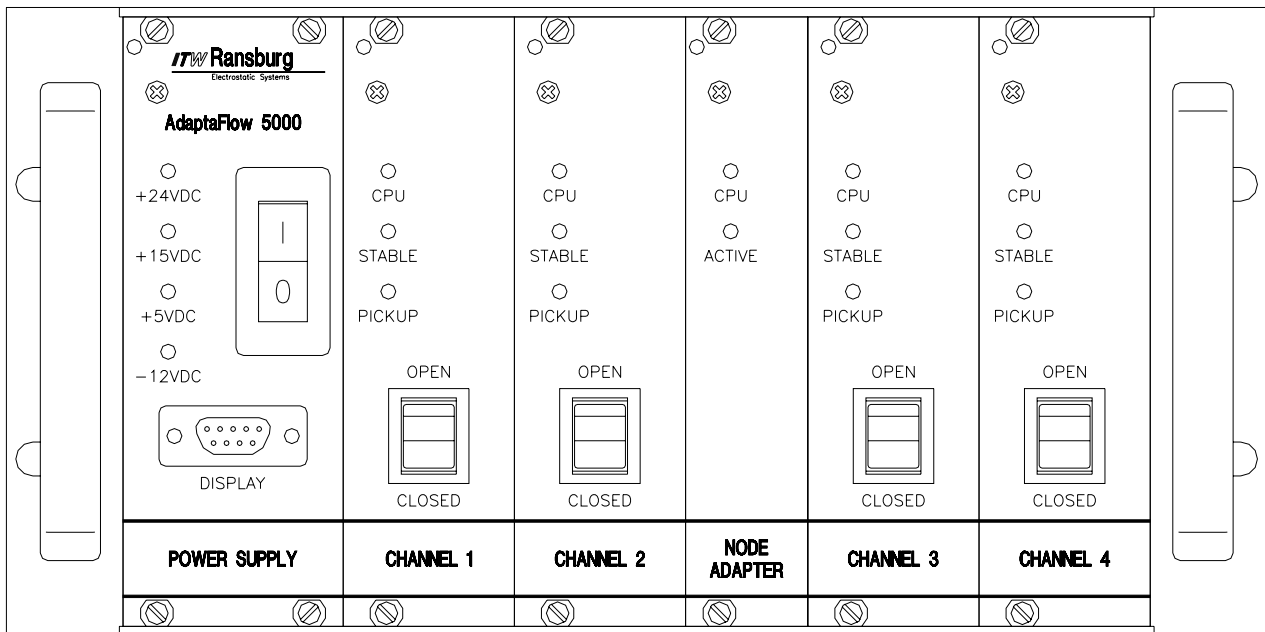

IMPORTANT: Before using this equipment, carefully read **SAFETY PRECAUTIONS**, starting on page 1, and all instructions in this manual. Keep this Service Manual for future reference.

Service Manual Price: \$30.00 (U.S.)

NOTE: This manual has been changed from revision **LN-9219-00.1** to revision **LN-9219-00.2**. Reasons for this change are noted under "Manual Change Summary" inside the back cover of this manual.

CONTENTS

| | PAGE |
|--|--------------|
| SAFETY: | 1-3 |
| SAFETY PRECAUTIONS..... | 1 |
| HAZARDS/SAFEGUARDS..... | 2 |
| INTRODUCTION: | 4-11 |
| GENERAL DESCRIPTION..... | 8 |
| STAND-ALONE ADAPTAFLOW 5000..... | 9 |
| ENVIRONMENTAL/PHYSICAL SPECIFICATIONS..... | 10 |
| ELECTRICAL SPECIFICATIONS..... | 10 |
| FLOWMETERS..... | 11 |
| INSTALLATION: | 12-33 |
| ELECTRICAL CONNECTIONS..... | 12 |
| CHANNEL CARD SETUP..... | 16 |
| HARD WIRE CONNECTIONS FOR PID CONTROL..... | 17 |
| POWER SUPPLY CARD SETUP..... | 18 |
| BUSBOARD SETUP..... | 18 |
| FLOWMETER..... | 19 |
| FLOWMETER SENSORS..... | 22 |
| 76400 DISPLAY / CONTROL UNIT..... | 30 |
| STAND-ALONE CONTROL UNIT..... | 32 |
| OPERATION: | 34-35 |
| MONITOR MODE..... | 34 |
| PID CONTROL MODE..... | 34 |
| LINEARIZER OPERATION..... | 35 |
| PROGRAM CONTROL: | 36-41 |
| COMMUNICATION PROTOCOL..... | 36 |
| VARIABLE DEFINITIONS..... | 37 |
| PC CONTROL USING THE GR3000 PROGRAM..... | 41 |
| 76400 DISPLAY / CONTROL UNIT: | 42-63 |
| PROGRAM MENUS..... | 42 |
| GENERAL OPERATION..... | 44 |
| F1 - ACTION DISPLAY..... | 45 |
| F2 - SINGLE CHANNEL DISPLAY..... | 46 |
| F3 - RATIO DISPLAY..... | 50 |
| F4 - PROGRAMMING..... | 51 |
| F5 - SEARCH CHANNELS..... | 59 |
| F6 - UTILITY FUNCTIONS..... | 59 |
| 1 - ACTION RATIO..... | 61 |
| 2 - QUICK PROGRAMMING..... | 62 |

CONTENTS (Cont.)

| | PAGE |
|---|--------------|
| MAINTENANCE: | 64-71 |
| FLOWMETER..... | 64 |
| TROUBLESHOOTING GUIDE..... | 68 |
| PARTS IDENTIFICATION: | 72-73 |
| ADAPTAFLOW 5000 PARTS LIST..... | 72 |
| WARRANTY POLICIES: | 74 |
| LIMITED WARRANTY..... | 74 |
| APPENDIX: | 75-86 |
| PAINT AND SOLVENT SPECIFICATIONS..... | 75 |
| VISCOSITY CONVERSION CHART..... | 76 |
| VOLUMETRIC CONTENT OF HOSE OR TUBE..... | 78 |
| TYPICAL SYSTEM CONTROL PANEL..... | 79 |
| CONTROL SYSTEM SCHEMATIC..... | 80 |
| STAND-ALONE CONTROL PANEL..... | 81 |
| ELECTRICAL SCHEMATIC, FIBER OPTIC SYSTEM..... | 82 |
| PNEUMATIC SCHEMATIC, STAND-ALONE UNIT..... | 83 |
| SERIAL PROGRAMMING COMMAND REFERENCE..... | 84 |

SAFETY

SAFETY PRECAUTIONS

Before operating, maintaining or servicing any ITW Ransburg electrostatic coating system, read and understand all of the technical and safety literature for your ITW Ransburg products. This manual contains information that is important for you to know and understand. This information relates to **USER SAFETY** and **PREVENTING EQUIPMENT PROBLEMS**. To help you recognize this information, we use the following symbols. Please pay particular attention to these sections.

A WARNING! states information to alert you to a situation that might cause serious injury if instructions are not followed.

A CAUTION! states information that tells how to prevent damage to equipment or how to avoid a situation that might cause minor injury.

A NOTE is information relevant to the procedure in progress.

While this manual lists standard specifications and service procedures, some minor deviations may be found between this literature and your equipment. Differences in local codes and plant requirements, material delivery requirements, etc., make such variations inevitable. Compare this manual with your system installation drawings and appropriate ITW Ransburg equipment manuals to reconcile such differences.

Careful study and continued use of this manual will provide a better understanding of the equipment and process, resulting in more efficient operation, longer trouble-free service and faster, easier troubleshooting. If you do not have the manuals and safety literature for your Ransburg system, contact your local ITW Ransburg representative or ITW Ransburg.



WARNING

- ▶ The user **MUST** read and be familiar with the Safety Section in this manual and the ITW Ransburg safety literature therein identified.
- ▶ This manual **MUST** be read and thoroughly understood by **ALL** personnel who operate, clean or maintain this equipment! Special care should be taken to ensure that the **WARNINGS** and safety requirements for operating and servicing the equipment are followed. The user should be aware of and adhere to **ALL** local building and fire codes and ordinances as well as **NFPA 33 SAFETY STANDARD, 1995 EDITION**, prior to installing, operating, and/or servicing this equipment.

WARNING

- ▶ The hazards shown on the following page may occur during the normal use of this equipment. Please read the hazard chart beginning on page 2.

| AREA Tells where hazards may occur. | HAZARD Tells what the hazard is. | SAFEGUARDS Tells how to avoid the hazard. |
|--|---|--|
| <p>Spray Area</p>  | <p>Fire Hazard</p> <p>Improper or inadequate operation and maintenance procedures will cause a fire hazard.</p> <p>Protection against inadvertent arcing that is capable of causing fire or explosion is lost if any safety interlocks are disabled during operation. Frequent power supply shutdown indicates a problem in the system requiring correction.</p> | <p>Fire extinguishing equipment must be present in the spray area and tested periodically.</p> <p>Spray areas must be kept clean to prevent the accumulation of combustible residues.</p> <p>Smoking must never be allowed in the spray area.</p> <p>The high voltage supplied to the atomizer must be turned off prior to cleaning, flushing or maintenance.</p> <p>When using solvents for cleaning:</p> <p>Those used for equipment flushing should have flash points equal to or higher than those of the coating material.</p> <p>Those used for general cleaning must have flash points above 100°F (37.8°C).</p> <p>Spray booth ventilation must be kept at the rates required by NFPA 33, 1995 Edition, OSHA and local codes. In addition, ventilation must be maintained during cleaning operations using flammable or combustible solvents.</p> <p>Electrostatic arcing must be prevented.</p> <p>Test only in areas free of combustible material.</p> <p>Testing may require high voltage to be on, but only as instructed.</p> <p>Non-factory replacement parts or unauthorized equipment modifications may cause fire or injury.</p> <p>If used, the key switch bypass is intended for use only during setup operations. Production should never be done with safety interlocks disabled.</p> <p>Never use equipment intended for use in waterborne installations to spray solvent based materials.</p> |
| <p>General Use and Maintenance</p> | <p>Improper operation or maintenance may create a hazard.</p> <p>Personnel must be properly trained in the use of this equipment.</p> | <p>Personnel must be given training in accordance with the requirements of NFPA-33, Chapter 16, 1995 edition.</p> <p>Instructions and safety precautions must be read and understood prior to using this equipment.</p> <p>Comply with appropriate local, state, and national codes governing ventilation, fire protection, operation maintenance, and housekeeping. OSHA references are Sections 1910.94 and 1910.107. Also refer to NFPA-33, 1995 edition and your insurance company requirements.</p> |

| AREA Tells where hazards may occur. | HAZARD Tells what the hazard is. | SAFEGUARDS Tells how to avoid the hazard. |
|---|---|--|
| Electrical Equipment  | <p>High voltage equipment is utilized. Arcing in areas of flammable or combustible materials may occur. Personnel are exposed to high voltage during operation and maintenance.</p> <p>Protection against inadvertent arcing that may cause a fire or explosion is lost if safety circuits are disabled during operation.</p> <p>Frequent power supply shutdown indicates a problem in the system which requires correction.</p> <p>An electrical arc can ignite coating materials and cause a fire or explosion.</p> | <p>The power supply, optional remote control cabinet, and all other electrical equipment must be located outside Class I or II, Division 1 and 2 hazardous areas. Refer to NFPA No. 33, 1995 Edition.</p> <p>Turn the power supply OFF before working on the equipment.</p> <p>Test only in areas free of flammable or combustible material.</p> <p>Testing may require high voltage to be on, but only as instructed.</p> <p>Production should never be done with the safety circuits disabled.</p> <p>Before turning the high voltage on, make sure no objects are within the sparking distance.</p> |
| Spray Area / High Voltage Equipment  | <p>This is a high voltage ungrounded device that can produce electrical arcs capable of igniting coating materials.</p> | <p>Parts being sprayed must be supported on conveyors or hangers and be grounded. The resistance between the part and ground must not exceed 1 megohm. (Reference NFPA Bulletin No. 33, 1995 Edition.)</p> <p>A safe distance must be maintained between the parts being coated and the atomizer bell. A distance of at least 1 inch for each 10 KV of power supply output voltage is required at all times.</p> <p>Parts must be supported so that they will not swing and reduce the clearance specified above.</p> <p>All electrically conductive objects in the spray area, with the exception of those objects required by the process to be at high voltage, must be grounded.</p> <p>Unless specifically approved for use in hazardous locations, the power supply and other electrical equipment must not be used in Class I, Division 1 or 2 locations.</p> |

INTRODUCTION

The AdaptaFlow 5000 is a multi-channel fluid flow measurement and control system. The fluid delivery is maintained when paint supply is sufficient, regardless of paint viscosity, paint temperature, or circulation system pressure. The major components are shown in Figures 1A and 1B.

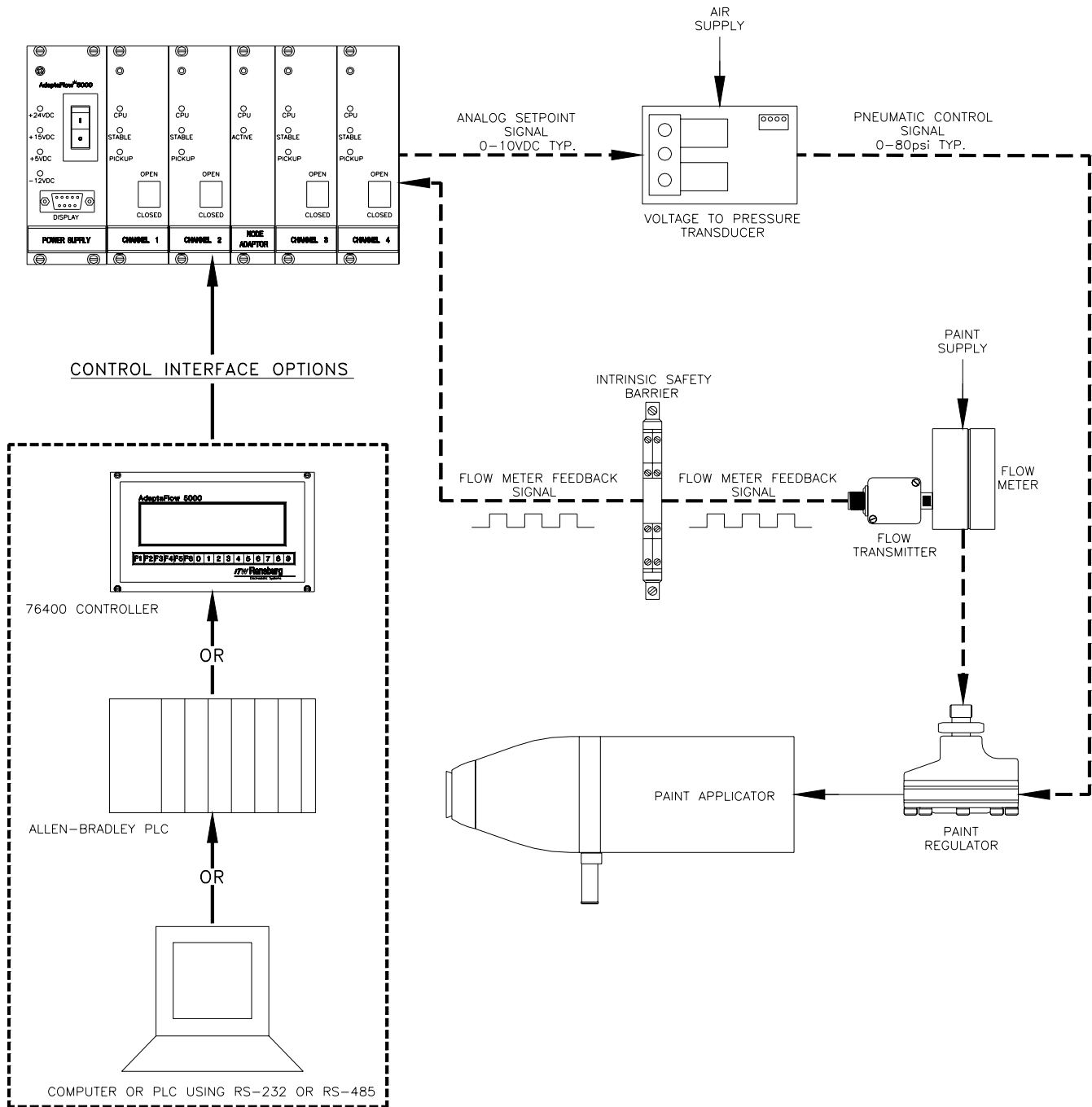

Figure 1a: Basic System Diagram - Grounded Flow Meter Applications

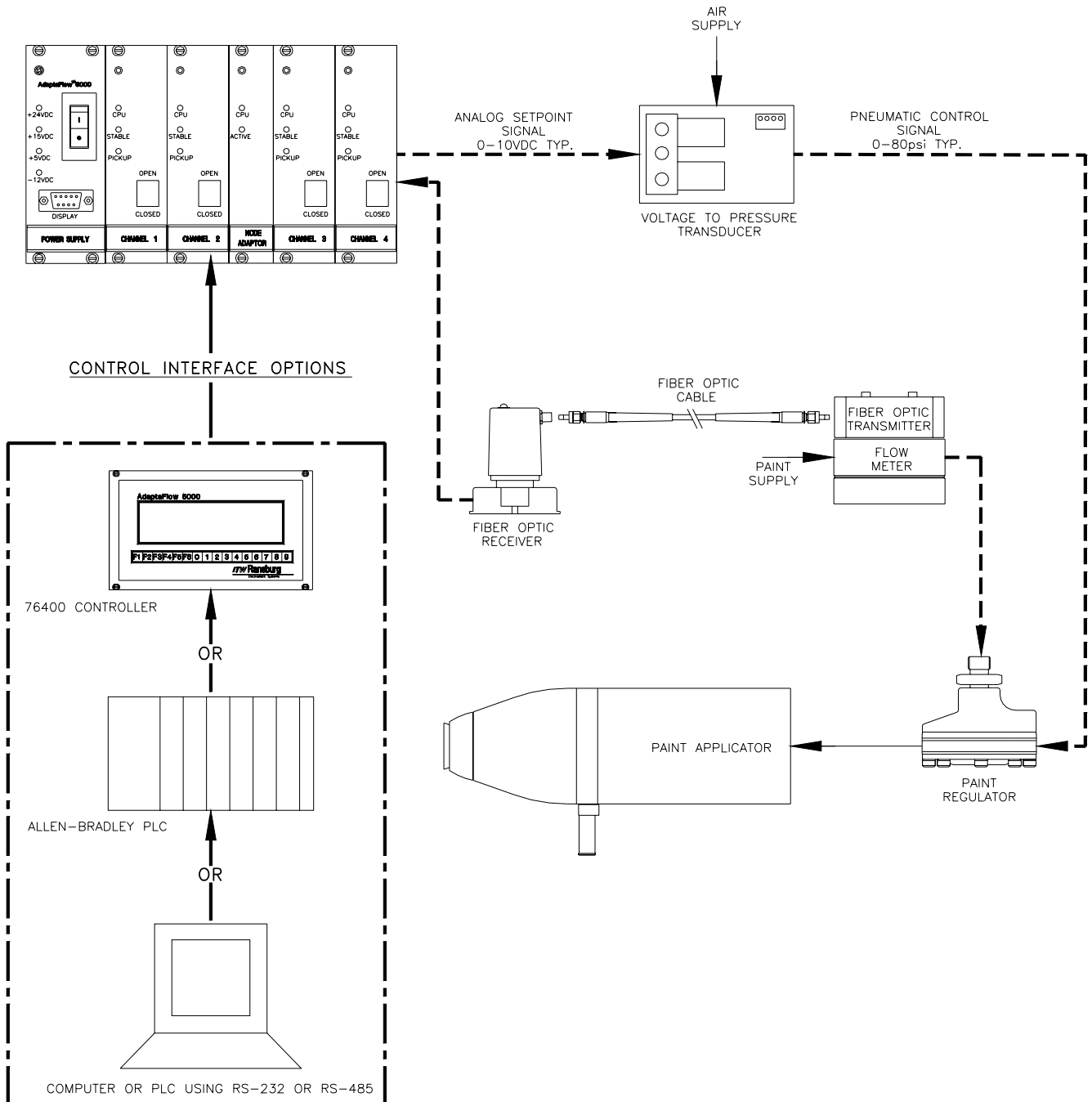

Figure 1b: Basic System Diagram - Isolated Flow Meter Applications

Up to four channels with the associated power supply card and Node Adapter Module (if required) occupies one half of a standard 19" Eurocard style rack. The AdaptaFlow Rack is mounted in standard system control panels similar to those shown in the "Appendix".

Communication and control of the AdaptaFlow Channel Modules is accomplished with one of the following:

1. Via the AdaptaFlow RS-232 or RS-485 serial communication port connected directly to a PC.
2. Via the AdaptaFlow RS-232 or RS-485 serial communication port connected to a 76400 Display/Interface Unit. The 76400 unit acts as a dedicated, programmable, user interface/display. This supplies a means to display and control fluid flow without a host PLC or PC or to locally monitor channel operation when controlled by a remote PC or PLC.
3. By using a Node Adapter connected to an Allen-Bradley PLC. The Node Adapter is covered in a separate service manual.

The 76400 is of great help during initial installation and for the operation personnel for local indication. The display unit has several screens that can be used to study the open loop responses and to view the table variable information. This unit is connected to the RS-232 port on the Card Rack Mother board or to the front of the Power Supply Module and can be plugged and unplugged during operation if used as a monitor.

In a system the control exercised over a variable such as fluid flow rate is called the *controlled output*. A *command* or *reference input* is the desired value of the controlled output. In a *closed-loop* control system, the controlled output is measured and fed back for comparison with the command input and any resulting error is used to make the controlled output correspond to the command input. The AdaptaFlow closed-loop system is illustrated in Figures 1A and 1B by the dashed lines.

Each AdaptaFlow Channel Module represents an adaptive, independent closed-loop controller for fluid control in paint systems. The feedback signal from each flow meter transmitter represents a frequency directly proportional to the fluid flow rate through the flow meter. Each Channel Module compares the instructed set point (requested flow rate) with the actual flow rate and makes corrections according to a PID (Proportional-plus-Integral-plus Differential) type control algorithm specifically developed for coating systems. Each programmable control parameter effects a different characteristic of the overall control loop. There are additional control parameters which are specific to the control of fluid in coating systems which will be discussed in later sections.

A maximum of ten points of Analog Output value versus Flow Rate are stored for each channel. There are separate tables for up to 32 colors. The controller learns new flow rate points dynamically while it paints and stores new data points in a table located in each Channel card. When an applicator is sent a flow rate setpoint, and the paint trigger is turned on, the controller finds the closest flow command setpoint from a table and immediately sends that corresponding analog output signal to the flow control transducer. Since the value is stored during actual painting, the initial setpoint for the fluid regulator pressure will be very close to the actual value needed. After a preset PID delay, the controller will switch to PID control, and adjust the analog output value based upon the flow meter feedback signal. If a new setpoint is used that is different from the previous setpoints, the flow controller will learn this setpoint, and its corresponding analog output signal, and store them in the channel card table.

Some of the programmable features for each Channel Card include:

- 4 programmable limits
- Analog output gain and offset
- Input scaling
- PID control or monitor only
- Ratio operation
- 10 point linearizer
- Cutoff frequency
- Scaling for rate indication (in engineering units)
- Scaling for totalizer (in engineering units)
- Grand total indication
- Troubleshooting and diagnostic utilities
- Color tables for up to 32 different fluids

The analog control signal generated by each channel card is typically connected to an electrical-to-pneumatic transducer, then to a pilot operated fluid regulator.

The AdaptaFlow 5000 is easily adapted to various types of closed loop systems utilizing a wide variety of input and output transducers. These high quality positive displacement gear flowmeters offered by ITW Ransburg are recommended for the following reasons:

- Insensitive to varying viscosities
- Excellent resolution
- Multiple point calibration provided with each meter
- Extremely accurate
- Rugged stainless steel and tungsten carbide design
- Available in a variety of flow capacities
- Extremely low pressure drop
- Long history of successful operation in coatings applications throughout the world

NOTES:

GENERAL DESCRIPTION

Channel Card

Each channel card has a 16 bit microprocessor with battery backed memory (RAM), U3, where all of the variables are stored including the color tables (up to 32 colors).

WARNING

- ▶ Never, under any circumstances, short together pins on U3 or any other parts on the circuit board. This can result in permanent damage to the Channel Module.

When used with the node adapter, the only connections required are power, Remote I/O Cable and an analog output to the voltage-to-pressure (V/P) converter. All of the components used are CMOS technology to guarantee high noise immunity and low power consumption. Each channel card is equipped with a hardware "watch dog" to avoid lockups due to a noisy environment.

The Input/Output pins and the frequency inputs are optically isolated. There is a 12 bit D/A converter and a high speed multiplexing chip for the analog Input/Output. All of the analog control circuits employ high impedance buffer Op-amps and diode protection to the microprocessor. The cards are connected to the card rack bus board by a 64 pin male connector.

All of the I/O signals are connected to the rear of the Bus Board. Refer to the Bus Board Installation section for details.

There are three LED indicators located on the front panel:

1. **CPU** - Is active when the microprocessor is operating normally.
2. **STABLE** - Is active when the control loop is stable. Or in other words, when there is very little or no corrective action being taken by the microprocessor.
3. **PICKUP** - Is active when the signal from the flowmeter is being received.

There is also a switch located on the front panel which places the control module in either OPEN LOOP or CLOSED LOOP mode. The OPEN LOOP mode disables PID control and can be useful for troubleshooting or setup.

Power Supply Card

The AdaptaFlow Power Supply card converts 24 VDC input to regulated DC supply voltages required by the Channel cards and the Node Adapter as well as 15 VDC for the 76400 Display/Interface Unit. The voltages produced are +15 VDC, +5 VDC and -12 VDC. There are LED's located on the front panel of the power supply card which indicate the status of each supply voltage. Also located on the front panel is the Power On/Off switch and a 76400 serial communication port. The serial communication port is also available on the Card Rack Mother Board. A switch located on the power supply card is used to select which serial input port is active.

This card is fuse protected with replaceable fuses F1 and F2 located on the circuit board. Fuse F2 is for the incoming 24 VDC and fuse F1 is for optional external flow meter power inputs (+V-PU) input on the card rack mother board.

Flow Meter

Positive displacement, gear flow meters are similar in design to a gear pump utilizing gears positioned to not come into contact with the inside housing. The gear flow meter has the advantage of high accuracy, even with low flow rates, since leakage losses around the gears are small due to the designed close tolerances.

However, principle of operation, is reversed from that of a pump; instead of the gears driving the fluid, the fluid flowing through the meter rotates the gears. This makes it possible to initiate the process with minimal starting pressure and still achieve precise measurement. These flowmeters are virtually insensitive to changes

in fluid viscosity and will function with very little pressure loss. These meters are also capable of bi-directional flow.

The speed of the gears is picked up through the meter housing by a non-obtrusive sensing device which produces an impulse for every gear tooth passing by. The resulting frequency is proportional to the instantaneous rate of flow through the meter. Pulse rates per volumetric unit of flow are relatively high which results in a very good resolution and suitable for dynamic applications.

STAND-ALONE ADAPTAFLOW 5000

The Adaptaflow 5000 stand-alone control system is dedicated solely for the purpose of controlling fluid flow. The system is made up of four major components: The control cabinet, remote operator control box, the flow meter and fluid regulator.

Control Unit

The control unit is capable of containing up to four independent control channels. Each channel within the control cabinet consists of a channel card, fiber optic receiver, transducer, automatic/manual pneumatic selector switch, manual regulator and pressure gauge. For troubleshooting or in the event of a system failure, the pneumatic switch can be placed into the manual position and regulation of the fluid performed by adjusting the manual regulator.

The 76400 user interface and display module occupies half of the 19" control rack. All programming and display functions are performed by this unit. Reference the section for the 76400 for detailed description and operation.

Also located in the stand-alone control unit is a power supply for converting 120VAC line voltage to +24VDC. The 24VDC is used by the control rack, transducers, fiber optic receivers and the remote operator box. The power ON/

OFF switch located on the front of the Adapta-Flow power supply card only controls voltage to the rack. There is no main ON/OFF switch supplied for the entire stand-alone control unit.

Remote Operator Box

The Remote Operator Box has two displays and one 5-turn potentiometer. One display indicates actual flow rate and the second display indicates the set point which is adjusted by the potentiometer.

NOTE

- ▶ The displays will read to within 5% of those displayed on the 76400 module. This is due to calibration limitations.

SPECIFICATIONS

Environmental / Physical

| | |
|---------------------------------------|--|
| Temp. Operating: | 0° to 70°C |
| CHANNEL CARD | |
| Size: | 100 x 160 mm Eurocard module, 35.2 mm wide |
| CONTROL RACK | |
| Size: | 19" (482.5 mm) x 5.2" (132.5 mm) x 7.2" (183.8 mm) Standard Eurocard Rack |
| Minimum Configuration: | 1 Power Supply Card 1 Channel Card |
| Maximum Configuration: | 1 Power Supply Card 4 Channel Cards 1 Node Adapter |
| DISPLAY/INTERFACE UNIT (76400) | |
| Size: | 8.6" x 4.8" x 2.2" |
| Panel Cutout: | 7.90" x 4.00" |
| Display: | 8 Rows x 32 Characters, Back-Lighted LCD |

Electrical

POWER SUPPLY CARD

| | |
|------------------------|---|
| Input Voltage: | 24 VDC Fused at 2 Amps |
| Output Voltage: | +24 VDC +15 VDC +5 VDC -12 VDC |

CHANNEL CARD

| | |
|-------------------------------|--|
| Control Signal Output: | 0-10 VDC |
| Signal Inputs: | See installation section for the bus board and flow meter sensors. |

SERIAL COMMUNICATION

| | |
|-----------------|---|
| RS-232C: | (J4 on bus board and front panel of power supply card) 9600 Baud, No Parity, 8 Data Bits and 1 Stop Bit (N81). Disable RS, CS, DS and CD lines. |
| RS-485: | (J4 and J16 on bus board, front panel of power supply card) |

| | |
|----------------------------------|---|
| Allen-Bradley Remote I/O: | RIO connector located on the Node Adapter Interface Board |
|----------------------------------|---|

INTRINSIC SAFETY BARRIERS

Pepperl & Fuchs Model Z779 or approved equivalent

| | |
|---------------------------------------|---------|
| Maximum Voltage: | 28 V |
| Fuse Rating: | 50 mA |
| Maximum End to End Resistance: | 327 ohm |

DISPLAY/INTERFACE UNIT (76400)

| | |
|-----------------------|---|
| Input Voltage: | 110/220 VAC, 50/60 Hz (User Selectable) or + 15 VDC from the Power Supply Card |
|-----------------------|---|

| | |
|------------------------------|---------------------------------|
| Serial Communication: | RS-232, Setup as shown above |
|------------------------------|---------------------------------|

FLOW METERS

| Model | *Range Gal/Min | Impulses Per Gallon | Impulses Per Liter | Impulses Per CC | Filtration | PSI |
|----------|----------------|---------------------|--------------------|-----------------|------------|-------|
| 73877-01 | 0.001-0.25 | 155,200 | 41,000 | 41 | 120 | 9,000 |
| 73877-08 | 0.01-0.5 | 33,311 | 8,800 | 8.8 | 120 | 9,000 |
| 73877-02 | 0.02-2.0 | 16,655 | 4,400 | 4.4 | 120 | 9,000 |
| 73877-03 | 0.1-7.0 | 6,586 | 1,740 | 1.74 | 120 | 9,000 |
| 75955-01 | 0.01-0.5 | 31,040 | 8,200 | 8.20 | 120 | 5,000 |
| 75955-02 | 0.02-2.0 | 15,900 | 4,200 | 4.20 | 120 | 5,000 |
| 75955-03 | 0.1-7.0 | 6,586 | 1,740 | 1.74 | 120 | 5,000 |
| 75955-04 | 0.01-0.5 | 31,040 | 8,200 | 8.20 | 120 | 500 |
| 75955-05 | 0.02-2.0 | 15,900 | 4,200 | 4.20 | 120 | 500 |
| 75914-10 | 0.003-1.0 | 42,500 | 11,227 | 11.23 | --- | 6,000 |
| 75914-40 | 0.1-11.0 | 13,300 | 3,513 | 3.51 | --- | 6,000 |

* For reference only. Actual flow range may vary dependent on the application. Consult your ITW Ransburg representative.

Figure 2: Flow Meters

FLOW METER SENSORS

See "Installation" Section.

INSTALLATION

- J4 SERIAL COMMUNICATION PORT
- J5 I/O FOR CHANNEL 1 AND 2
- J6 NODE ADAPTOR INTERFACE CARD
- J7 I/O FOR CHANNEL 3 AND 4
- J8 TO FLOW METER, CHANNEL 1
- J9 OUTPUT CONTROL VOLTAGE, CHANNEL 1
- J10 TO FLOW METER, CHANNEL 2
- J11 OUTPUT CONTROL VOLTAGE, CHANNEL 2
- J12 TO FLOW METER, CHANNEL 3
- J13 OUTPUT CONTROL VOLTAGE, CHANNEL 3
- J14 TO FLOW METER, CHANNEL 4
- J15 OUTPUT CONTROL VOLTAGE, CHANNEL 4
- J16 RS-485 SERIAL COMMUNICATION PORT

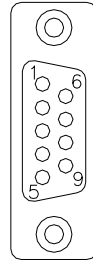

- 1 - +24VDC TO DM-3000 DISPLAY
- 2 - RS232, TX TO DISPLAY
- 3 - RS232, RX TO DISPLAY
- 4 - NOT CONNECTED
- 5 - GROUND
- 6 - RS485, RX+ TO PLC OR CPU
- 7 - RS485, TX+ TO PLC OR CPU
- 8 - RS485, RX- TO PLC OR CPU
- 9 - RS485, TX- TO PLC OR CPU

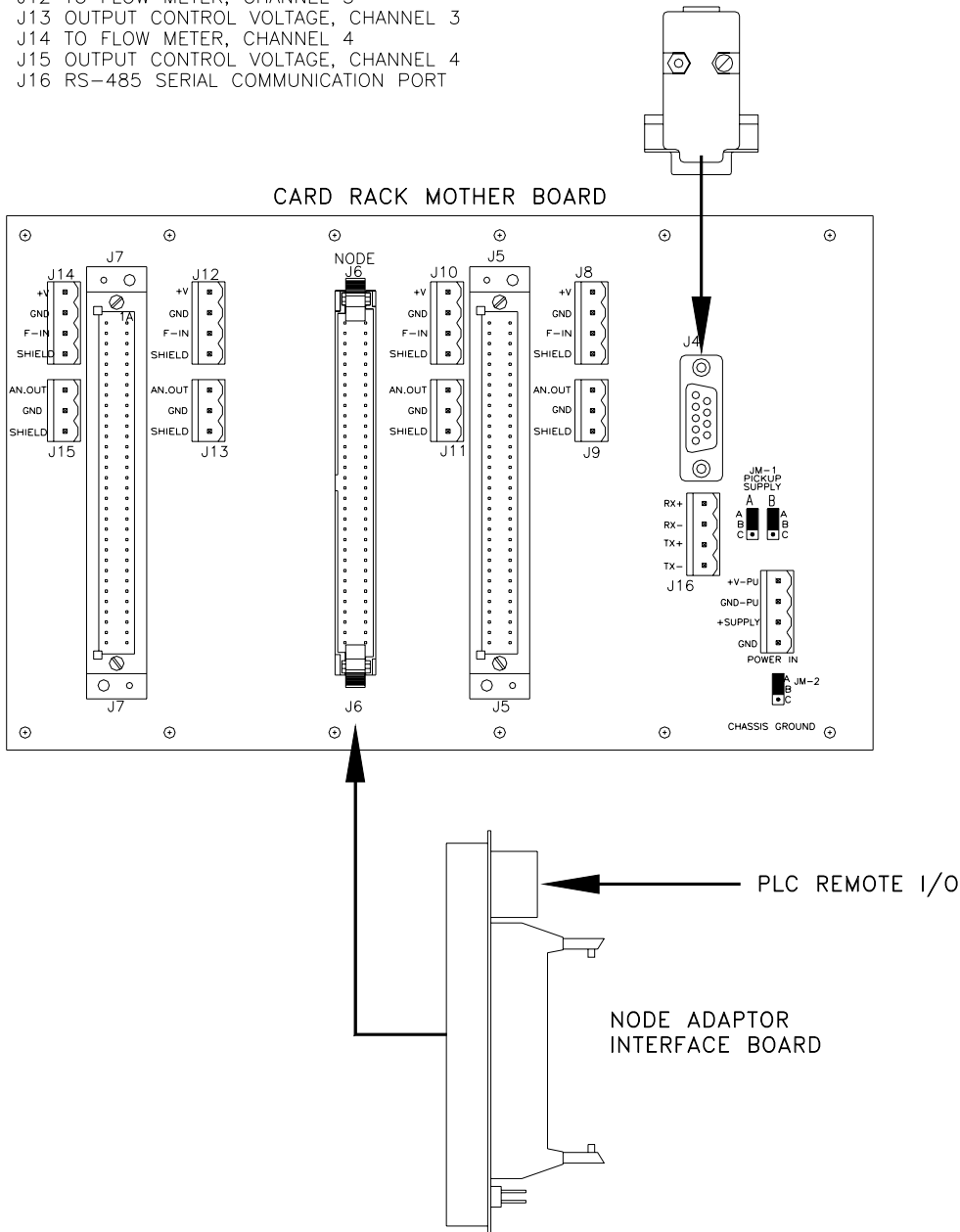

Figure 3: Bus Board

! WARNING

- ▶ The user **MUST** read and be familiar with the **SAFETY** section in this manual and the ITW Ransburg safety literature therein identified.
- ▶ This information is intended **ONLY** to indicate the general installation parameters of this product and, where applicable, its working relationship to other ITW Ransburg system components in typical use. Each installation is unique and should be directed by an ITW Ransburg representative or made from the ITW Ransburg installation drawings provided for your particular installation.

ELECTRICAL CONNECTIONS

Bus Board Connections (located on rear of rack). Also reference system schematics located in the "Appendix" section of this manual.

| BUS BOARD CONNECTIONS | | |
|---|------------------------|--|
| Connector Designation | Pin Designation | Description |
| POWER IN | +SUPPLY | 24 VDC input |
| | GND | Power supply ground |
| | +V-PU | Power supply input for flow meter pickups (when required to operate with a supply voltage other than 24VDC) |
| | GND-PU | Ground for power supply to pickups |
| J8,J10,J12,J14 (Channels 1-4 Flow Meter Connections) | +V | Supply voltage to flow meter pickup |
| | GND | Ground for both supply and signal |
| | F-IN | Frequency from pickup |
| | Shield | Shield for cable from pickup (connected to GND) |
| J9,J11,J13,J15 (Channels 1-4 Analog Control Outputs) | AN. OUT | 0-10 VDC analog output signal for control. Also serves as a user programmable analog output signal when the controller is in OPEN LOOP mode. Generally used for actual flow. |
| | GND | Ground |
| | SHIELD | Shield for control cable (connected to GND) |

Figure 4a: Bus Board Connections (Continued on page 14)

| BUS BOARD CONNECTIONS (Continued) | | | |
|--|----------------|------------------------------------|--|
| Connector Designation | Pin No. | 76061 Cable Wire Color | Description |
| J5,J7 (J5=Channel 1 & 2 I/O) (J7=Channel 3 & 4 I/O) Replace 1 & 2 with 3 & 4 for J7 | 1A | | +15 volt supply |
| | 1C | | +5 volt supply |
| | 2A | | -12 volt supply |
| | 2C | | +24 volt supply |
| | 3A* | | Frequency IN from Pickup (+) [F-IN] |
| | 3C* | | Frequency IN from Pickup (-) [GND] |
| | 4A | Black | Total reset Ch 1 [24 VDC IN] |
| | 4C | White | Total reset Ch 2 [24 VDC IN] |
| | 5A** | Red | Transparent ON Ch 1 [24 VDC IN] or limit 1 output in MONITOR MODE |
| | 5C** | Green | Transparent ON Ch 2 [24 VDC IN] or limit 1 output in MONITOR MODE |
| | 6A** | Orange | Analog hold Ch 1 [24 VDC IN] or limit 2 output in MONITOR MODE |
| | 6C** | Blue | Analog hold Ch 2 [24 VDC IN] or limit 2 output in MONITOR MODE |
| | 7A** | White/Black | Total hold Ch 1 [24 VDC IN] or limit 3 output in MONITOR MODE |
| | 7C** | Red/Black | Total hold Ch 2 [24 VDC IN] or limit 3 output in MONITOR MODE |
| | 8A** | Green/Black | Setpoint reached Ch 1 [24 VDC OUT] or limit 4 output in MONITOR MODE |
| | 8C** | Orange/Black | Setpoint reached Ch 2 [24 VDC OUT] or limit 4 output in MONITOR MODE |
| | 9A | | PID status Ch 1 [24 VDC OUT] |
| | 9C | | PID status Ch 2 [24 VDC OUT] |
| | 10A | | CPU OK Ch 1 [24 VDC OUT] |
| | 10C | | CPU OK Ch 2 [24 VDC OUT] |
| | 11A | Blue/Black | Color strobe Ch 1 [24 VDC IN] |
| | 11C | Black/White | Color strobe Ch 2 [24 VDC IN] |
| | 12A* | | Analog control out (0-10 VDC) for Channel 1 |
| | 12C | | Node bus bit 7 [node card 9C] |
| | 13A | | Node bus bit 6 [node card 10C] |
| | 13C | | Node bus bit 5 [node card 11C] |
| | 14A | | Node bus bit 4 [node card 12C] |
| | 14C | | Node bus bit 3 [node card 13C] |
| | 15A | | Node bus bit 2 [node card 14C] |
| | 15C | | Node bus bit 1 [node card 15C] |
| | 16A | | Node bus reset [node card 16A] |
| | 16C | | Node bus bit 0 [node card 16C] |
| 17A | | Node bus read [node card 17A] | |
| 17C | | Node bus write [node card 17C] | |
| 18A | | Node bus address 5 [node card 19A] | |
| 18C | | Node bus address 4 [node card 19C] | |
| 19A | | Node bus address 3 [node card 20A] | |
| 19C | | Node bus address 2 [node card 20C] | |
| 20A | | Node bus address 1 [node card 21A] | |
| 20C | | Node bus address 0 [node card 22C] | |
| 21A | Red/White | Color bit 1 Ch 1 [24 VDC IN] | |
| 21C | Green/White | Color bit 1 Ch 2 [24 VDC IN] | |

Figure 4b: Bus Board Connections (Continued on page 15)

| BUS BOARD CONNECTIONS (Continued) | | | |
|--|---|--|---|
| Connector Designation | Pin No. | 76061 Cable Wire Color | Description |
| J5,J7 (J5=Channel 1 & 2 I/O) (J7=Channel 3 & 4 I/O) Replace 1 & 2 with 3 & 4 for J7 | 22A | Blue/White | Color bit 2 Ch 1 [24 VDC IN] |
| | 22C | Black/Red | Color bit 2 Ch 2 [24 VDC IN] |
| | 23A | White/Red | Color bit 4 Ch 1 [24 VDC IN] |
| | 23C | Orange/Red | Color bit 4 Ch 2 [24 VDC IN] |
| | 24A | Blue/Red | Color bit 8 Ch 1 [24 VDC IN] |
| | 24C | Red/Green | Color bit 8 Ch 2 [24 VDC IN] |
| | 25A | Orange/Green | Color bit 16 Ch 1 [24 VDC IN] |
| | 25C | Blk/White/Red | Color bit 16 Ch 2 [24 VDC IN] |
| | 26A | Red (Twisted Pair 1) | Set point IN Ch 1 [0-10 VDC] |
| | 26C | Black (Twisted Pair 1) | Set point IN Ch 2 [0-10 VDC] |
| | 27A | White (2) | Analog output Ch 1 [0-10 VDC OUT] user programmable |
| | 27C | Black (2) | Analog output Ch 2 [0-10 VDC OUT] user programmable |
| | 28A | | Spare Ch 1 |
| | 28C | | Spare Ch 2 |
| | 29A | | Spare Ch 1 |
| | 29C | | Spare Ch 2 |
| 30A | | Serial communication | |
| 30C | | Serial communication | |
| 31A | | Serial communication | |
| 31C | | Serial communication | |
| 32A | | Ground for ALL signals except Frequency IN | |
| J16 RS-485 Serial Communication Port | RX+ RX- TX+ TX- | | Receive positive Receive negative Transmit positive Transmit negative |
| J4 Serial Communication Ports (9-pin D-sub) | 1 2 3 4 5 6 7 8 9 | | +24 VDC for 76400 display module RS-232 TX to 76400 display module RS-232 RX to 76400 display module Not connected Ground RS-485 RX+ RS-485 TX+ RS-485 RX- RS-485 TX- |
| J6 Node adapter port | | | The 75588-01 node adapter interface card plugs into this connector. This option is used if serial communication to an Allen-Bradley PLC is required. |

Figure 4c: Bus Board Connections

- * These connections are available through different connectors also located on the bus board.
- ** These connections are dual purpose depending on the mode of operation for which the controller is programmed.

I/O connections to J5 and J7 for discrete control is accomplished through a connector/cable assembly, part number 76061.

CHANNEL CARD SETUP

An 8-position DIP switch(SW1) is used to set the card channel number. The channel number is a BINARY number that is used to identify each channel card when communicating to a system PLC. The switch numbers have the following values:

| Switch Number | Value |
|---------------|----------|
| 1 | 1 |
| 2 | 2 |
| 3 | 4 |
| 4 | 8 |
| 5 | 16 |
| 6 | Not Used |
| 7 | Not Used |
| 8 | Not Used |

Figure 5: Dip Switch SW1

For example, to set the card to channel 7, switch numbers 1, 2 and 3 must be on (1+2+4=7). Switch numbers 6, 7 and 8 should always be OFF.

Dip switch 3 (SW3) settings determine whether the OPEN LOOP command voltage will originate from the flow controller or from an external voltage supplied from the SET POINT IN terminal.

Dip switch 3, positions 3 and 4 are not used.

| Dip Switch 3(SW3) | | Open Loop Function |
|-------------------|------------|--------------------|
| Position 1 | Position 2 | |
| ON | OFF | Hard Wired |
| OFF | ON | Node Adapter |

Figure 6: Dip Switch 3

Open Loop Scaling: 0-1000 in = 0-10 VDC out

* The remaining jumpers are factory set to the following positions:

| Jumper | Position | Description |
|--------|-------------|--|
| JM1 | *A-B B-C | Color strobe from node adapter active Color strobe tied high (+5V) |
| JM2 | *A-B B-C | Node adapter read/write enabled Node adapter read/write disabled |
| JM3 | *A-B B-C | Microprocessor reset by software Microprocessor reset by node adapter |
| JM4 | *A-B B-C | 8KB ram installed 32KB ram installed |
| JM5 | *A-B B-C | 32KB EPROM installed 64KB EPROM installed |

Figure 7: Remaining Jumpers

HARD WIRE CONNECTIONS FOR PID CONTROL

None of the following external signals have to be wired. However, they represent very useful features when in the PID control mode. The external signals that have an effect on PID operation are:

Transparent On

The transparent input will redirect the analog signal for flow request directly to the analog control output. It is necessary to use the transparent input if the channel is put in Open Loop simulation mode or to open a paint regulator during flushing.

Hold Analog

This input signal will hold the analog output at the last set output. The hold input is often used in flushing situations, where the controller is really supposed to be disabled.

Hold Total

Hold total will disable the totalizer. This feature is often used during flush or soft air push cycles.

Set Point Reached

This is an output that will be activated when the flow rate meets the requested set value(+/- tolerance).

PID Status

Output indicating if the channel module is in OPEN or CLOSED loop mode (24V=CLOSED, 0V=OPEN).

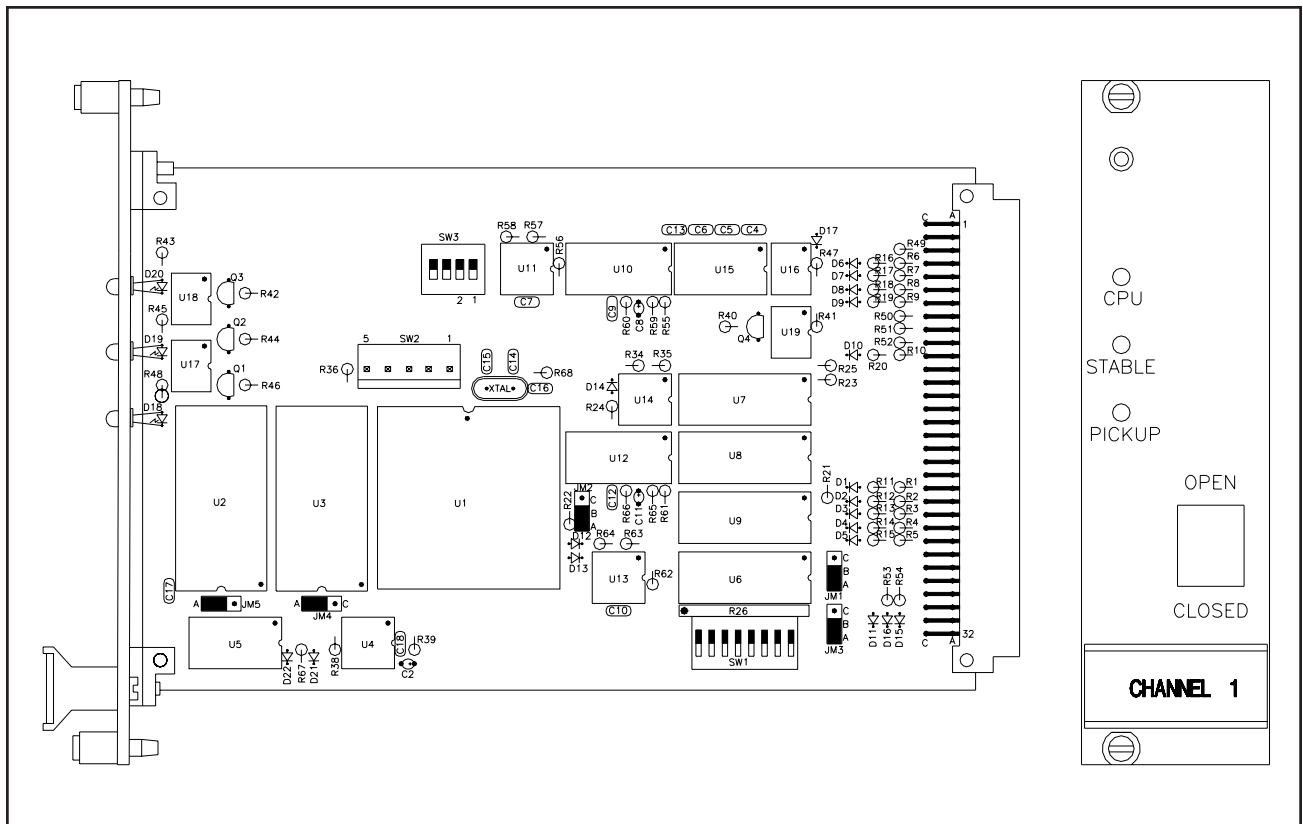

Figure 8: Channel Card

POWER SUPPLY CARD SETUP

-REFER TO FIGURE 9

SW2 Display

- **Front** - Enables serial communication to the 76400 display module.
- **Rear** - Enables serial communication to the bus board.

BUS BOARD SETUP

JM-1 Pickup Supply

See the "Installation" section for flow meter sensors.

JM-2 Ground Select

- **Pos A-B (Factory Setting)** - The power supply ground is isolated from chassis ground.
- **Pos B-C** - The power supply ground is connected to chassis ground.

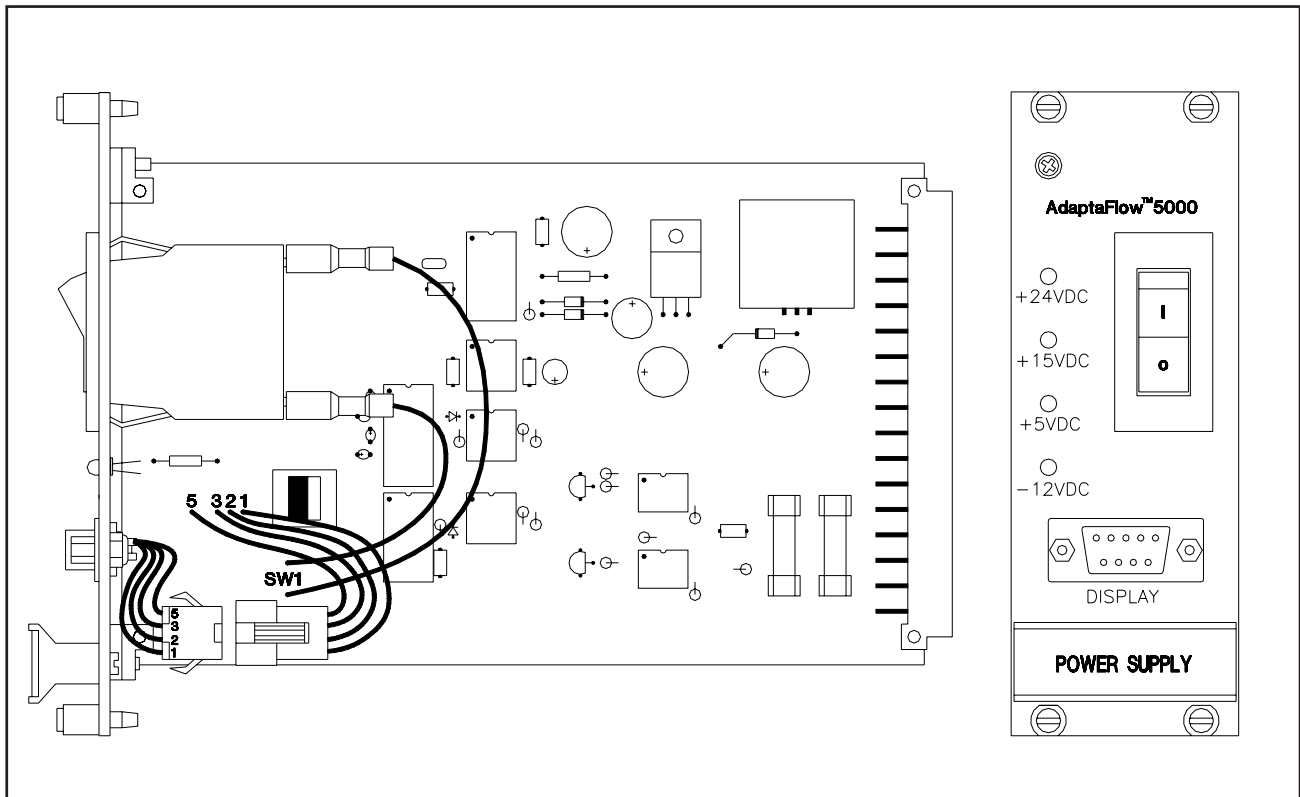



Figure 9: Power Supply Module

FLOW METER

|  CAUTION |
|---|
| <p>► Flow meters are generally located in the spray booth which is classified as a Class I, Division I, Group D location when spraying flammable materials. The installation of the flow meter must comply with the National Electrical Code and all applicable local codes which govern such practices as wiring protection, grounding, disconnects and other protection.</p> |

The standard flowmeters supplied by ITW Ransburg are positive displacement type flow transmitters and are the only units discussed in detail within this manual. These meters are volumetric positive displacement type and are normally located in the spray booth. The pickup device located on the flow meter transmits data directly to each channel card through intrinsic safety barriers or through fiber optic cables to a fiber optic transceiver. (See Figures 1a and 1b.)

Intrinsic safety barriers must be used to ensure that any electrical energy entering the spray booth is limited to a safe level. Installation of safety barriers must meet the guidelines of the manufacturer and all relevant national codes of practice. The U.S.A. and Canada both follow recommended practice ANSI/ISA RP 12.6, a part of which is incorporated in the Canadian Electrical Code, Part 1.

Fiber optic pickups are used when the flow meter must operate at high voltage, such as in isolated waterborne systems where the coating supply is conductive and elevated to high voltage. Pulses of light are transmitted through a nonconductive fiber optic cable to a receiver circuit located outside of the spray booth which then converts the light signal to an electrical signal that is connected directly to the channel card.

There are several standard flow meter models offered by ITW Ransburg as indicated in the "Specifications" and "Parts Identification" sections. All models are available in varying sizes depending on required maximum flow rates and need to be optimized for each spray system. There are more impulses per unit volume as the size of the flow meter decreases since the gears are smaller. This results in the higher resolutions needed for lower flow rates.

Size the flow meter for the application. It is important to select the correct size and type of flow meter for the application. It is recommended that you consult with ITW Ransburg before purchasing a meter.

| Flow Meter Model | Sensor Options | Applications / Features |
|------------------|-------------------------|---|
| 73877 | 73864 76015 76016 | Applications that require bi-directional flow sensing. |
| 75955-01,02,03 | 76018 75956 | Standard for most applications. Body is 303 SS, gears are 321 SS. |
| 75955-04,05 | 76018 76019 75956 | Waterborne coatings. Tin electro-coated gears for abrasion resistance. Redesigned shafts, flow pathways and a new gasket seal which results in lower pressure drops. Small size. |
| 75914 | 76016 | 1:100 turn down ratio, helical surface hardened rotor design. For high viscosity or abrasive materials. Easy to clean. Very low pressure drop. |

Figure 10: Flow Meter Selection Guidelines

Replacement or spare parts are available for all of the flow meters. Contact your ITW Ransburg representative for availability and ordering information.

| Flow Meter Sensor | Description | Specifications | Connections |
|-------------------|-------------------------|---|--|
| 76015 | Hall Sensor | Supply Voltage: 7-29 VDC Current: <8 ma Output Signal: 3 KHz Max. | Pin 1: Supply Voltage Pin 2: Output Signal Pin 3: Common Pin 4: Not Used Pin 5: Not Used |
| 76018 | Carrier Frequency | Supply Voltage: 10-30 VDC Output: 1.5 V | Pin A: Supply Voltage Pin B: Common Pin C: Output Signal |
| 75956 | Fiber Optic Transmitter | Supply Voltage: Battery Output: IR Light | Fiber optic cable. Connects to 76017, fiber optic receiver (see below). |
| 76019 | Fiber Optic Transmitter | Supply Voltage: Battery Output: IR Light | Fiber optic cable. Connects to 76017, fiber optic receiver (see below). |
| 73864 | Hall Sensor | Supply Voltage: 8-24 VDC | Pin A: Supply Voltage Pin B: Common Pin C: Output Signal |
| 76016 | Hall Sensor | Supply Voltage: 7-29 VDC Current: <4 ma Output Frequency: 3 KHz Max. Output Voltage: Jumper Selectable (See below) | See below |

Figure 11: Flow Meter Sensor Options

Flow meter pickup connections to the AdaptaFlow control unit are to J8, J10, J12 and J14.

| Designation | Description |
|-------------|---|
| +V | * Supply voltage to pickup (24 VDC or 15 VDC) |
| GND | Ground |
| F-IN | Signal in from pickup (frequency) |
| SHIELD | Cable shield from pickup (connected to GND) |

Figure 12: Flow Meter Connections

* The JM-1 Jumpers (A and B), located on the bus board, controls the source for the pickup supply voltage.

| Positions | | Description |
|-----------|----------|--|
| JM-1 (A) | JM-1 (B) | |
| A-B | A-B | Separate supply for pickups and rack |
| *B-C | *B-C | Common supply for pickups and rack |
| B-C | A-B | Common ground and different supply voltage |

*Factory setting.

Figure 13: Flow Meter Power Supply Selection

Some flow meter pickups may require a supply voltage other than the +15VDC and +24VDC supplied from the AdaptaFlow system. This may be due to the type of pickup used, the location of the pickup wiring terminations, or the type of intrinsic safety barriers used.

FLOWMETER SENSORS

General

When dealing with low voltage/power signals from pickups or transmitters, it is important to use a shielded cable between the transmitter and signal processing unit. A shielded cable will keep most of the electro-magnetic interference (EMI) from entering the signal cable and disrupting the signal before it can be processed. A 20-22 AWG, Plenum Teflon® coated control cable, similar to a Beldon #88723, is recommended.

When connecting instrumentation without an intrinsic safety barrier, connect the shield together with the wire for the signal ground, to the **Instrument Ground** terminal. **NEVER CONNECT THE SHIELD TO GROUND AT BOTH ENDS.** Also reference Figure 57 in the "Appendix" section of this manual.

Guidelines

1. To prevent extraneous signal noise, ensure that a clean, central ground is established for both the flowmeter and sensor.
2. Where possible, keep the signal cable at least 1 foot from any cable handling 110 VAC. If several signal cables are used, consider using metal conduit tubing for the signal cables for extra protection from external noise and EMI. Ground the conduit at one end to a water pipe, structural steel, or other.
3. If used in a location where there are motor starters and other controls using relays, be sure there are diodes mounted across coils for DC relays and an R-C network for AC relays. This will dampen EMI from the relays when they operate.
4. Never pull cards or modules out of their sockets or connectors with power on.

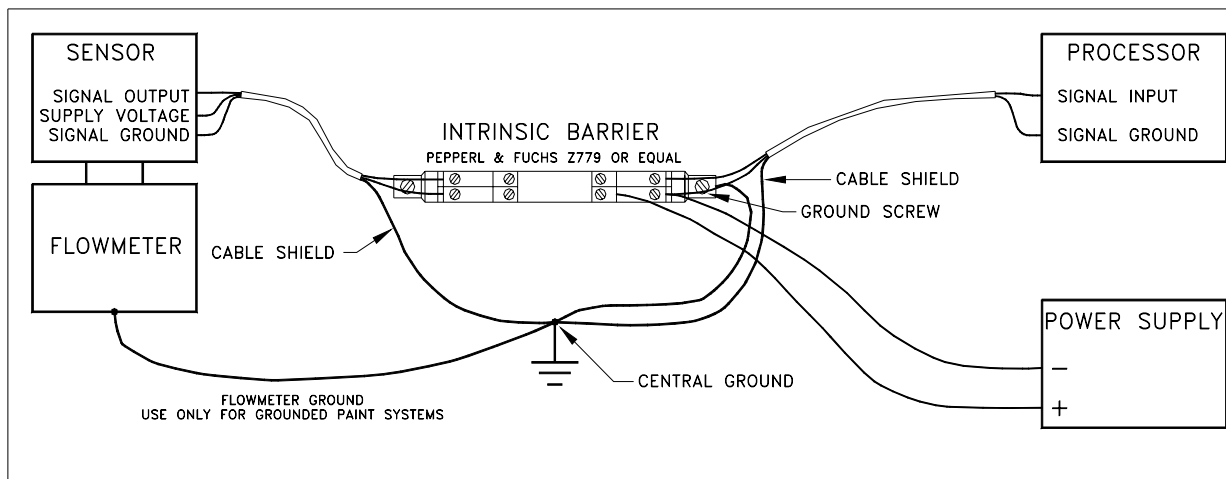

Figure 14: Intrinsic Wiring

76015 Sensor Installation

| Sensor Pin Number | Value |
|-------------------|-------------------------------|
| 1 | Supply Voltage (+8 to 28 VDC) |
| 2 | Output (Frequency) |
| 3 | Ground |
| 4 | Not Used |
| 5 | Not Used |

Supply Current: < 8 ma

Output Pulse High: Supply Voltage -1.2 V

Output Pulse Low: < .7 V

Maximum Frequency: 3 KHZ

Figure 15: 76015 Sensor Connections

Installation: Turn the sensor into the flow meter until hand tight. Back off 1/4 turn and tighten the lock nut.

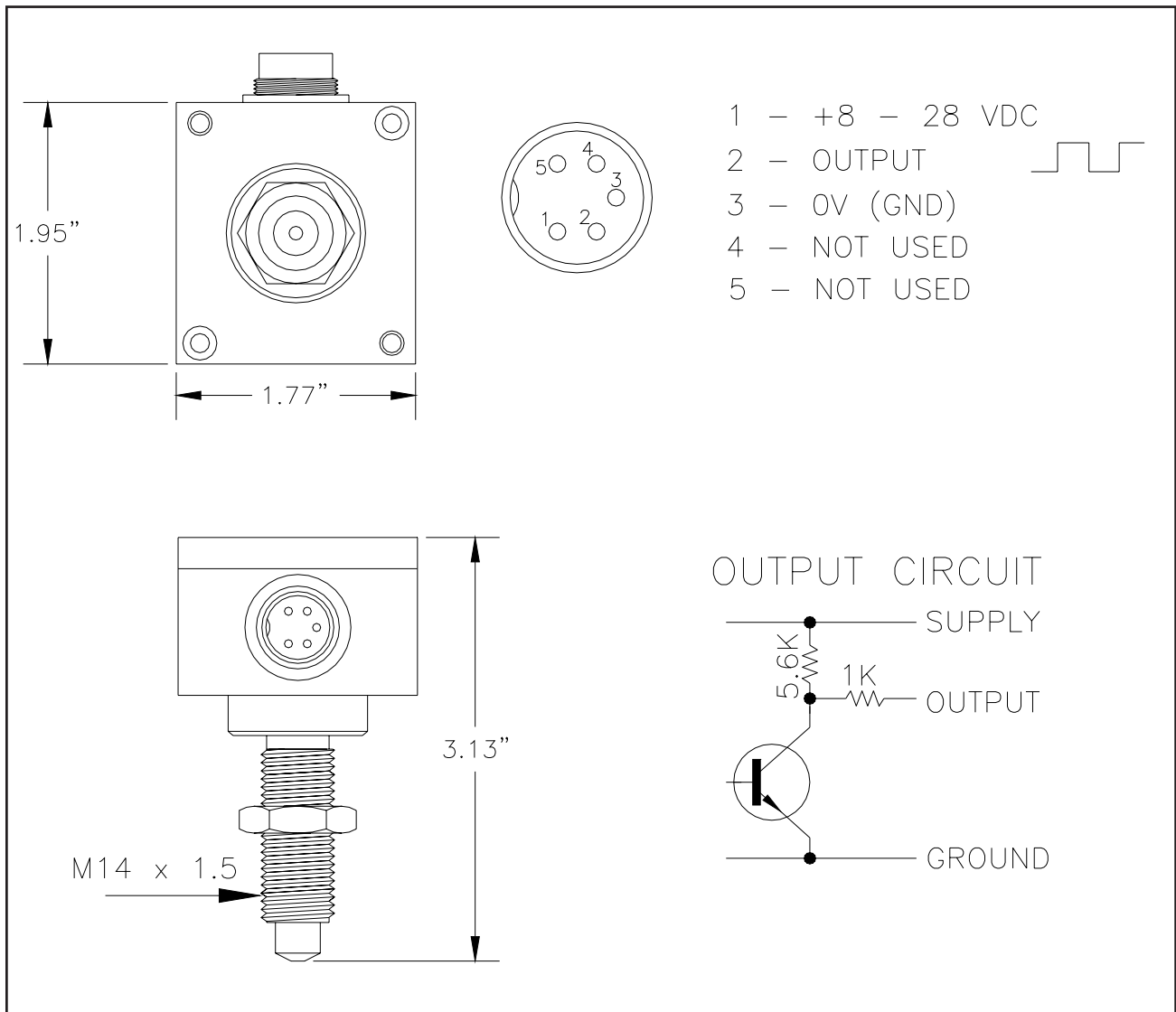

Figure 16: 76015 Sensor

76016 Sensor Installation

| Version | J3 | J4 | J5 | J6 | Terminal |
|--------------------|-----|-----|-----|-----|----------|
| 2-Wire | Off | On | Off | Off | 1, 2 |
| 3-Wire Active NPN | On | Off | Off | On | 1, 2, 3 |
| 3-Wire Active PNP | On | Off | On | Off | 1, 2, 3 |
| 3-Wire Passive NPN | Off | Off | Off | On | 1, 2, 3 |

Figure 17: 76016 Sensor Jumper Settings

2-Wire

High: $I(\text{high}) > 2.2 \text{ ma}$

Low: $I(\text{low}) < 1.4 \text{ ma}$

3-Wire Active Output NPN

High: $V(\text{high}) > V(\text{supply}) - 0.6V - (2.6K \text{ ohm} * I_{\text{out}})$

Low: $I(\text{low}) > 0.6V + (1.3K \text{ ohm} * I_{\text{out}})$

3-Wire Passive Output NPN (Open Collector)

High: $V(\text{high}) = V(\text{supply})$

Low: $V(\text{low}) < 0.6V + (1.3K \text{ ohm} * I_{\text{out}})$

3-Wire Active Output PNP

High: $V(\text{high}) > V(\text{supply}) - 0.6V - (150 \text{ ohm} * I_{\text{out}})$

Low: $V(\text{low}) = \text{Cutoff}$

3-Wire Passive Output NPN (Open Collector)

High: $V(\text{high}) > V(\text{supply}) - 0.6V - (150 \text{ ohm} * I_{\text{out}})$

Low: $V(\text{low}) = \text{Cutoff}$

$I_{\text{max.}} = 60 \text{ ma}$, $P_{\text{max ON}}$, $R_s = 1W$, $R_s = 150 \text{ ohm}$

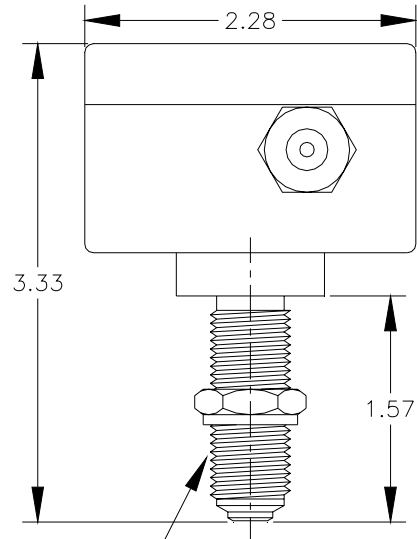
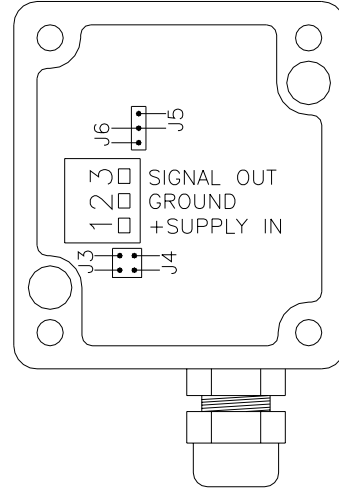
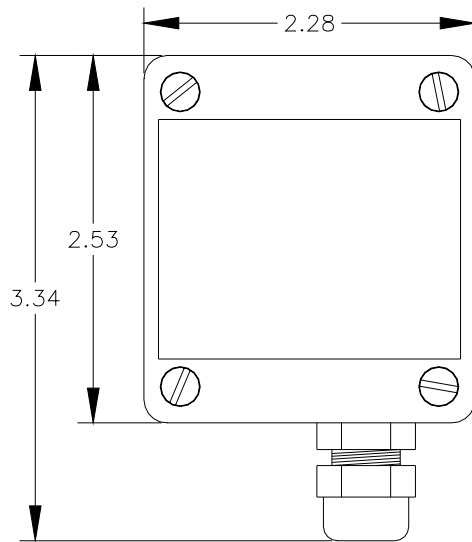

M14x1.5

HIGH: $I_{high} > 2.2\text{mA}$
LOW: $I_{low} < 1.4\text{mA}$

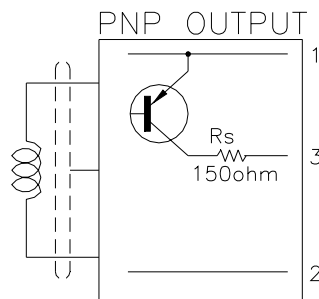
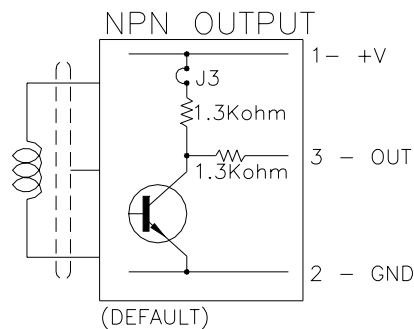

Figure 18: 76016 Sensor

76018 Sensor Installation

The 76018 sensor is a carrier frequency sensor which means there is no permanent magnet in the pickup and therefore no drag placed on the flow meter gears. The output signal is a square wave, voltage pulse of approximately the supply voltage minus 1.5V. The frequency is proportional to the meter flow rate. The 76018-01 has a sourcing open collector PNP transistor output. The 76018-02 has a sinking type NPN transistor output.

- Supply Voltage:** 10-30 VDC
- Supply Current:** 9 ma at 15V, Max. 18 ma
- Minimum Frequency:** 0.5 HZ
- Maximum Frequency:** 2 KHZ
- Signal Output High:** Supply Voltage -1.4 V
- (120 x Iout)
- Signal Output Low:** 0 V

Ensure that the flowmeter sensor cavity is free of dirt prior to installation. Screw the 76018 sensor into the flowmeter until the sensor nose contacts the bottom of the cavity. Leave no air gap remaining. The sensor may be screwed in by hand and seated by using a light 9/16" wrench on the sensor keyway.

| ⚠ CAUTION | |
|------------------|---|
| ▶ | Do not exceed 7 newton-meters force to seat the sensor. This is equivalent to hand tight. Excessive force may crush the sensor nose and damage the flowmeter. |

| Sensor Pin Number | Description |
|-------------------|-------------------------------|
| A | Supply Voltage (+8 to 28 VDC) |
| B | Ground |
| C | Output (Frequency) |

Figure 19: 76018 Sensor Connections

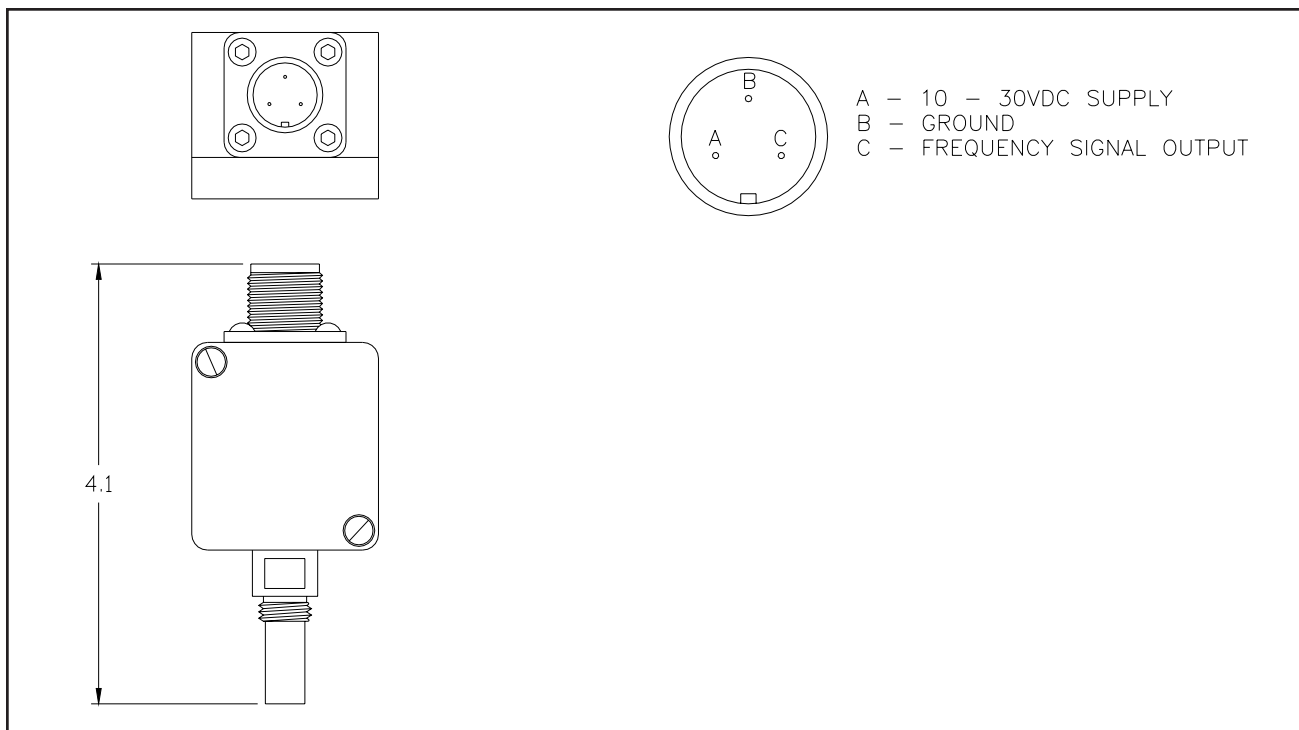

Figure 20: 76018 Sensor

Fiber Optic Sensor Options

Fiber optic sensors allow the incorporation of flow meters into fully charged electrostatic paint systems. The flow meter is allowed to be charged to the same high voltage as the paint applicators (typically 60-100KV). There are two fiber optic sensor systems used depending on the flow meter. 76020-01 through -04 include the 75956 transmitter and 76020-05 through -08 include the 76019 transmitter. Both of these systems use the same 76017 fiber optic receiver.

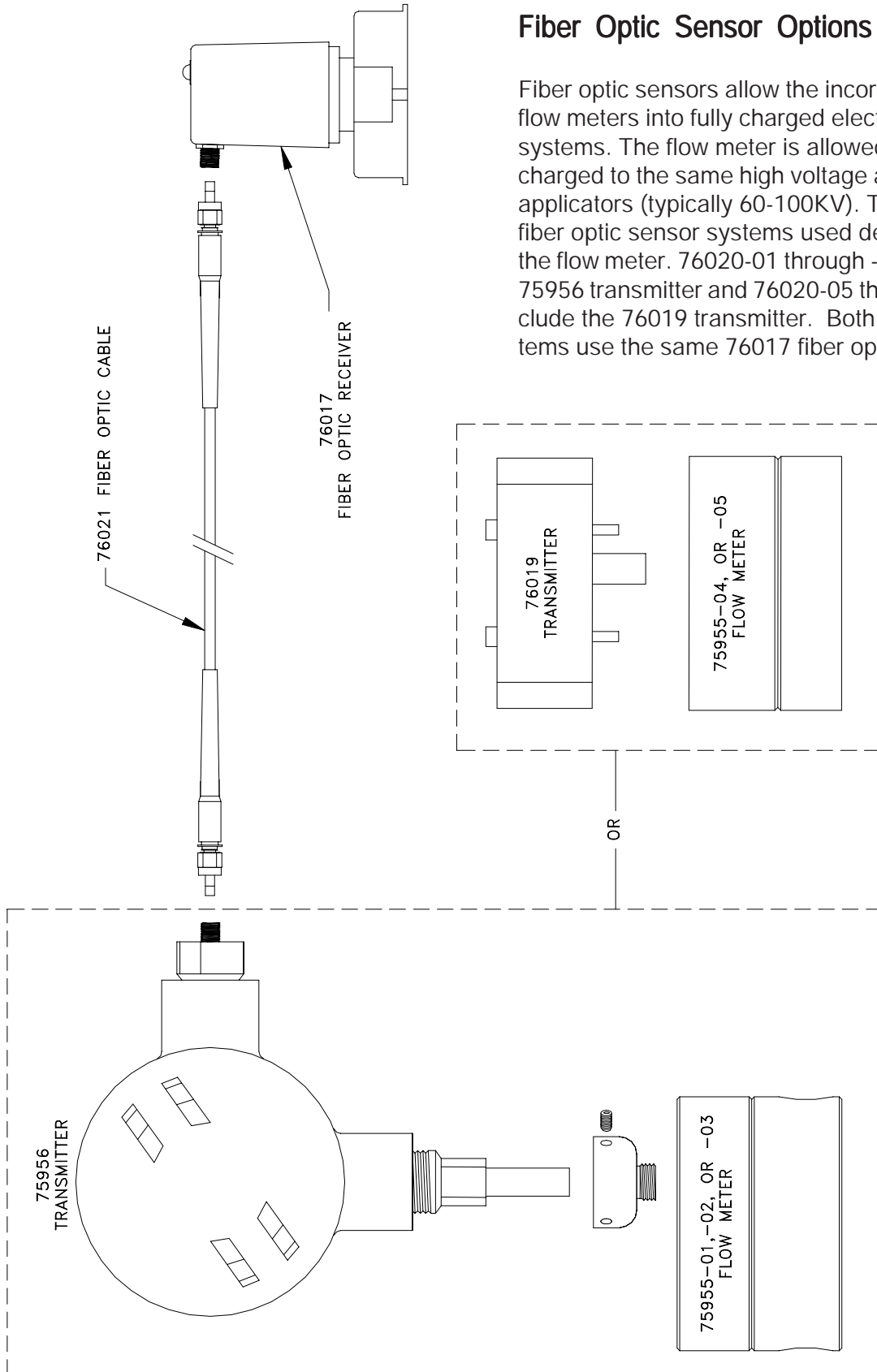

Figure 21: Fiber Optic Pickup System

75956 Fiber Optic Transmitter

The 75956 transmitter consists of a reluctance type pickup with the fiber optic transmitter located in an explosion proof housing. To install the 75956 transmitter:

1. Remove the swivel base from the 75956.
2. Insert and tighten the swivel base into the flow meter.
3. Insert the 75956 transmitter into the flow meter.
4. Tighten the swivel base set screw with a 5/16" hex key.

76019 Fiber Optic Transmitter

The 76019 fiber optic transmitter is an intrinsic device approved by UL for Class 1, Groups A, B, C & D locations. Both of the fiber optic transmitters incorporate a battery with a life expectancy between 5 and 10 years depending on usage.

NOTE

- ▶ Before installing the fiber optic cable, inspect the glass lens inside the cable fitting on the transmitter to ensure that it is clean.

Fiber Optic Cable

The fiber optic cable has a heavy-duty polyethylene outer jacket with a PVC inner jacket and two layers of braided Kevlar yarn for extra strength. The fiber optic cables are supplied as assemblies.

⚠ CAUTION

- ▶ The cable end connectors are installed with special tools. Therefore, **NEVER** cut the cable.

If the cable needs to pass through walls or panels, a clearance hole with a minimum diameter of 3/8" is required. The core of the cable is glass, therefore any sharp bends **MUST** be avoided. The **MINIMUM** bend radius should not be less than 9". Always be careful not to damage the ends of the cable. During installation the protective caps **MUST** be kept on at all times.

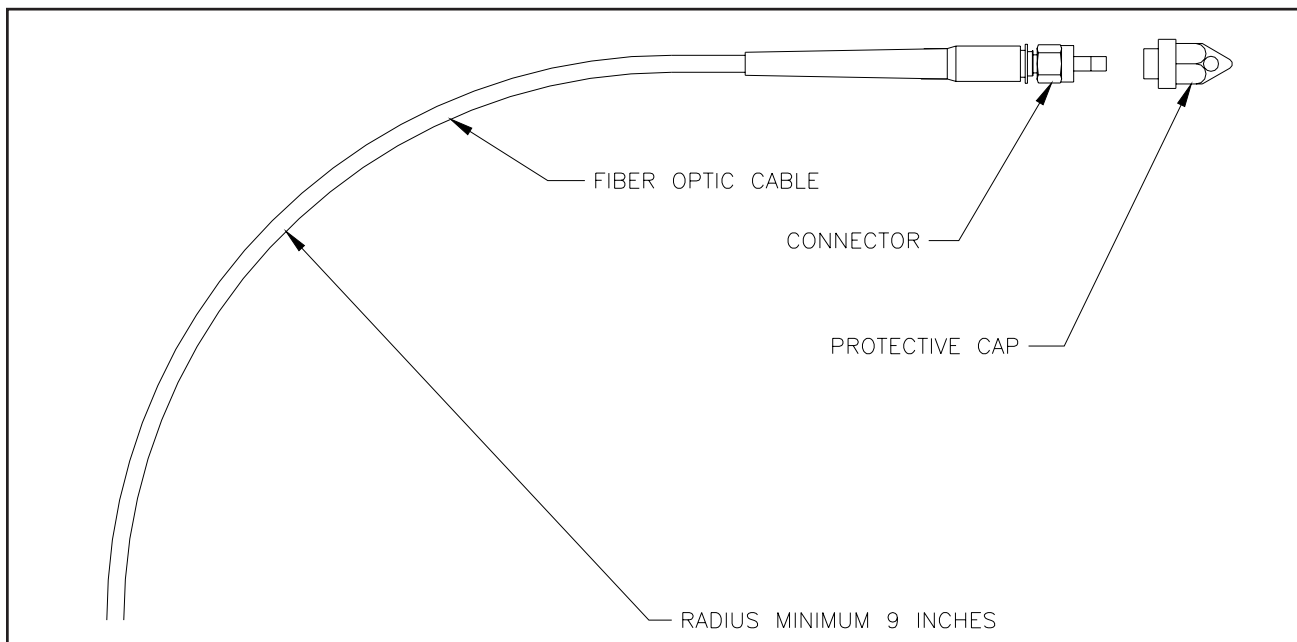

Figure 22: Fiber Optic Cable

76019 Fiber Optic Receiver

A red LED is located on the top of the 76019 which will blink when a frequency signal is detected from the fiber optic cable. It is recommended that the receiver be installed to allow easy observation of the LED. The output of the receiver is a square wave frequency proportional to the flow through the flow meter.

Installation Note: To reduce the chance of noise causing the receiver to emit false signals, it is recommended that terminal 8 be connected to either panel (earth) ground or to terminal 2 on the 76019. Panel ground is the preferred choice of connection.

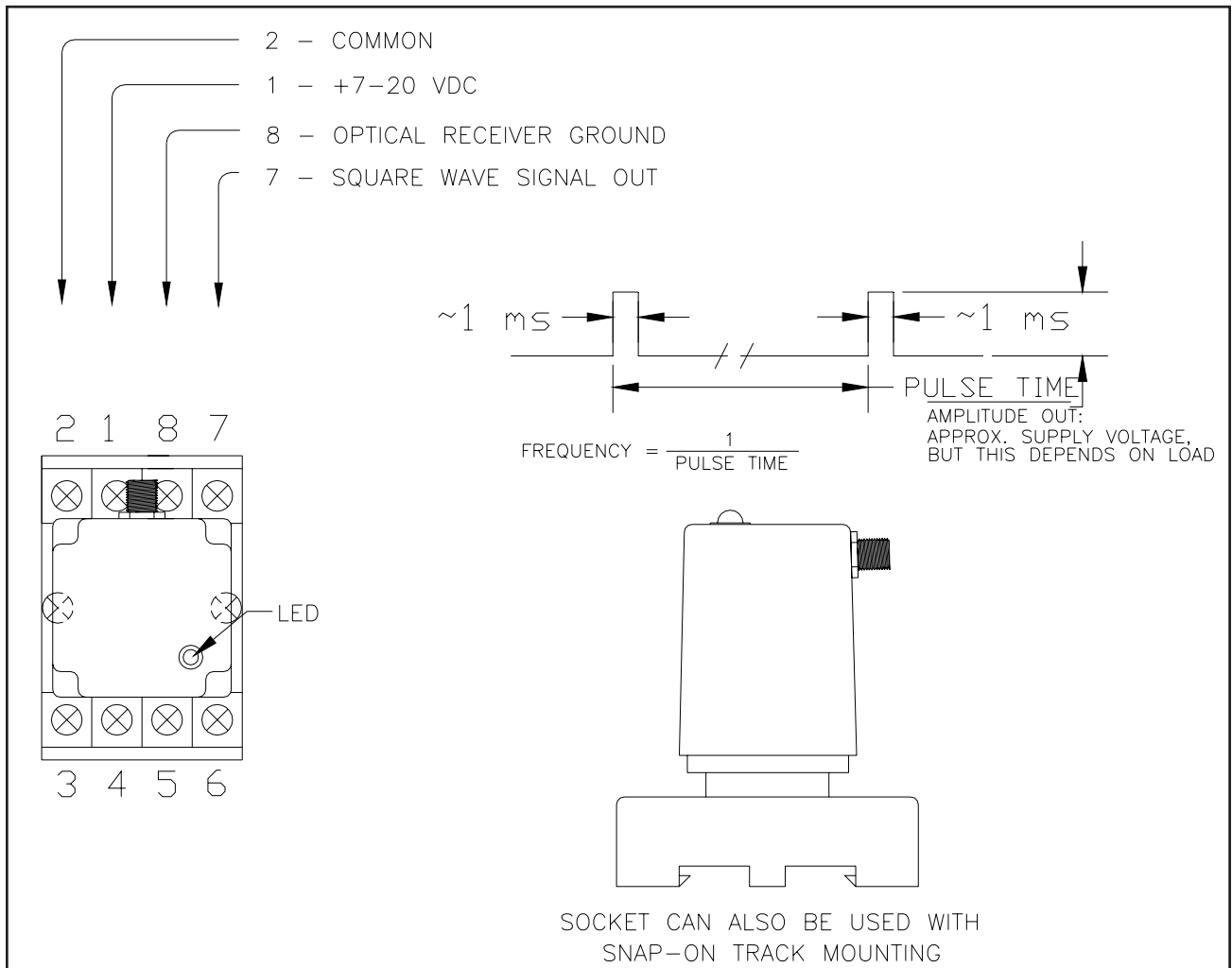



Figure 23: 76019 Fiber Optic Receiver

76400 DISPLAY / CONTROL UNIT

In most cases, the 76400 can be installed using only the 9 pin D-Sub power/communication cable provided with the unit. The cable can be connected to the front of the power supply card or to the rear of the mother board. The standard cable length is 15ft. and the maximum cable length is 50ft. Longer lengths are not recommended, but can be provided. The power/communication cable should be routed as far as possible from electric motors, servos and other sources of noise sources. This will avoid communication errors and improve performance.

The 76400 is normally powered via the cable from the AdaptaFlow 5000, but can be powered separately by connecting either 110/220 VAC to the 3 pin power connector. The unit is normally set for 110 VAC, but can be set for 220 VAC by moving jumper 1 inside the 76400 from position A and C to position B only. Position B is the center position on the 3 position jumper header located near the transformer.

Once powered by 110/220 VAC, the 76400 still requires a communication cable with the pin layout shown in Figure 24. The 15 VDC on Pin 1 would no longer be required.

|  CAUTION | |
|---|--|
| <p>► The serial communication cable which connects the AdaptaFlow 5000 with the 76400, carries +15VDC. There is danger of damage if the +15VDC on Pin 1 is connected to a host computer or PLC. Only use the cable provided for its intended use.</p> | |

| From AdaptaFlow 5000 | To 76400 | Description |
|----------------------|----------|----------------------|
| 1 | 1 | +15 VDC Power |
| 2 | 3 | RS-232 Data Transmit |
| 3 | 2 | RS-232 Data Receive |
| 5, *Cable Shield | 5 | Ground |

*Note: Only ground the cable shield at one end.

Figure 24: Power/Communication Cable

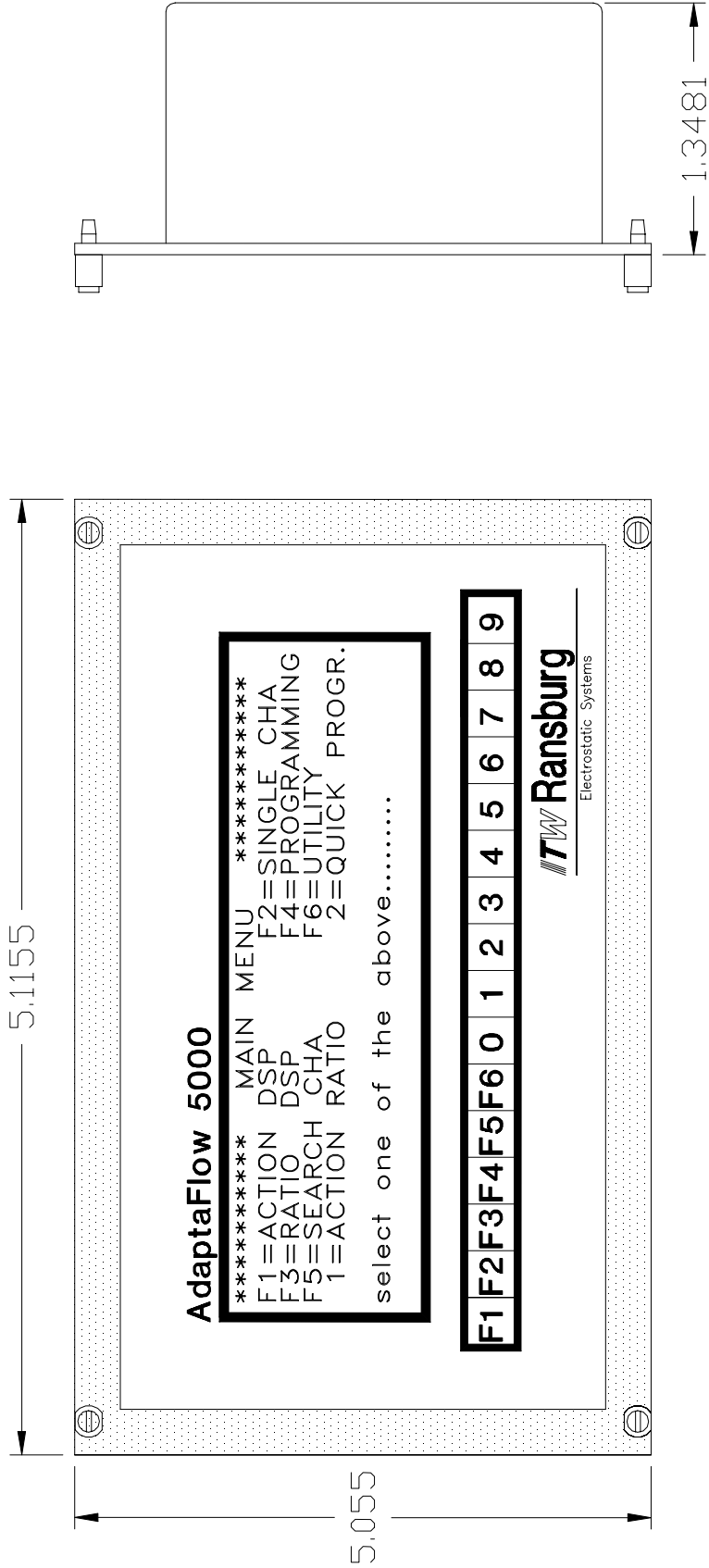

Figure 25: 76400 Unit

STAND-ALONE CONTROL UNIT

The installation of the AdaptaFlow 5000 stand-alone unit is fairly straight forward, with only five basic steps.

1. **Fluid Hook Up:**

The flow upstream of the fluid regulator should be the same as the flow downstream of the fluid regulator, so the flow meter could be placed on either side. For consistency, the flow meter is placed on the downstream side of the fluid regulator. The flow meter and the fluid regulator should be placed as close to each other and as close to the atomizer as possible for the best control. Avoid using elbows or tight bends whenever possible, as these will induce turbulence into the fluid flow.

NOTE

- ▶ The fluid must be regulated prior to the DR-1 regulator. The inlet pressure to the DR-1 must not exceed 100 psi.

2. **Fiber Optic Cables:**

The fiber optic cables are attached from the transmitter, on the flowmeter, to the receiver located inside the AdaptaFlow 5000 control unit. Caution should be used when handling fiber optic cables, since they are glass fiber cables and are somewhat fragile. Simply attach the cables to the proper channel receiver.

3. **Remote Setpoint/Display Units:**

The remote units can be located anywhere in a NONHAZARDOUS area. There will be one remote unit for each channel. The units are the primary method of entering the fluid flow rate set point, therefore they should be easily accessible. A shielded cable is used to connect the remote boxes to the AdaptaFlow 5000 control unit. The cable comes in a standard length of 40 ft. Both ends of the cable are identical, so either end can be attached to either the remote unit or the control unit.

4. **A/C Hook Up (120 VAC):**

The AdaptaFlow 5000 is setup for 120 VAC only. Although the unit is shipped with a supply cord, ITW Ransburg strongly advises the use of conduit to a disconnect box located as close as possible to the control unit.

5. **Pneumatics:**

Main air IN should be factory air, dried and filtered. The air line from the control unit to the fluid regulator should have as small of an I.D. as possible. A large I.D. air line may cause the air inside the line to compress and uncompress making the system more unstable, this is true especially in long runs of tubing.

The hold signal to each channel should come from the paint trigger signal. When paint is triggered OFF, the hold signal forces the corresponding channel card to freeze the output control signal. This is important for the following reasons:

1. While in this dormant state, the AdaptaFlow 5000 will continue to output the same air signal as when the HOLD switch was turned on. This will allow the AdaptaFlow 5000 to more easily pick up control when the paint is triggered back on.
2. The AdaptaFlow 5000 creates a table of values that allows it to jump to a specific output depending on the setpoint. When a new setpoint is entered, the AdaptaFlow 5000 looks at this table and jumps to the matching output. By doing this, the system becomes stable much quicker. Without the HOLD signal, during a flush sequence, the AdaptaFlow 5000 will try to control the solvent and at the same time try to update the tables. If the tables are updated during a flush cycle, they will be incorrect the next time the paint is loaded and will not function properly. In this situation, the system might stay unstable for a rather lengthy period of time.

3. If the fluid is triggered off without the HOLD signal, the AdaptaFlow 5000 interprets this as a decrease in fluid flow. Since the fluid flow is decreasing, the AdaptaFlow 5000 will try to compensate by increasing the output to maximum. When the fluid is again triggered on, the flow rate will be too high, forcing the AdaptaFlow 5000 to drop the output signal very low. This reaction will start the system into a large oscillation, which could take some time to stabilize.

NOTES:

OPERATION

The AdaptaFlow 5000 has two primary operating modes, Monitor Mode (open loop) and PID Control Mode (closed loop). The linearizer operations are additional features that can be used in either Monitor or PID Modes that further define the operation of the AdaptaFlow 5000.

MONITOR MODE

Monitor Mode is used for applications where it is important only to monitor flow rates and totals. This mode also provides programmable analog and limit outputs. The programmable limit values can activate relay contacts either ON or OFF (N.C. or N.O. operation). The 0-10 volt analog outputs can be scaled to the flow rate or the total which can be recorded in strip chart form, as a digital recording, or sent to a PLC via the serial communication link.

If analog outputs or limits are to be used in the monitor mode, the following additional variables need to be programmed:

Analog Output Gain

Scales the voltage output signal.

Analog Out Pointer

Address for the variable that should be expressed at the analog output.

Analog Out Offset

A programmed current or voltage value output that will correspond to a zero input frequency.

Limits

Trip point values can be programmed for Total or Rate limits which when exceeded will activate the selected Limit.

Reference the "76400 Display/Control Unit" section of this manual for details on the above.

PID CONTROL MODE

The following is an explanation of a PID (Proportional plus Integral plus Differential) or three mode, control system and some general guidelines for achieving stable fluid control.

It is known that the system response can be altered by changing any variable within the system such as paint viscosity, paint regulators, pilot line lengths, etc.

There are basically two areas of concern with regard to a flow control system and changing parameters therein on-transitional or steady-state flow and transitional or step response resulting from a requested change of desired flow rate or from a sudden change in load. The integral portion of the PID effects the steady-state gain whereas the derivative effects mostly the step response. The proportional relates to the overall gain and hence effects both the steady-state and step responses. There is more detailed information about each of the three PID components and the other variables required for PID control listed under "Variable Definitions" in the "Program Control" section of this manual.

LINEARIZER OPERATION

The AdaptaFlow 5000 features a fully programmable 10 point linearizer. The linearizer corrects for errors over the flow transmitter's indicating range using the calibration data supplied for that particular transmitter. The linearizer can be used in any operating mode; Monitor, PID, or Ratio. The corrections can be based on either the frequency input A, B, or both A and B.

In the programming screen of the 76400, if the programmer selects mode 3 = LINEARIZER, the 10 error points and their associated error percentages can be programmed. The linearizer can then be activated and directed to the correct input under the GENERAL A variables. The commands for operation are as follows:

| | |
|----------------|---------------------|
| LINEARIZER = 0 | OFF |
| LINEARIZER = 1 | FREQUENCY INPUT A |
| LINEARIZER = 2 | FREQUENCY INPUT B |
| LINEARIZER = 3 | BOTH A AND B INPUTS |

NOTE

- ▶ In the majority of cases, it is unnecessary to program the linearizer. If using a positive displacement type flow meter for the right application, the errors are usually less than .5% and are therefore negligible. If the linearizer is programmed to correct for less than 1%, there is little chance of improving the system performance.

NOTES:

PROGRAM CONTROL

COMMUNICATION PROTOCOL

The following describes the serial protocol and is used for communication to each channel control card. This format is extremely convenient since it returns an ascii string already in the correct engineering units and in some cases with the engineering units attached. Data can be requested from the AdaptaFlow 5000 in either engineering units or normalized (Hertz/Pulses). The protocol is as follows:

Reading

#XXVYYY/ZZcr

- # Pound sign is the indication that ASCII form is to be used.
- XX Channel number 00 to FF in ASCII. This is in hex and must represent capital letters.
- V E will return requested data in engineering units. N will return normalized data.
- YYY Three digit ASCII command number 100...999. Not all numbers are used.
- /ZZ Specifies color table number. This only needs to be included when using the color tables. The default is for color 0.
- CR Carriage return character (decimal 13 or hex OD). No check sum is used.

Writing

#XXVYYY/ZZ/bbb.bcr

- # Pound sign indicates that ASCII form is to be used.
- XX Channel number 01...FF. This is in hex and must represent capital letters.
- V E will return requested data in engineering units. N will return normalized data.
- YYY Three digit command number 100...999. Not all numbers are used.
- /ZZ Specifies color table number. The color table will be edited with the bbb.b data which follows. This only needs to be included when using the color tables. The default is for color 0.
- bbb.b Number to be entered. Up to 6 digits with a decimal point.
- cr Carriage return.

Refer to the "Appendix" section for the table with the complete listing of all possible programming commands.

VARIABLE DEFINITIONS

This section describes program variables used in all modes of the AdaptaFlow 5000 operation.

The Channel Card Color Tables store the following variables for each color:

PID Proportional (Gain)

PID Initial Kick

PID Tolerance (Dead Band)

Analog Out No.1 through No. 10

These variables represent the 10 table values stored that designate what analog output value is used to cause the flow controller to achieve the specified corresponding Active Set Value (CC.Min). It's value ranges from 0 to 4095 corresponding to analog outputs of 0-10 volts.

Active Set Value No.1 through 10 (CC/Min)

These variables represent the values that the flow controller stores when a new point is learned. It corresponds to an Analog Out value. Values will range from minimum to maximum that the flow controller has successfully output.

Control Variables

PID Proportional (By Color)

This factor determines the strength, or overall magnitude of change depending on the overall response of a particular set of system components. In many cases this value can only be determined by experimenting and it is well advised to start with a relatively low number. Too large a number can cause oscillations. Normal values are 100 to 1000. For paint applications, a starting value of 150 is recommended.

PID Integral

When the steady-state error is excessive, the error can be reduced by providing increased system gain at low frequencies. The integral compensation signal is proportional to the time integral of the error, in other words, the integral

correction signal(I) continues to increase a fixed amount as long as any error is present. When sufficient correction signal has accumulated, then the error will have decayed to within the PID Tolerance.

This variable is used more in slow reacting closed loop systems, where a high proportional (P) gain would cause instability or oscillation. It is recommended to keep this value small and make design changes, if possible, to improve the system hysteresis. For painting systems, this parameter will have very little effect and should be set close to, or at 0.

PID Derivative

The derivative (D) component of the PID formula effects mostly the transient response and is proportional to the rate of change, or derivative of the error signal. Derivative control is useful because in responding to the rate of change of the error, it can produce a significant correction before the magnitude of the error becomes large. This is particularly useful in controlling systems with sudden input or load changes because it produces a control signal while the error is changing. The derivative part of the PID formula works against the proportional part if the general direction is towards the requested value. This is often used to stabilize the instability introduced by high gain factors. This factor, like the proportional factor, is usually adjusted by experimentation.

PID Tolerance (By Color)

This is the margin above and below the Set Point that determines when the PID pursuit of reaching the Set Point will be stopped. This window is also referred to as a "dead band". Depending on the mechanics of the system, it is advisable to start with a large window at first. Then, when system tuning results in stable operation, this number can be reduced. Note that a small value here, will effect the stability of the "Stable LED" and the Setpoint Achieved status bit. This value is entered in hundredths of Hertz. A value of 100 represents 1.00Hz feedback from the flow meter. A reasonable setting is 10-20.

PID Delta Step

This parameter defines the difference between flow rates stored in the color table. This is expressed in hundredths of Hertz so that a value of 100 would equal 1.00 Hz feedback from the flow meter. This parameter's original intent was to function as a noise filter on a hard-wired system, but may still be used for Smart Node applications. The difference between requested and actual flow rates must exceed this parameter in order for the data table values to be used for the analog control output calculation ("data table pick"). If the difference between requested and actual is less than the PID Delta Step, then the analog control output will ramp fluid flow up or down under PID control only and without the use of the data table values in conjunction with the PID Death Delay.

A good rule of thumb is to set the PID Delta Step equal to the difference between minimum and maximum flow rates divided by 10. This depends on flow range and is typically a value between 10-50.

PID Initial Kick (By Color)

The Initial Kick is beneficial in cases where the regulator has a large hysteresis. The kick value will be applied to the analog output if there is a Set Value present, no fluid flow and the analog output is less than the kick value. This is programmed in a range from 0000 to 4095 steps which corresponds to 0-10 VDC. The correct setting is that value that will guarantee a minimal flow rate above the fluid regulator's cracking pressure.

PID Death Delay

This parameter specifies the amount of time the system will wait before closing the PID loop after a requested change in flow rate. The delay initiation starts from the selection of a new set point input or a table pick. Note that a table pick is performed only when there is a change in requested flow rate and not during trigger on and off. This value represents hundredths of a second, therefore a value of 100 would equal 1 second. In some cases the delay is the best way to make the PID wait for a steady-state flow.

Analog In Gain (mAs Gain)

This parameter is utilized when the hardware analog input is used. This value is used to set the full scale range and represents the maximum flow rate for the maximum voltage in.

This parameter will scale the 0-10 volt input signal to the flow rate in engineering units/volt.

For example:

If 10 VDC = 1000 cc/min, Then

$$\frac{1000}{10 \text{ VDC-Analog in Offset}} = \text{Gain}$$

With an Analog in Offset of 1 VDC, Then

$$\frac{1000}{10 \text{ VDC}-1 \text{ VDC}} = 111.1 \text{ cc/min -or- } 1 \text{ VDC} = 111.1 \text{ cc/min}$$

Analog In Offset (mAs In Offset)

The requested flow rate can be either a hard wired analog input or programmed via the serial interface. It should be noted that the hard wired analog input is always active, even when operating in serial communication mode. The controller will recognize an input to the hardware analog input terminal if the voltage exceeds the threshold set up by this parameter. This is programmed with a value of 0-4095 which corresponds to a 0-10 VDC threshold. The Volts In Offset is used in a situation where there is not an exact 0VDC at the low point of the analog input.

Cutoff Frequency

This parameter defines the minimum frequency from the flowmeter to assume that the atomizer is triggered on. This value is entered in hundredths of Hertz. A typical value would be 50.

Digital Set-Value

This number has to be programmed in order to generate a flow rate in the PID mode if the external 0-20 ma Set-Value is not connected. This is considered the digital set value. It is important to know that the analog input Set-Value is overriding.

Flow Rate Instantaneous

This is the "raw" incoming frequency from the flow meter.

Flow Rate Mellow

This is the flow rate with a digital filter applied.

Totalizer

Value for total accumulated fluid delivered between totalizer reset signals. This value can be zeroed by a software command or by a hardware reset. This can be used as a subtotal or intermediate total to account for fluid delivered per job or shift, etc.

Grand Totalizer

The grand total is a product of adding the Totalizer for A value to the previous Grand Total Value. Whenever the intermediate totalizer value is zeroed (software or hardware) the total of A is added to the Grand Total.

Active Set Value for PID (By Color)

The active set value (requested flow command) is either the value calculated by taking the analog input signal with the Analog Input Scaler or by setting the Digital Set Value for PID variable by a software command. The analog input is the overriding set value. The analog input is active if it is greater than the Analog Input Offset value.

Digital Set Value for PID

The requested flow rate is determined by this variable if the analog input is not used.

Sample Amount

This parameter determines the update time that the PID control loop utilizes to read the flow meter feedback data. This parameter will have an effect on how fast the PID loop compensates for differences in fluid deliveries. The sample amount is used in a digital filter formula to calculate the actual rate. The update for the rate will become slower as this value is increased. The formula for the filter is:

$$\text{Flow Rate A Mellow} = (\text{Old Flow Rate A Mellow} \times \text{Sample Amount} + \text{New Rate}) / (\text{Sample Amount} + 1)$$

K-Factor for Rate (KFR)

The KFR is use by the controller to scale the real time flow rate. The decimal point can be programmed by setting the KFR DP Data value. This parameter is also used by the Smart Node Adapter to convert the commanded flow rate and flow rate limits that are specified in cc/min to the frequency command required by the flow controller. The formula for calculating the KFR is:

$$\text{KFR} = 6000 / (\text{X Pulses/Engineering unit})$$

The value of X Pulses per Engineering Unit can be found in the calibration sheets supplied with the flow meter. It is advisable to use numbers greater than 100 and less than 9000.

The KFR can be adjusted per flow meter to achieve minimum error. This can be done simply by measuring the actual flow rate, comparing the measured rate to that displayed on the controller during the measurement and entering a new adjusted KFR value based on the percent error. For example, assume that the displayed flow rate equals 300 cc/min and the measured volume equals 305 cc/min. Also assume that the current KFR value is .682.

$$\frac{\text{Actual} - \text{Displayed}}{\text{Actual}} = \% \text{ Error, Therefore:}$$

$$\frac{305 \text{ cc/min} - 300 \text{ cc/min}}{305 \text{ cc/min}} = 1.63\% \text{ Error}$$

Add 1.63% to the KFR value:

$$.682 \times 1.0163 = .693$$

K-Factor for Total A (KFT)

This parameter is used by the flow controller to scale the totalized flow rate. The decimal point can be programmed by setting the KFT DP Data value. This parameter is also used by the Smart Node Adapter to convert the flow rate total limits that are specified in cc/min to the frequency command required by the flow controller. The formula for calculating the KFT is:

$$\text{KFT} = 10,000 / (\text{X Pulses/Engineering unit})$$

The value of X Pulses per Engineering Unit can be found in the calibration sheets supplied with the flow meter. It is advisable to use numbers greater than 100 and less than 9000.

Engineering Units for KFR

This parameter is a three byte variable programmed in ASCII. This parameter is used by the 76400 to indicate engineering units for the real time flow rate display. Any ASCII characters can be programmed here.

Engineering Units for KFT

This parameter is a three byte variable programmed in ASCII. This parameter is used by the 76400 to indicate engineering units for the totalized flow rate display. Any ASCII characters can be programmed here.

Operating Mode

This parameter tells the flow controller which operating mode to use.

- 1 = monitor mode
- 2 = hard wired mode
- 3 = Node Adaptor mode.

Analog Output Offset (mAs Offset)

The AdaptaFlow 5000 has two analog outputs. The first analog output is used to drive the flow transducer. The second analog output is spare and may be programmed to output any memory location of the flow controller. This programming

is accomplished by utilizing four different variables: Volts 2 Offset, Volts 2 Gain, Volts 2 Shifter and Volts 2 Pointer. This volts 2 Offset adds a DC offset to the specified parameter designated by the volts 2 pointer value. The offset value is in the range of 0-4095. For current Node Adapter applications, this parameter should be set to 0.

This parameter can be used to compensate for differences or errors associated with conversions from 4-20 ma to VDC.

Analog Output Gain (Volts Gain)

This parameter is used to scale the spare analog output. This value acts as a multiplier to the memory location.

Analog Output Shifter (Volts Shifter)

This parameter scales the spare analog output. It acts as a divider to the memory location. For Node Adapter systems, this parameter should be set to 0.

Analog Output Pointer (Volts Pointer)

This parameter specifies which memory location in the flow controller is mapped to the spare analog output. After specifying this location, it may be scaled (multiplied, divided or offset) by three parameters listed above. For Node Adapter systems, this parameter should be set to 0.

Total Limit 1-4

This parameter sets the value of the trip point for flow alarms no. 1 through 4. If the value of the totalizer exceeds this value, the alarm bit is turned on.

Flow Rate Limit 1-4

This parameter sets the value of the trip point for flow rate alarm no. 1 through 4.

Limit Rule 1-4

Determines which type of limit (flow, total or ratio) will cause the limits to turn ON.

| | | |
|--------------------|----|-------------------|
| Limit Rule: | 11 | Total Limit for A |
| | 12 | Rate Limit for A |
| | 13 | Ratio Limit for A |
| | 21 | Total Limit for B |
| | 22 | Rate Limit for B |
| | 23 | Ratio Limit for B |

Margin for Flow Rate 1-4

The Flow Margin represents a +/- tolerance of the programmed flow rate before tripping the limit.

PC CONTROL USING THE GR3000 PROGRAM

Setup

The GR3000 program was written for communication between the AdaptaFlow 5000 and a PC. The program makes setup much easier.

Getting Ready

In order to use a PC there are several things required.

1. An available serial port on the PC and a serial interface cable.
2. The GR3000 program.
3. The power supply card has a serial port on the front of the card. In order to use this port, the power supply card must be pulled out of the rack and SW2 must be placed in the FRONT position. Only one serial interface can be used at any time.

Running the Program

To run the GR3000 program, place the disk into the appropriate drive and type **a:\gr3000** (assuming the disk is in the A drive).

The GR3000 program will automatically search for channels, and in the main menu it will display active channels in green and inactive channels in red.

To setup the variables press "F4" for the Data Editor. Using the arrow keys each variable can be entered.

The GR3000 allows the user to watch the PID loop in action. From the main menu, press the "F6" key for the Line Graph. The line graph displays the PID loop as a graph. Watching the oscillation on the graph will aid in determining the best value for the "PID Proportional" value. From the line graph you can display one channel at a time.

To see the flow rates and setpoints for all of the channels on one screen, from the main menu, push the "F1" key for the Rate & Setpoint Monitor.

Do not forget to set SW2 on the power supply card back to "REAR" after using the GR3000 program. If it is not done, the 76400 will not work.

76400 DISPLAY / CONTROL UNIT

The 76400 is a multi-channel display and interface for the AdaptaFlow 5000 channel cards. This unit is required to program and operate the Adaptaflow 5000 system if a PLC or control computer is not available. The 76400 can be mounted in 1/2 of a 19" rack or panel mounted.

76400 PROGRAM MENUS

Menu Tree

Column 1

Main Menu
 F1=Action Menu
 F1=ESC
 F2=Totals
 F1=ESC
 F2=Rate
 F3=Reset All
 F3=Grand Totals
 F1=ESC
 F2=Rate
 F3=Reset All
 F2=Single Channel Display 1
 F1=ESC
 F2=UP
 F3=DN
 F4=Reset
 F5=DI+(Single Channel Display 2)
 F1=ESC
 F2=UP
 F3=DN
 F4=Reset
 F5=DI+(Return to Single Channel Display 1 or to Single Channel Display 3 if in PID)
 F1=ESC
 F2=UP (Returns to Single Channel Display 1)
 F3=Dn (Returns to Single Channel Display 1)
 F4=RES (Returns to Main Menu)
 F5=DI+ (Returns to Main Menu)

(Continued-See Column 2)

Column 2

F3=Ratio Display
 F1=ESC
 F2=PGUP
 F3=PGDN
 F4=Programming
 F1=Main Menu(Returns to Main Menu)
 F2=General A
 F1=ESC
 F2=PGUP
 F3=PGDN
 F4=PRGM
 F3=PID Variables
 F1=ESC
 F2=PGUP
 F3=PGDN
 F4=PRGM
 F4=General B
 F1=ESC
 F2=PGUP
 F3=PGDN
 F4=PRGM
 F5=Analog Variables
 F1=ESC
 F2=PGUP
 F3=PGDN
 F4=PRGM
 F6=Limit Variables
 F1=ESC
 F2=PGUP
 F3=PGDN
 F4=PRGM
 1=Limit Rules
 F1=ESC
 F2=PGUP
 F3=PGDN
 F4=PRGM
 2= Ratios
 F1=ESC
 F2=PGUP
 F3=PGDN
 F4=PRGM

(Continued-See Column 3)

Column 3

3=Linearizer
 F1=ESC
 F2=PGUP
 F3=PGDN
 F4=PRGM

4=Special
 0=Enter Channel
 F1=ESC
 F2=PGUP
 F3=PGDN
 F4=ENT

F5=Search Channels
 F6=Utility
 F1=Escape to Main Menu
 Enter Pass Code=XXXXXX
 F1=Escape to Main Menu
 F2=Defaults on Next Power Up
 F3=Manipulate mA's Out
 F1=ESC
 F4=New Value
 F1=ESC
 F2=CLR
 F5=DP
 F6=ENT

F4=Manipulate Vos Out
 F1=ESC
 F2=CLR
 F5=DP
 F6=ENT

(Continued-See Column 4)

Column 4

F5=Force a Channel Number
 F1=ESC
 F2=PGUP
 F3=PGDN
 F4=ENT

F6=Channel Specific Info
 F1=ESC
 F2=PGUP
 F3=PGDN
 F6=PRGM

1=Action Ratio
 F1=ESC
 F2=CH-Swap
 F3=DI+(To Jobs Total Screen)
 F1=ESC
 F2=CH-Swap
 F3=DI+

F4=RES

2=Quick Programming
 F1=ESC
 F2=MTR
 F3=UNITS
 F4=Channel
 F5=Meter Units selected for the A input
 F6=Meter Units selected for the B input

```

***** MAIN MENU *****
F1 = ACTION DSP          F2 = SINGLE CHA
F3 = RATIO DSP           F4 = PROGRAMMING
F5 = SEARCH CHA         F6 = UTILITY

1 = ACTION RATIO        2 = QUICK PROGR.

Select one of the above above .....
```

Figure 26: Main Menu

In any of the Action or Programming screens the ESCAPE (F1) will return the operator to the Main Menu.

An explanation follows for each of the choices above.

GENERAL OPERATION

Once the 76400 is installed and programmed, the Action screen, Single Channel screen or the Ratio screen will serve as the normal operating screens.

NOTE

- ▶ All AdaptaFlow Channel Card analog inputs and outputs are 0-10 VDC. All reference to the term 'mAs' in the 76400 programming screens refer to voltage. 4-20 ma I/O options were included on earlier versions of flow control. Currently, 0-20ma equals 0-10 volts (4 ma = 2 Volts).
- ▶ Ratio Mode of operation is not available with the AdaptaFlow 5000 system, therefore disregard the programming functions pertaining to Ratio operation. Ratio control is available with other ITW Ransburg flow control systems. Contact your ITW Ransburg representative for more information.

The Action screens will display the Fluid Rates, Totals and Grand totals for up to 12 active channels. The Totals and Grand Totals can be reset to zero by pushing the F6 key.

NOTES:

F1 - ACTION DISPLAY

| CNR | RATE | CNR | RATE |
|--|----------|-----|----------|
| 0 1 | XXXXX.X | 0 7 | XXXXX.X |
| 0 2 | XXXX.XX | 0 8 | XXXX.XX |
| 0 3 | XXX.XXX | 0 9 | XXX.XXX |
| 0 4 | XXXX.XX | 1 0 | XXXX.XX |
| 0 5 | XXXXX.X | 1 1 | XXXXX.X |
| 0 6 | XXXXXXXX | 1 2 | XXXXXXXX |
| F1 = ESC F2 = TOTALS F3 = GRAND TOTALS | | | |

Figure 27: F1=Action DSP (Rate)

| CNR | TOTAL | CNR | TOTAL |
|---|--------|-----|--------|
| 0 1 | XXXXX. | 0 7 | XXXXX. |
| 0 2 | XXXXX. | 0 8 | XXXXX. |
| 0 3 | XXXXX. | 0 9 | XXXXX. |
| 0 4 | XXXXX. | 1 0 | XXXXX. |
| 0 5 | XXXXX. | 1 1 | XXXXX. |
| 0 6 | XXXXX. | 1 2 | XXXXX. |
| F1 = ESC F2 = RATE F3 = RESET ALL | | | |

Figure 28: Action DSP (Total)

| CNR | GRAND TOT | CNR | GRAND TOT |
|---|-----------|-----|-----------|
| 01 | XXXXX. | 07 | XXXXX. |
| 02 | XXXXX. | 08 | XXXXX. |
| 03 | XXXXX. | 09 | XXXXX. |
| 04 | XXXXX. | 10 | XXXXX. |
| 05 | XXXXX. | 11 | XXXXX. |
| 06 | XXXXX. | 12 | XXXXX. |
| F1 = ESC F2 = RATE F3 = RESET ALL | | | |

Figure 29: Action DSP (Grand Totals)

F2 - SINGLE CHANNEL DISPLAY

Monitor Mode

NOTE

► **The next two displays are for Monitor Mode ONLY.** The Single Channel screen will display all of the operational information needed for the specific channel selected. There are actually 2 single channel screens for each channel and 1 special transducer value screen for channels in the PID operating mode. The first screen is shown below.

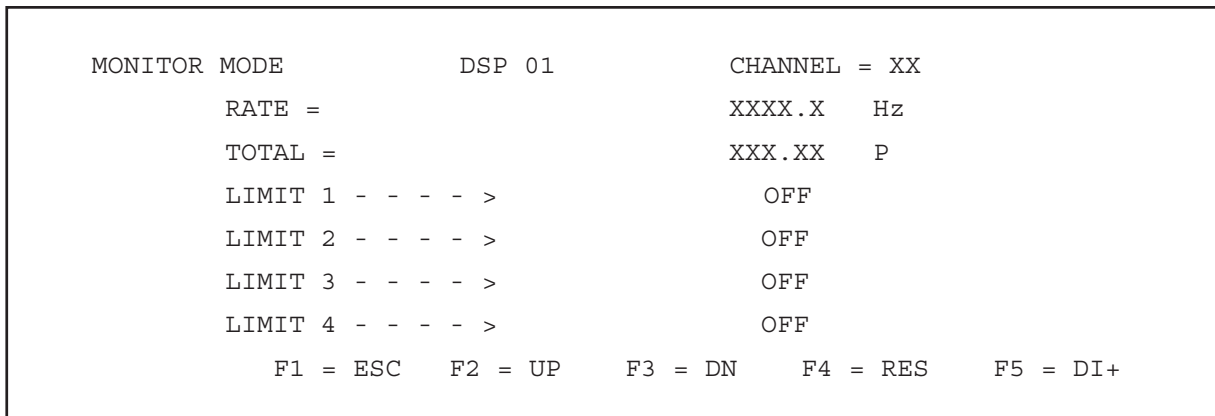

Figure 30: Single Channel Display 1

F2 will page the operator up through the channels.

F3 will page the operator down through the channels.

F4 will reset the Total.

F5 will call up the second Single Channel screen.

The second of the 2 single channel display screens is shown below. This screen is entered by selecting F5 = DI+ in the first screen.

```
MONITOR MODE           DSP 02           CHANNEL = XX

    mAs IN=XX.XX           mAs OUT=XX.XX
    Vs  IN=X.XXX           Vs  OUT=X.XXX

GRAND TOTAL = XXXXXXXX.
LINEARIZER  = OFF

F1 = ESC   F2 = UP   F3 = DN   F4 = RES   F5 = DI+
```

Figure 31: Single Channel Display 2

F2 will page the operator up through the channels.

F3 will page the operator down through the channels.

NOTE

► **Paging up or down will also set the screen back to the first single channel display screen.**

F4 will reset the Grand Total.

F5 will call up the first single channel screen in Monitor Mode.

F2 - SINGLE CHANNEL DISPLAY

PID Mode

| | | | |
|----------|-------------------|---------|-------------------|
| P I D | MODE | DSP 01 | CHANNEL = XX |
| | RATE = | | XXXX.X Hz |
| | SET = | | XXX.XX Hz |
| | TRANSPARENT - - > | | OFF |
| | HOLD ANALOG - - > | | OFF |
| | HOLD TOTAL - - > | | OFF |
| | SET REACHED - - > | | OFF |
| F1 = ESC | F2 = UP | F3 = DN | F4 = RES F5 = DI+ |

Figure 32: Single Channel Display 1

F2 will page the operator up through the channels.

F3 will page the operator down through the channels.

F4 will reset the Total.

F5 will call up the second Single Channel screen.

The second of the 2 single channel display screens is shown below. This screen is entered by selecting F5 = DI+ in the first screen.

```

P I D      MODE          DSP 02          CHANNEL = XX
mAs IN=XX.XX          mAs OUT=XX.XX
Vs  IN=X.XXX          Vs  OUT=X.XXX

TOTAL = XXXXXXXX.    P
LINEARIZER = OFF

F1 = ESC   F2 = UP   F3 = DN   F4 = RES   F5 = DI+

```

Figure 33: Single Channel Display 2

F2 will page the operator up through the channels.

F3 will page the operator down through the channels.

NOTE

- ▶ Paging up or down will also set the screen back to the first single channel display screen.

F4 will reset the Grand Total.

F5 will call up the first single channel screen in PID Mode.

If the channel selected for Single Channel display is in the PID operating mode, there is an additional display screen which shows five closed loop set points and five corresponding transducer values. They are the Scratch Pad Values for the PID channel.

```

P I D      MODE          DSP 03          CHANNEL = 01
                                SCRATCH PAD VALUES
01SET =00000.0          X-DUCER=0000
02SET =00000.0          X-DUCER=0000
03SET =00000.0          X-DUCER=0000
04SET =00000.0          X-DUCER=0000
05SET =00000.0          X-DUCER=0000
F1 = ESC   F2 = UP   F3 = DN   F4 = RES   F5 = DI+

```

Figure 34: Single Channel Display 3

NOTE

- ▶ The F2 and F3 keys will return the operator back to Single Channel display 1. Any other key will return the user to the main menu. This display is NOT available in Monitor Mode.

F3 - RATIO DISPLAY

The Ratio Display screen can be selected from the Main Menu using F3. In this operation screen, both of the rates from frequency inputs A and B are shown and the Ratio A/B is computed and displayed as shown below.

| | | |
|-------------------|-------------|-----------|
| RATIO DISPLAY FOR | CHANNEL XXX | |
| RATE A= | XXX.X | |
| RATE B= | XXX.X | |
| RATIO A/B= | XXX.XX | |
| SET RATIO= | XX.XX | |
| F1 = ESC | F2 = PGUP | F3 = PGDN |

Figure 35: Ratio Display

F2 will page the operator up through the channels.

F3 will page the operator down through the channels

To show multiple channel displays of ratio, refer to the ACTION RATIO section from the MAIN MENU.

NOTES:

F4 - PROGRAMMING

Selecting Programming from the Main Menu will call up the screen below.

```
***** PROGRAMMING MENU *****  
  
F1=MAIN MENU (ESC)           F2= GENERAL A  
F3=PID VARIABLES            F4= GENERAL B  
F5=ANALOG VARIAB.          F6= LIMIT VAR.  
    1=LIMIT RULES           2= RATIOS  
    3=LINEARIZER            4= SPECIAL  
    0=ENTER CHANNEL         (CURRENT = XXX)  
Select one of the above.....
```

Figure 36: Programming Menu

For each of the selections above, instructions will be provided to access and program the desired variable. This part of the manual is not intended to describe the effect of each variable. See the Program Control Section for detailed variable information.

An explanation follows for each of the choices above.

F1 - Main Menu (Esc)

This key simply returns out of the Programming screen to the Main Menu for the Programming screens.

F2 - General A

```

*** GENERAL VARIABLES ***      CH = XXX
-----> KFR FACTOR =          XXXX.X
RATE ENG. UNIT =              ??
KFT - FACTOR =                XXXXX.
TOTAL ENG. UNIT =             ??
SAMPLE AMOUNT =               XXXXX.
CUTOFF FREQ. =                XXXX.X
F1 = ESC   F2 = PGUP   F3 = PGDN   F4 = PRGM

```

Figure 37: General A Menu

NOTE

- In the General A screen there are four variables which are accessed by F2 = PGUP. They are:

```

OPERATING MODE = XXXXX.
LINEARIZER     = XXXXX.
IDEAL RATIO    = XXX.XX
RATIO DISPLAY  = XXX.XX

```

Each of the variables shown on the screen can now be moved into the first position, indicated by the arrow at the top left, then programmed. To move a variable into the top position for programming, use the F2 and F3 keys. As the variables are paged UP, more appear in the programming window. The four that are related to GENERAL A variables are as shown in the note above.

When the desired variable is moved to the arrow, select F4 = PROGRAM. The 76400 will then ask for the pass-code.

```

ENTER PASS CODE = XXX
The code is "4146"

```

NOTE

- The pass-code only need be entered once to gain access throughout the programming process. If the programmer returns to any of the Action screens, the 76400 will request the pass-code again for further programming.

Key in the correct value and enter with F6.

F3 - PID Variables

```

* * * * PID VARIABLES * * * *   CH = XXX
-----> PID PROPORT.           =   XXXXX.
      PID INTEGRAL             =   XXXXX.
      PID DIRIVATIV            =   XXXXX.
      PID TOLERANCE            =   XXXX.X
      PID DELTA STEP           =   XXXX.X
      PID INIT. KICK           =   XXXXX
F1 = ESC   F2 = PGUP   F3 = PGDN   F4 = PRGM

```

Figure 38: PID Variable Menu

NOTE

► In the PID VARIABLES screen there is 1 variable which is accessed by F2 = PGUP. It is:

PID DEATH DEL. = XXXX

When the desired variable is moved to the arrow, select F4 = PROGRAM. The 76400 will then ask for the pass-code.

ENTER PASS CODE = XXXX
The code is "4146"

Key in the correct variable value and enter with F6.

F4 - General B

```

* * * B CHANNEL VARIABLES * * *   CH = XXX
-----> KFR - FACTOR B           =   XXXX.X
      RATE B UNITS               =   ??
      KFT - FACTOR B             =   XXXXX.
      TOTAL B UNITS              =   ??
      SAMPLES FOR B              =   XXXXX.
      CUTOFF FRE. B              =   XXXX.X
F1 = ESC   F2 = PGUP   F3 = PGDN   F4 = PRGM

```

Figure 39: General B Menu

When the desired variable is moved to the arrow, select F4 = PROGRAM. Enter the pass-code as described previously. Enter the correct variable data and enter with F6.

F5 - Analog Variables

| | | | |
|----------|------------------|-----------|-----------|
| * * * | ANALOG VARIABLES | * * * | CH = XXX |
| -----> | mAs OFFSET | = | XXX.XX |
| | mAs GAIN | = | XXXXX. |
| | mAs SHIFTER | = | XXXXX. |
| | mAs POINTER | = | XXXXX. |
| | VOLTS OFFSET | = | XX.XXX |
| | VOLTS GAIN | = | XXXXX. |
| F1 = ESC | F2 = PGUP | F3 = PGDN | F4 = PRGM |

Figure 40: Analog Variable Menu

NOTE

- In the ANALOG VARIABLES screen, there are 4 more variables which are accessed by F2 = PGUP. They are:

Volts SHIFTER = XXXXX.
 Volts POINTER = XXXXX.
 mAs IN OFFSET = XXX.XX
 Vos IN OFFSET = XXX.XX

When the desired variable is moved to the arrow, select F4 = PROGRAM. Enter the pass-code as described previously. Enter the correct variable data and enter with F6.

F6 - Limit Variables

```

* * * LIMIT VARIABLES * * *      CH = XXX
-----> TOTAL LIMIT 1      =      XXXXX.
      TOTAL LIMIT 2      =      XXXXX.
      TOTAL LIMIT 3      =      XXXXX.
      TOTAL LIMIT 4      =      XXXXX.
      FLOW LIMIT 1       =      XXXX.X
      FLOW MARGIN 1     =      XXXX.X
F1 = ESC   F2 = PGUP   F3 = PGDN   F4 = PRGM

```

Figure 41: Limit Variable Menu

NOTE

► In the LIMIT VARIABLES screen, there are more variables which are accessed by F2 = PGUP. They are:

```

FLOW LIMIT 2      = XXXX.X
FLOW MARGIN 2    = XXXX.X
FLOW LIMIT 3      = XXXX.X
FLOW MARGIN 3    = XXXX.X
FLOW LIMIT 4      = XXXX.X
FLOW MARGIN      = XXXX.X

```

The Flow Margin will operate as a +/- of the programmed amount before tripping the Limit. For instance, if Flow Limit 1 were programmed to 100 cc/min, the Limit 1 would turn on anytime the Flow Rate went below 90 cc/min or above 110 cc/min.

1 - Limit Rules

```

* * * * * LIMIT RULES * * * * *                CH = XXX
-----> LIMIT 1 RULE          =          XXXXX.
      LIMIT 1 RULE          =          XXXXX.
      LIMIT 1 RULE          =          XXXXX.
      LIMIT 1 RULE          =          XXXXX.
      RATIO 1 +/- %         =          XXXXX.
      RATIO 2 +/- %         =          XXXXX.

F1 = ESC   F2 = PGUP   F3 = PGDN   F4 = PRGM
    
```

Figure 42: Limit Rules Menu

F2 = PGUP will access RATIO 3 and 4.

F4 = PRGM will cause the 76400 to ask for a Pass-Code. Enter "4146". Key in the desired variables and Enter with F6.

| <u>LIMIT RULE</u> | <u>FUNCTION</u> |
|-------------------|-------------------------|
| 11 | Total Limit for A input |
| 12 | Rate Limit for A input |
| 13 | Ratio Limit for A input |
| 21 | Total Limit for B input |
| 22 | Rate Limit for B input |
| 23 | Ratio Limit for B input |

If any of the above is selected to trigger a limit, the next step is to program the Trip Point. This is accomplished for Ratio Limits by using F2 to page up to the desired ratio and then pressing the F4 key. The Total Limit, Flow Limit and Flow Margin variables are set in the "LIMIT VARIABLES" menu.

2 - Ratios

```

* * * * * RATIOS * * * * *                CH = XXX
-----> RATIO 1 +/- %       =          XXXXX.
      RATIO 2 +/- %       =          XXXXX.
      RATIO 3 +/- %       =          XXXXX.
      RATIO 4 +/- %       =          XXXXX.

F1 = ESC   F2 = PGUP   F3 = PGDN   F4 = PRGM
    
```

Figure 43: Ratios Menu

The Ratios screen allows the programmer to set the error percentage at which the limits would turn on if the AdaptaFlow is in the Ratio operating mode. The calculation for the actual Ratio is input A/input B. The Ideal Ratio is strictly a programmable point that the desired ratio should hold. Therefore, the percentage of error between the Actual and Ideal Ratio can control the Limit outputs if so programmed. For example, if the Ideal ratio were programmed to 2 (2 to 1 ratio), and the Actual Ratio measured were 2.2, the percentage of error between the two would be 10%. If the Limit Rule was set for Ratio and the Ratio error % were programmed for 10% or less, then the limit output would turn on.

3 - Linearizer

```

* * * LINEARIZER PROGRAM * * *      CH = XXX
POINT 01---> XXXX.X      ERROR = + XXX.XX
POINT 02---> XXXX.X      ERROR = + XXX.XX
POINT 03---> XXXX.X      ERROR = + XXX.XX
POINT 04---> XXXX.X      ERROR = + XXX.XX
POINT 05---> XXXX.X      ERROR = + XXX.XX
POINT 06---> XXXX.X      ERROR = + XXX.XX
F1 = ESC   F2 = PGUP   F3 = PGDN   F4 = PRGM

```

Figure 44: Linearizer Menu

The table continues for up to 10 points by F2 = PGUP.

```

POINT 07 ----> XXXX.X      ERROR = + XXX.XX
POINT 08 ----> XXXX.X      ERROR = + XXX.XX
POINT 09 ----> XXXX.X      ERROR = + XXX.XX
POINT 10 ----> XXXX.X      ERROR = + XXX.XX

```

Programming the Linearizer is different from the other screens so far in that it will call up the MENU BAR below if F4 = PRGM is selected.

F1 = ESC F2 = POINT F3 = ERROR

The programmer must select either the point or the error percentage for programming. If F2 = POINT is selected the MENU BAR will show the following choices.

F1 = ESC F2 = CLR F5 = DP F6 = ENT

Key in the correct deviation point and enter with F6. Correct any mistakes using the F2 = CLEAR, F5 = DECIMAL POINT.

If the programmer selects F3 = ERROR, the MENU BAR will show the following choices.

F1 = ESC F2 = CLR F3 = SGN F5 = DP F6 = ENT

Key in the correct error percentage and the correct +/- sign using the F3 = SGN. Enter using F6.

4 - Special

If the programmer selects 4 = SPECIAL, the 76400 will return to the programming section last entered. This should be a handy feature when a number of channels need to be programmed in the same manner or if quick changes need to be made for variables commonly used.

0 - Enter Channel
(Current = XXX)

```
* * * * ENTER CHANNEL NUMBER * * * *  
  
CURRENTLY = XXX  
  
F1 = ESC  F2 = PGUP  F3 = PGDN  F6 = ENT
```

Figure 45: Enter Channel Menu

NOTES:

F5 - SEARCH CHANNELS

If the operator selects F5 = SEARCH CHANNELS, the screen will flash the message "...searching for active channels". At this time, the 76400 will start incrementing through all channels and the screen will indicate any active responses as the character I. The 76400 will automatically return to the Main Menu.

F6 - UTILITY FUNCTIONS

The 76400 features some powerful tools for use in system troubleshooting. Changing the variable setting can cause incorrect system operation. Therefore, this warning and special pass-code screen have been added as protection.

```

Because of the sensitive nature
of the variables that can be
manipulated, a special pass code
is in effect !!!

ENTER PASS CODE = XXXXXXXX
F1 = ESCAPE TO MAIN MENU
    
```

Figure 46: Pass Code Menu

The special pass code is **"6377130"**

```

* * * * UTILITY MENU * * * *
F1 = ESCAPE TO MAIN MENU
F2 = DEFAULTS ON NEXT POWER UP
F3 = MANIPULATE mAs OUT
F4 = MANIPULATE VOs OUT
F5 = FORCE A CHANNEL NUMBER
F6 = CHANNEL SPECIFIC INFO
Select one of the above.....
    
```

Figure 44: Linearizer Menu

F1 - Escape to Main Menu

F2 - Defaults on Next Power Up

If the programmer selects F2, the screen will flash:

TURN POWER OFF TO DEFAULT !

When the AdaptaFlow is turned off, all of the programmed information in the memory for each channel will be lost. The information will be replaced with the default settings for every variable. The operating variables would need to be reprogrammed.

F3 - Manipulate mAs Out

If F3 is selected, the screen will first ask for the channel number to be altered. Then the screen below will appear.

```

* * * TRANSPARENT MA s OUT * * *

RATE A =          XXXXX.
RATE B =          XXXXX.
mAs OUT =         XXX.XX
TRANSP.  A (0..4095)  XXXXX.
F1 = ESC   F4 = NEW VALUE
    
```

Figure 48: Transparent MA s Out Menu

If F4 is selected, the MENU BAR at the bottom of the screen will show the following:

F1 = ESC F2 = CLR F5 = DP F6 = ENT

The Transparent A variable can now be altered to any number between 0 and 4095. This will control the analog output control signal to the flow meter transducer.

F4 - Manipulate Vos Out

If F4 is selected, the screen will first ask for the channel number to be altered. Then the screen below will appear.

```

* * * TRANSPARENT VOLTS OUT * * *

RATE A      =          XXXXX.
RATE B      =          XXXXX.
VOLTS OUT   =          XX.XXX
TRANSP. B (0..4095)  XXXXX.
F1 = ESC   F4 = NEW VALUE
    
```

Figure 49: Transparent Volts Out Menu

If F4 is selected, the MENU BAR at the bottom of the screen will show the following:

F1 = ESC F2 = CLR F5 = DP F6 = ENT

The Transparent B variable can now be altered to any number between 0 and 4095. This will control the analog output control signal to the flow meter transducer.

F5 - Force A Channel Number

If F5 is selected, then the screen below will appear.

```

CHANNEL NUMBER TO BE FORCED ON
TO THE CHANNEL CARD IN RACK !!!

CURRENTLY = XXX

F1 = ESC   F2 = PGUP   F3 = PGDN   F6 = ENT
    
```

Figure 50: Force a Channel Number Menu

WARNING

- ▶ This feature is particularly dangerous. There must be only 1 card plugged into the AdaptaFlow rack because the 76400 will force all cards to the new channel number selected.
- ▶ There should never be 2 or more channel cards in the AdaptaFlow rack with the same number. This will result in major communication problems.

When the correct number is selected, enter using F6.

F6 - Channel Specific Info

If F6 is selected, then the screen below will appear.

```

* * * CHANNEL SPECS * * *          CH = XX

VERSION NUMBER   =          1.4
CHANNEL OFFSET   =          00000.

F1 = ESC   F2 = PGUP   F3 = PGDN   F6 = PRGM
    
```

Figure 51: Channel Specs Menu

If the programmer selects F4, the channel Off-set can be programmed.

1 - ACTION RATIO

If 1 is selected, then the screen below will appear.

| CHA | - RATE A | --- | RATE B | --- | -RATIO |
|--|----------|-----|--------|-----|--------|
| 01 | XXXX.X | | XXXX.X | | XXX.XX |
| 02 | XXXX.X | | XXXX.X | | XXX.XX |
| 03 | XXXX.X | | XXXX.X | | XXX.XX |
| 04 | XXXX.X | | XXXX.X | | XXX.XX |
| 05 | XXXX.X | | XXXX.X | | XXX.XX |
| 06 | XXXX.X | | XXXX.X | | XXX.XX |
| F1 = ESC F2 = CH-SWAP F3 = DI+ F4 = RES | | | | | |

Figure 52: Action Ratio Menu

F1 = ESC will return to the Main Menu

F2 = CH-SWAP will show the next 6 channels (7-12)

F3 = DI+ will call up the Job Totals screen as shown below

F4 = RES is inactive for Rate screen

| CHA | - JOB TOTAL - A | - | JOB TOTAL - B | - | -RATIO |
|--|-----------------|---|---------------|---|--------|
| 01 | XXXXX. | | XXXXX. | | XXX.XX |
| 02 | XXXXX. | | XXXXX. | | XXX.XX |
| 03 | XXXXX. | | XXXXX. | | XXX.XX |
| 04 | XXXXX. | | XXXXX. | | XXX.XX |
| 05 | XXXXX. | | XXXXX. | | XXX.XX |
| 06 | XXXXX. | | XXXXX. | | XXX.XX |
| F1 = ESC F2 = CH-SWAP F3 = DI+ F4 = RES | | | | | |

Figure 53: Job Totals Menu

2 - QUICK PROGRAMMING

The Quick Programming section of this manual is intended for the user who wishes to display the Flow Rates and Totals in the desired Engineering Units without any extensive programming involvement. The Flow Meter and Engineering Units can be selected from a menu and entered for each channel.

```
* * * * *      QUICK PROGRAMMING      * * * * *  
  
METER = ZHM - 01      UNITS = CCM      CHA = 01  
  
PRESS F5 TO ENTER FOR CHANNEL A  
PRESS F5 TO ENTER FOR CHANNEL B  
  
F1 = ESC      F2 = MTR      F3 = UNITS      F4 = CHANNL
```

Figure 54: Quick Programming Menu

F1 = ESC will return to the Main Menu

F2 = MTR will page METER through a list of choices.

F3 = UNITS will page UNITS through a list of choices.

F4 = CHANNL will select the channel to be programmed.

F5 = Will enter the Meter and Units selected for the A input.

F6 = Will enter the Meter and Units selected for the B input.

NOTES:

MAINTENANCE

FLOWMETER

Maintenance

To ensure proper operation, the following guidelines should be followed:

1. Flush the meter with solvent or other cleaning fluid when working with a fluid that can dry in the meter. Examples of these fluids are paint, underbody coating, primer, sealant, clear coat, etc.

Flush the meter and line thoroughly at shut down.

If possible, leave flushing fluid trapped in the line at shut down to prevent "sticking" during start-up. If the line is to remain full of liquids at all times, then it is not as critical that the meter be flushed since the fluid will not dry as easily. When flushing, it is recommended that the cycle last for at least 5 seconds or longer. However, there can be cases when the meter will flush in 3 seconds.

2. It is recommended that the meter be recalibrated or checked on a yearly basis to ensure accuracy and repeatability. If a large deviation is noticed, it is possible that the gears and/or shafts need replaced.
3. **Never over spin the meter with air.** It is strongly recommended that the meter not be air blown for more than 30 seconds at a time during the purge cycle. This is demanding on a positive displacement meter when there is no lubricant. If this is ignored, you will find that the shafts will crack on a frequent basis.
4. **Size the meter for the application.** It is important to get the correct size meter for the application. Refer to the Specifications.

Servicing

Flowmeter problems can be caused by improperly filtered fluid. Particulates in the fluid can cause gear binding, resulting in improper signals for the actual flow rate. **Maintain the fluid filters according to the instructions from the filter manufacturer.** If repeated disassembly and cleaning for removal of solids and particulates occurs, inspect the entire fluid supply system and evaluate the system cleaning cycle.

Under normal operation the magnetic sensors or electrical connections will not require replacement.

Disassembly and Cleaning

General

1. Work from a clean, dry bench.
2. It is common practice to always install a new o-ring when the flowmeter is reassembled.
3. Use only lint-free wiper/cloths for cleaning.
4. Refer to the model number of the flowmeter when ordering replacement parts.

If the Flowmeter is to be Removed from the System for Servicing

1. Flush the flowmeter with the system purge.
2. Shut down the fluid control system.
3. Shut off fluid (material) input valve of the affected fluid line.
4. Trigger applicator to remove fluid line pressure.

5. Disconnect the control cable from the flowmeter. (Cover the exposed connections on the cable end.)
6. Remove the flowmeter from the fluid line.

Flowmeter Disassembly

1. Remove the pickup assembly.
2. Loosen and remove all but two opposing housing bolts. Loosen the two remaining bolts until the bolt heads extend beyond the housing recess.

NOTE

► The housing halves are aligned with dowel pins. Separation must be done evenly to avoid damage to the gears and gear shafts.

3. Separate the housing halves evenly by tapping equally on the housing bolts. Keep the separation even until the dowel pins are free.

NOTE

► The internal components are not fixed. When the housing is separated, the gears and shafts may stick to either half or may fall out during disassembly.

4. Once the dowel pins are exposed and the housing halves are free, remove the bolts and separate the housing.
5. Lift out the gears and gear shafts.
6. Clean all parts in the appropriate solvent for the coatings handled by your system. Avoid immersing the pickup or electrical components in ANY solvent.
7. Use a lint-free wiper to remove excess solvent from the cleaned parts.

8. Inspect the gears and gear shafts for signs of wear and/or solidified coating material. Inspect the bushings in both housing halves for wear and/or contaminants.
9. Slide each gear onto a gear shaft and observe that the gear rotates freely on the shaft.
10. Inspect the fluid ports in the lower housing for solidified material. If necessary remove the adapter fittings and clean them. Clean out the fluid ports in the housing.
11. Clean all mating surfaces.
12. Remove and discard the o-ring. Clean the o-ring groove to ensure proper seating of the replacement o-ring. Use exact replacement parts.
13. Fit a new o-ring into the lower housing groove. Do not use grease or other lubrication on the o-ring.
14. Install the shafts and gears in the lower housing. The gears and shafts are interchangeable and will fit either alignment hole.
15. Fit the two housing halves together. Don't force the parts together. Maintain alignment to avoid gear and gear shaft damage. Pay attention to any alignment marks (on the side of the flow meter) so proper orientation of the electrical connector is maintained. Be sure the o-ring does not slip from the groove during reassembly.

NOTE

► Although the manufacturer of the flowmeters installs alignment pins in the flowmeters to prevent the two halves from being assembled incorrectly, sometimes these alignment pins fall out or stick to the wrong half of the flowmeter. This results in an ability to assemble the meters incorrectly.

NOTE

► There is a small oval-shaped relief cut in both halves of the flowmeter. It is imperative that the relief on the top section be on the inlet side of the meter and the relief cut on the bottom section be on the fluid outlet side. There is an arrow on the label that is riveted to the top section, however, there is not an arrow on the lower section. There are alignment marks on the side of both halves (typically a number) that can also be used to line up with each other to ensure proper assembly.

16. Insert and tighten the housing bolts to 11 ft.-lbs. Tighten all bolts equally and alternately in a clockwise direction. This will ensure proper seating of the o-ring.



CAUTION

- DO NOT OVERTIGHTEN.

17. Replace the pickup, inspect the electrical components and leads for any physical damage. Repair or replace as necessary.

Automatic Cleaning of the Flowmeter

Fluid Line Air Purges

Air purges are often used in automatic coating operations for rapid color changes and to minimize the amount of solvent required to flush-out the old color. Special considerations must be made when using air purges through the flowmeter.

1. Air purges DO NOT provide the lubrication the flow meter gears require. Lubrication is normally provided by the metered fluid or solvent.

2. Air purges can cause some coating materials to "dry" on the flowmeter shafts and gears, thus affecting the performance characteristics of the flowmeter.
3. Excessively long air purges will cause premature gear and shaft failure.
4. All clean cycles should begin with a solvent push to prevent drying of coating material on flowmeter parts.
5. Solvent and air "chop" cycles are recommended as the most efficient way of flushing flowmeters.
6. Air purge cycles are not recommended in waterbased applications.

Metallic Paints and Waterborne Paints

Metallic and waterborne paints both require special cleaning procedures and considerations. The information about each fluid type cannot be applied to all systems verbatim. It must be considered as a guideline ONLY. Use it to establish the procedures for purging and cleaning of the fluid lines and the required frequency of flow meter servicing. This information also applies to high-solid content materials that are non-metallic.

Whether using metallic or waterborne paints, the basic procedure is the same: periodic disassembly, inspection and cleaning of the flow meter gears and gear housing. The frequency of the periodic inspections should be determined at the application site by operator experience.

Under normal operation, the flowmeters will require periodic disassembly and inspection. The frequency of these inspections depends on:

1. The type of fluid used.
2. The cleaning sequences used when changing colors or materials.
3. How often colors or materials are changed.
4. Use of the proper material filters and the maintenance of them.

Establishing Cleaning Procedures and Cleaning Frequency

To establish the normal inspection period for an installation, and to evaluate the effectiveness of the cleaning sequences, follow the guidelines listed below.

1. **Disassemble and inspect the flowmeter** after 40 hours of normal operation. Use the procedures listed in this section.

If the inspections show any of the conditions listed in this section under "Conditions To Look For," the cleaning sequences should be evaluated and changed.

If the inspections DO NOT indicate the conditions listed, reassemble the flowmeter.

2. **Disassemble and inspect the flowmeter** after an additional 40 hours of normal operation and repeat the inspections.

By repeating the inspections at 40 work-hour intervals, establish the optimum time for normal preventive flowmeter maintenance inspections and cleanings. To keep down time to a minimum, have a spare, clean flowmeter on hand to "swap out" with a flowmeter being removed for servicing or replacement.

Conditions to Look For:

1. Residue buildup on the flowmeter gears.
2. The gears do not spin freely on the shafts.
3. The shafts show bluish discoloration from overheating.

Residue Build-Up

Residue buildup will affect the performance of a flowmeter. This causes loss of metering accuracy and necessitates recalibration of the flowmeter. As more and more buildup occurs, recalibration is required more often.

1. Use the disassembly/inspection procedures listed in this section.
2. If the cause of the buildup was the automatic purging/cleaning procedures, those procedures may require changing. This would depend on how often the residue must be removed with the methods indicated.

Gear Rotation Problems

When using waterbased paints, "tacky" residue buildup may cause the flowmeter gears to bind or cease rotating. This is usually an indication that improper cleaning solvents and/or cleaning sequences are being used.

If gear rotational problems occur:

1. Remove the residue using the same procedures listed above.
2. Check the cleaning cycle sequences and correct them if necessary.
3. Use the correct cleaning solvent for the coating material.

Gear and Shaft Overheating

Overheating of the gears and gear shafts can result from excessively long air purges which can cause overspeeding of the flowmeter gears.

1. Inspect the shafts for signs of overheating (bluish discoloration) and excessive wear.
2. Check that the gears rotate freely on the shafts.
3. If overheating or binding is evident, the cause of the problem should be determined **before** installing another flowmeter in the system.
4. Check the cycle times and the air pressures used for the purges.

| General Problem | Cause | Solution |
|---|---|--|
| <p>No fluid flow indicated at PLC or 76400 Controller (Continued)</p> | <p>2. No fluid flow feedback from the flowmeter (Continued)</p> <p>3. PLC or 76400 not communicating to the Channel Module(s) correctly</p> | <p>b. If an oscilloscope is available, check for a signal at the flowmeter pickup input to the AdaptaFlow Card Rack mother board, J8,J10,J12 or J14 depending on the channel. Inspect or replace the Channel Card if a signal is present. Make sure to set up the new Channel Card correctly. Refer to the Installation Section.</p> <p>c. For flow meter pickup systems that use intrinsic safety barriers: check for a flowmeter signal at the input to the intrinsic barrier. If the flow signal is present at the input, but not the output, replace the intrinsic barrier. Otherwise the problem is with the flowmeter pickup or wiring.</p> <p>d. For fiber optic flowmeter pickup systems: check for the signal at the output of the fiber optic receiver. If no signal is present, then the problem is the fiber optic cable or flow meter pickup.</p> <p>e. If a separate power supply voltage is being used for the flowmeter pickup device, input to terminal +V-PU on the Card Rack Mother Board, then check Fuse F1 on the Power Supply Card.</p> <p>3a. If using a Node Adapter Card, verify that the CPU and ACTIVE leds located on the front panel are lighted. See also symptoms #4 and #5.</p> <p>b. If using the 76400 Display Module, verify that the correct operating mode and variables are programmed correctly. Refer to the 76400 Section.</p> |
| <p>Erratic fluid flow displayed</p> | <p>1. Loose or faulty wiring</p> <p>2. Loose or damaged flowmeter fiber optic cable</p> <p>3. Electrical interference</p> | <p>1. Check for faulty or loose wiring from the flowmeter pickup device to the AdaptaFlow Bus Board.</p> <p>2. Inspect fiber optic cable and replace if necessary.</p> <p>3. * Try to isolate the cause of the interference. Observe the flow controller display and look for patterns such as the operation of another nearby machine or the operation of high voltage, etc.</p> |

Figure 55 (Continued): Troubleshooting Guide

| General Problem | Cause | Solution |
|--|---|---|
| Erratic fluid flow displayed (Continued) | 3. Electrical interference (Continued) | a. When the spray system is charged to high voltage, it is possible for the fiber optic cable to carry a small amount of static charge back to the receiver along the cable jacket, especially if the cable jacket has been exposed to high humidity, condensation or moisture. The erratic readings can be minimized by connecting terminal 8 on the 76017 to a panel ground. If a panel ground is not available, connect terminal 8 to terminal 2. b. Make sure central grounding is established as described in the Installation Section. |
| Fluid flow not stable | 1. Flowmeter feedback is erratic 2. Electrical interference 3. Control settings incorrect 4. Wrong paint loaded or chosen in color tables 5. Communication problem with PLC processor causing erroneous control variables to be sent to the AdaptaFlow 6. Faulty Node Adapter Module (If used) 7. Fluid supply to applicator is erratic | 1. See Symptom #2. 2. See Symptom #2. 3a. Make sure that the AdaptaFlow is in the correct mode. See Operation and Program Control . b. Make sure that the control variables are set to the correct values. 4. Make sure that the correct paint (color) is being used and that it is the proper viscosity. 5. Check communication protocol. 6. Make sure that the CPU and ACTIVE led's located on the front of the Node Adapter Card are on. 7a. Check for air leaks in pilot signal to fluid regulator. b. Check the fluid regulator and replace if necessary. c. Check the fluid supply pressure and flow from paint source. |

Figure 55 (Continued): Troubleshooting Guide

| General Problem | Cause | Solution |
|--|--|---|
| No communication with a single AdaptaFlow Channel Module | 1. Faulty Channel Module | 1. Replace. |
| No communication with all AdaptaFlow Channel Modules | 1. Loose or faulty wiring 2. PLC RIO port not functioning 3. Node Adapter Module | 1. Check communication wiring from PLC, PC or 76400. 2a. Bad PLC RIO port. b. PLC not set up correctly or in wrong mode. 3a. Node Adapter is not configured correctly. See the Installation Section. b. Bad Node Adapter. Replace. |
| No Card Rack power | 1. No 24VDC power input to Card Rack 2. Fuse blown on Power Supply Card | 1a. Make sure that all disconnects or power switches from the distribution panel are on. b. Check for 24 VDC at the output of the main power supply. c. Check for blown fuses on the main power supply. 2. Check Fuse F2 on the Power Supply Card. |

Figure 55 (Continued): Troubleshooting Guide

PARTS IDENTIFICATION

| ADAPTAFLOW 5000 - PARTS LIST | |
|-------------------------------------|--|
| Part # | Description |
| 73877-01 | Flow Meter, .001 to 0.25 GPM |
| 73877-02 | Flow Meter, 0.02 to 2.0 GPM |
| 73877-03 | Flow Meter, 0.1 to 7.0 GPM |
| 73877-08 | Flow Meter, 0.01 to 0.5 GPM |
| 75914-10 | Helical Gear Flowmeter, 0.003 to 1 GPM |
| 75914-40 | Helical Gear Flowmeter, 0.1 to 11 GPM |
| 75914-100 | Helical Gear Flowmeter, 0.25 to 26 GPM |
| 75955-01 | Flowmeter, 0.01 to 0.5 GPM |
| 75955-02 | Flowmeter, 0.02 to 2.0 GPM |
| 75955-03 | Flowmeter, 0.1 to 7.0 GPM |
| 75955-04 | Flowmeter, 0.01 to 0.5 GPM, S.S. with Tin Coating (Waterborne coatings) |
| 75955-05 | Flowmeter, 0.02 to 2.0 GPM, S.S. with Tin Coating (Waterborne coatings) |
| 76021-30 | Fiber Optic Cable Assembly, 30 ft. |
| 76021-45 | Fiber Optic Cable Assembly, 45 ft. |
| 76021-60 | Fiber Optic Cable Assembly, 60 ft. |
| 76021-100 | Fiber Optic Cable Assembly, 100 ft. |
| 75956 | Fiber Optic Transmitter |
| 76019 | Fiber Optic Transmitter |
| 76018-01 | Transmitter for the 75955 Series Flowmeter, Sourcing Output (PNP) |
| 76018-02 | Transmitter for the 75955 Series Flowmeter, Sinking Output (NPN) |
| 76020-01 | Fiber Optic Pickup System. Includes 75956 Transmitter and 30 ft. of Fiber Optic Cable |
| 76020-02 | Fiber Optic Pickup System. Includes 75956 Transmitter and 45 ft. of Fiber Optic Cable |
| 76020-03 | Fiber Optic Pickup System. Includes 75956 Transmitter and 60 ft. of Fiber Optic Cable |
| 76020-04 | Fiber Optic Pickup System. Includes 75956 Transmitter and 100 ft. of Fiber Optic Cable |
| 76020-05 | Fiber Optic Pickup System. Includes 76019 Transmitter and 30 ft. of Fiber Optic Cable |
| 76020-06 | Fiber Optic Pickup System. Includes 76019 Transmitter and 45 ft. of Fiber Optic Cable |
| 76020-07 | Fiber Optic Pickup System. Includes 76019 Transmitter and 60 ft. of Fiber Optic Cable |
| 76020-08 | Fiber Optic Pickup System. Includes 76019 Transmitter and 100 ft. of Fiber Optic Cable |
| 76015 | Transmitter for the 73877-08 Flowmeter |
| 73864-91 | Transmitter for 73877-01 Flowmeter |
| 73864-92 | Transmitter for 73877-02 Flowmeter |
| 73864-93 | Transmitter for 73877-03 Flowmeter |
| 73864-98 | Transmitter for 73877-08 Flowmeter |
| 76016 | Flowmeter Transmitter for 75914 Flowmeter |
| 76017 | Fiber Optic Receiver |
| 73867-25 | Interface Cable Assembly, 25 ft. |
| 73867-75 | Interface Cable Assembly, 75 ft. |
| 73867-100 | Interface Cable Assembly, 100 ft. |
| 73867-120 | Interface Cable Assembly, 120 ft. |
| 76061-01 | Interface Cable, Discrete I/O to Bus Board, 5 ft. Length |
| 76061-02 | Interface Cable, Discrete I/O to Bus Board, 10 ft. Length |
| 76061-03 | Interface Cable, Discrete I/O to Bus Board, 15 ft. Length |
| 76061-04 | Interface Cable, Discrete I/O to Bus Board, 20 ft. Length |
| A10216-01 | AdaptaFlow 5000 Bus Board |
| A10217-01 | AdaptaFlow 5000 Power Supply Module |
| A10218-01 | AdaptaFlow 5000 Channel Card |
| A10159-01 | AdaptaFlow 5000 Node Adapter Module |
| 75588-01 | AdaptaFlow 5000 Node Adapter Interface Board |
| 76400 | Display/Control Unit |

Replacement or spare parts are available from ITW Ransburg. Contact your ITW Ransburg representative for availability and ordering information.

NOTES:

WARRANTY POLICIES

LIMITED WARRANTY

ITW Ransburg will replace or repair without charge any part and/or equipment that falls within the specified time (see below) because of faulty workmanship or material, provided that the equipment has been used and maintained in accordance with ITW Ransburg's written safety and operating instructions, and has been used under normal operating conditions. Normal wear items are excluded.

THE USE OF OTHER THAN ITW RANSBURG APPROVED PARTS, VOID ALL WARRANTIES.

SPARE PARTS: One hundred and eighty (180) days from date of purchase, except for rebuilt parts (any part number ending in "R") for which the warranty period is ninety (90) days.

EQUIPMENT: When purchased as a complete unit, (i.e., guns, power supplies, control units, etc.), is one (1) year from date of purchase.

WRAPPING THE APPLICATOR IN PLASTIC, SHRINK-WRAP, ETC., WILL VOID THIS WARRANTY.

FLUID HANDLING: One (1) year from date of purchase (i.e., Totalizer, CCV Valves, etc.).

AIR BEARING ROTATORS: Fifteen thousand (15,000) hours or three (3) years, whichever occurs first. Warranty period begins on the date of purchase.

ITW RANSBURG'S ONLY OBLIGATION UNDER THIS WARRANTY IS TO REPLACE PARTS THAT HAVE FAILED BECAUSE OF FAULTY WORKMANSHIP OR MATERIALS. THERE ARE NO IMPLIED WARRANTIES NOR WARRANTIES OF EITHER MERCHANTABILITY OR FITNESS FOR A PARTICULAR PURPOSE. ITW RANSBURG ASSUMES NO LIABILITY FOR INJURY, DAMAGE TO PROPERTY OR FOR CONSEQUENTIAL DAMAGES FOR LOSS OF GOODWILL OR PRODUCTION OR INCOME, WHICH RESULT FROM USE OR MISUSE OF THE EQUIPMENT BY PURCHASER OR OTHERS.

EXCLUSIONS:

If, in ITW Ransburg's opinion the warranty item in question, or other items damaged by this part was improperly installed, operated or maintained, ITW Ransburg will assume no responsibility for repair or replacement of the item or items. The purchaser, therefore will assume all responsibility for any cost of repair or replacement and service related costs if applicable.

APPENDIX

PAINT AND SOLVENT SPECIFICATIONS

| | REA™ / EFM™ EVOLVER | REM™ / M90™ | NO. 2 HAND GUN | TURBODISK™ | AEROBELL® II*** AEROBELL® AEROBELL® 33 RMA™-101 |
|--|------------------------|--------------|----------------|--------------|--|
| RECOMMENDED VISCOSITY USING A ZAHN NO. 2 | 18 TO 30 SEC | 18 TO 30 SEC | 20 TO 60 SEC | 20 TO 60 SEC | 20 TO 60 SEC |
| PAINT ELECTRICAL RESISTANCE** | .1 MΩ TO ∞ | .1 MΩ TO ∞ | .1 TO 1 MΩ | .1 MΩ TO ∞ | .1 MΩ TO ∞ |
| RECOMMENDED DELIVERY (UP TO) | 1000 cc/min | 1500 cc/min | 180 cc/min | 1000 cc/min | 500 cc/min |

GUIDE TO USABLE SOLVENT SELECTION

| Chemical Name | Common Name | Category | Flash Point†† (TCC) | *CAS Number | Evap. Rate† | Elec. Res.** |
|------------------------|--------------------|------------------------|---------------------|-----------------|-------------|--------------|
| DICHLOROMETHANE | Methylene Chloride | Chlorinated Solvents | | 75-09-2 | 14.5 | HIGH |
| VM & P NAPHTHA | Naptha | Aliphatic Hydrocarbons | 65°F | 8030-30-6 | 10 | HIGH |
| ACETONE | | Ketones | -18°F | 67-64-1 | 5.6 | LOW |
| METHYL ACETATE | | Esters | 90°F | 79-20-9 | 5.3 | LOW |
| BENZENE | | Aromatic Hydrocarbons | 12°F | 71-43-2 | 5.1 | HIGH |
| ETHYL ACETATE | | Esters | 24°F | 141-78-6 | 3.9 | MEDIUM |
| 2-BUTANONE | MEK | Ketones | 16°F | 78-93-3 | 3.8 | MEDIUM |
| ISO-PROPYL ACETATE | | Esters | 35°F | 108-21-4 | 3.4 | LOW |
| ISOPROPYL ALCOHOL | IPA | Alcohols | 53°F | 67-63-0 | 2.5 | LOW |
| 2-PENTANONE | MPK | Ketones | 104°F | 107-87-9 | 2.5 | MEDIUM |
| METHANOL | Methyl Alcohol | Alcohols | 50°F | 67-56-1 | 2.1 | LOW |
| PROPYL ACETATE | n-Propyl Acetate | Esters | 55°F | 109-60-4 | 2.1 | LOW |
| TOLUOL | Toluene | Aromatic Hydrocarbons | 48°F | 108-88-3 | 1.9 | HIGH |
| METHYL ISOBUTYL KETONE | MIBK | Ketones | 60°F | 108-10-1 | 1.6 | MEDIUM |
| ISOBUTYLACETATE | | Esters | 69°F | 110-19-0 | 1.5 | LOW |
| ETHANOL | Ethyl Alcohol | Alcohols | | 64-17-5 | 1.4 | LOW |
| BUTYL ACETATE | | Esters | 78°F | 123-86-4 | 1.0 | LOW |
| ETHYLBENZENE | | Aromatic Hydrocarbons | 64°F | 100-41-4 | .89 | HIGH |
| 1-PROPANOL | n-Propyl Alcohol | Alcohols | 74°F | 71-23-8 | .86 | LOW |
| 2-BUTANOL | sec.-Butyl Alcohol | Alcohols | 72°F | 78-92-2 | .81 | LOW |
| XYLOL | Xylene | Aromatic Hydrocarbons | 79°F | 1330-02-07 | .80 | HIGH |
| AMYLACETATE | | Esters | 106°F | 628-63-7 | .67 | MEDIUM |
| 2-METHYLPROPANOL | iso-Butyl Alcohol | Alcohols | 82°F | 78-83-1 | .62 | LOW |
| METHYL AMYL ACETATE | | Esters | 96°F | 108-84-9 | .50 | LOW |
| 5-METHYL-2-HEXANONE | MIAK | Ketones | 96°F | 110-12-3 | .50 | MEDIUM |
| 1-BUTANOL | n-Butyl Alcohol | Alcohols | 95°F | 71-36-3 | .43 | LOW |
| 2-ETHOXYETHANOL | | Glycol Ethers | 164°F | 110-80-5 | .38 | LOW |
| 2-HEPTANONE | MAK | Ketones | 102°F | 110-43-0 | .40 | MEDIUM |
| CYCLOHEXANONE | | Ketones | 111°F | 108-94-1 | .29 | MEDIUM |
| AROMATIC-100 | SC#100 | Aromatic Hydrocarbons | 111°F | | .20 | HIGH |
| DIISOBUTYL KETONE | DIBK | Ketones | 120°F | 108-83-8 | .19 | MEDIUM |
| 1-PENTANOL | Amyl Alcohol | Alcohols | | 71-41-0 | .15 | LOW |
| DIACETONE ALCOHOL | | Ketones | 133°F | 123-42-2 | .12 | LOW |
| 2-BUTOXYETHANOL | Butyl Cellosolve | Glycol Ethers | 154°F | 111-76-2 | .07 | LOW |
| CYCLOHEXANOL | | Alcohols | 111°F | 108-93-0 | .05 | LOW |
| AROMATIC-150 | SC#150 | Aromatic Hydrocarbons | 149°F | | .004 | HIGH |
| AROMATIC-200 | | Aromatic Hydrocarbons | 203°F | | .003 | HIGH |

* CAS Number: Chemical Abstract Service Number.

© 05/2004 Illinois Tool Works Inc. All rights reserved.

** Electrical Resistance using the ITW Ransburg Meter.

*** Solvent Base Configuration Only.

† Information Obtained From: <http://solvdb.ncms.org>

†† The lowest temperature at which a volatile fluid will ignite.

Evaporation Rate is Based Upon Butyl Acetate Having a Rate of 1.0

NOTE: Chart provides resistance and control information that we feel is necessary when using ITW Ransburg equipment.

| VISCOSITY CONVERSION CHART | | | | | | | | | | | | | | | | | | |
|----------------------------|------------|-----------------|------------------|----------|----------|------------|------------|------------------------|------------------------|---------------|-----------------------|--------|--------|--------|--------|--------|---------------------|-----------|
| Poise | Centipoise | DuPont Parlin 7 | DuPont Parlin 10 | Fisher 1 | Fisher 2 | Ford Cup 3 | Ford Cup 4 | Gardner - Holdt Bubble | Gardner - Lithographic | Krebs Unit KU | Saybolt Universal SSU | Zahn 1 | Zahn 2 | Zahn 3 | Zahn 4 | Zahn 5 | Sears Craftsman Cup | Din Cup 4 |
| .1 | 10 | 27 | 11 | 20 | | | 5 | A-4 | | | 60 | 30 | 16 | | | | | 10 |
| .15 | 15 | 30 | 12 | 25 | | | 8 | A-3 | | | 80 | 34 | 17 | | | | | 11 |
| .2 | 20 | 32 | 13 | 30 | 15 | 12 | 10 | | | | 100 | 37 | 18 | | | | | 12 |
| .25 | 25 | 37 | 14 | 35 | 17 | 15 | 12 | A-2 | | | 130 | 41 | 19 | | | | | 13 |
| .3 | 30 | 43 | 15 | 39 | 18 | 19 | 14 | A-1 | | | 160 | 44 | 20 | | | | | 14 |
| .4 | 40 | 50 | 16 | 50 | 21 | 25 | 18 | A | | | 210 | 52 | 22 | | | | 19 | 15 |
| .5 | 50 | 57 | 17 | | 24 | 29 | 22 | | | 30 | 260 | 60 | 24 | | | | 20 | 16 |
| .6 | 60 | 64 | 18 | | 29 | 33 | 25 | B | | 33 | 320 | 68 | 27 | | | | 21 | 18 |
| .7 | 70 | | 20 | | 33 | 36 | 28 | | | 35 | 370 | | 30 | | | | 23 | 21 |
| .8 | 80 | | 22 | | 39 | 41 | 31 | C | | 37 | 430 | | 34 | | | | 24 | 23 |
| .9 | 90 | | 23 | | 44 | 45 | 32 | | | 38 | 480 | | 37 | 10 | | | 26 | 25 |
| 1.0 | 100 | | 25 | | 50 | 50 | 34 | D | | 40 | 530 | | 41 | 12 | 10 | | 27 | 27 |
| 1.2 | 120 | | 30 | | 62 | 58 | 41 | E | | 43 | 580 | | 49 | 14 | 11 | | 31 | 31 |
| 1.4 | 140 | | 32 | | | 66 | 45 | F | | 46 | 690 | | 58 | 16 | 13 | | 34 | 34 |
| 1.6 | 160 | | 37 | | | | 50 | G | | 48 | 790 | | 66 | 18 | 14 | | 38 | 38 |
| 1.8 | 180 | | 41 | | | | 54 | | 000 | 50 | 900 | | 74 | 20 | 16 | | 40 | 43 |
| 2.0 | 200 | | 45 | | | | 58 | H | | 52 | 1000 | | 82 | 23 | 17 | 10 | 44 | 46 |
| 2.2 | 220 | | | | | | 62 | I | | 54 | 1100 | | | 25 | 18 | 11 | | 51 |
| 2.4 | 240 | | | | | | 65 | J | | 56 | 1200 | | | 27 | 20 | 12 | | 55 |
| 2.6 | 260 | | | | | | 68 | | | 58 | 1280 | | | 30 | 21 | 13 | | 58 |
| 2.8 | 280 | | | | | | 70 | K | | 59 | 1380 | | | 32 | 22 | 14 | | 63 |
| 3.0 | 300 | | | | | | 74 | L | | 60 | 1475 | | | 34 | 24 | 15 | | 68 |
| 3.2 | 320 | | | | | | | M | | | 1530 | | | 36 | 25 | 16 | | 72 |
| 3.4 | 340 | | | | | | | N | | | 1630 | | | 39 | 26 | 17 | | 76 |
| 3.6 | 360 | | | | | | | O | | 62 | 1730 | | | 41 | 28 | 18 | | 82 |
| 3.8 | 380 | | | | | | | | | | 1850 | | | 43 | 29 | 19 | | 86 |
| 4.0 | 400 | | | | | | | P | | 64 | 1950 | | | 46 | 30 | 20 | | 90 |
| 4.2 | 420 | | | | | | | | | | 2050 | | | 48 | 32 | 21 | | 95 |
| 4.4 | 440 | | | | | | | Q | | | 2160 | | | 50 | 33 | 22 | | 100 |
| 4.6 | 460 | | | | | | | R | | 66 | 2270 | | | 52 | 34 | 23 | | 104 |
| 4.8 | 480 | | | | | | | | 00 | 67 | 2380 | | | 54 | 36 | 24 | | 109 |
| 5.0 | 500 | | | | | | | S | | 68 | 2480 | | | 57 | 37 | 25 | | 112 |
| 5.5 | 550 | | | | | | | T | | 69 | 2660 | | | 63 | 40 | 27 | | 124 |
| 6.0 | 600 | | | | | | | U | | 71 | 2900 | | | 68 | 44 | 30 | | 135 |
| 7.0 | 700 | | | | | | | | | 74 | 3375 | | | | 51 | 35 | | 160 |
| 8.0 | 800 | | | | | | | | 0 | 77 | 3380 | | | | 58 | 40 | | 172 |
| 9.0 | 900 | | | | | | | V | | 81 | 4300 | | | | 64 | 45 | | 195 |
| 10.0 | 1000 | | | | | | | W | | 85 | 4600 | | | | | 49 | | 218 |
| 11.0 | 1100 | | | | | | | | | 88 | 5200 | | | | | 55 | | |
| 12.0 | 1200 | | | | | | | | | 92 | 5620 | | | | | 59 | | |

| VISCOSITY CONVERSION CHART (Continued) | | | | | | | | | | | | | | | | | | |
|---|------------|--------------------|---------------------|----------|----------|------------|------------|---------------------------|---------------------------|------------------|--------------------------|--------|--------|--------|--------|--------|------------------------|-----------|
| Poise | Centipoise | DuPont Parlin 7 | DuPont Parlin 10 | Fisher 1 | Fisher 2 | Ford Cup 3 | Ford Cup 4 | Gardner - Holdt Bubble | Gardner - Lithographic | Krebs Unit KU | Saybolt Universal SSU | Zahn 1 | Zahn 2 | Zahn 3 | Zahn 4 | Zahn 5 | Sears Craftsman Cup | Din Cup 4 |
| 13.0 | 1300 | | | | | | | X | | 95 | 6100 | | | | | 64 | | |
| 14.0 | 1400 | | | | | | | | 1 | 96 | 6480 | | | | | | | |
| 15.0 | 1500 | | | | | | | | | 98 | 7000 | | | | | | | |
| 16.0 | 1600 | | | | | | | | | 100 | 7500 | | | | | | | |
| 17.0 | 1700 | | | | | | | | | 101 | 8000 | | | | | | | |
| 18.0 | 1800 | | | | | | | Y | | | 8500 | | | | | | | |
| 19.0 | 1900 | | | | | | | | | | 9000 | | | | | | | |
| 20.0 | 2000 | | | | | | | | | 103 | 9400 | | | | | | | |
| 21.0 | 2100 | | | | | | | | | | 9850 | | | | | | | |
| 22.0 | 2200 | | | | | | | | | | 10300 | | | | | | | |
| 23.0 | 2300 | | | | | | | Z | 2 | 105 | 10750 | | | | | | | |
| 24.0 | 2400 | | | | | | | | | 109 | 11200 | | | | | | | |
| 25.0 | 2500 | | | | | | | Z-1 | | 114 | 11600 | | | | | | | |
| 30.0 | 3000 | | | | | | | | | 121 | 14500 | | | | | | | |
| 35.0 | 3500 | | | | | | | Z-2 | 3 | 129 | 16500 | | | | | | | |
| 40.0 | 4000 | | | | | | | | | 133 | 18500 | | | | | | | |
| 45.0 | 4500 | | | | | | | Z-3 | | 136 | 21000 | | | | | | | |
| 50.0 | 5000 | | | | | | | | | | 23500 | | | | | | | |
| 55.0 | 5500 | | | | | | | | | | 26000 | | | | | | | |
| 60.0 | 6000 | | | | | | | Z-4 | 4 | | 2800 | | | | | | | |
| 65.0 | 6500 | | | | | | | | | | 30000 | | | | | | | |
| 70.0 | 7000 | | | | | | | | | | 32500 | | | | | | | |
| 75.0 | 7500 | | | | | | | | | | 35000 | | | | | | | |
| 80.0 | 8000 | | | | | | | | | | 37000 | | | | | | | |
| 85.0 | 8500 | | | | | | | | | | 39500 | | | | | | | |
| 90.0 | 9000 | | | | | | | | | | 41000 | | | | | | | |
| 95.0 | 9500 | | | | | | | | | | 43000 | | | | | | | |
| 100.0 | 10000 | | | | | | | Z-5 | 5 | | 46500 | | | | | | | |
| 110.0 | 11000 | | | | | | | | | | 51000 | | | | | | | |
| 120.0 | 12000 | | | | | | | | | | 55005 | | | | | | | |
| 130.0 | 13000 | | | | | | | | | | 60000 | | | | | | | |
| 140.0 | 14000 | | | | | | | | | | 65000 | | | | | | | |
| 150.0 | 15000 | | | | | | | Z-6 | | | 67500 | | | | | | | |
| 160.0 | 16000 | | | | | | | | | | 74000 | | | | | | | |
| 170.0 | 17000 | | | | | | | | | | 83500 | | | | | | | |
| 180.0 | 18000 | | | | | | | | | | 83500 | | | | | | | |
| 190.0 | 19000 | | | | | | | | | | 88000 | | | | | | | |
| 200.0 | 20000 | | | | | | | | | | 93000 | | | | | | | |
| 300.0 | 30000 | | | | | | | | | | 140000 | | | | | | | |

Note: All viscosity comparisons are as accurate as possible with existing information. Comparisons are made with a material having a specific gravity of 1.0.

| VOLUMETRIC CONTENT OF HOSE OR TUBE (English Units) | | | | | | | |
|---|--------|---|--------------------------|---------------------------|---------------------------|---------------------------|---------------------------|
| I.D. (inches) | cc/ft. | Cross Section (in. ²) | Length | | | | |
| | | | 5ft. (60") | 10ft. (120") | 15ft. (180") | 25ft. (300") | 50ft. (600") |
| 1/8 | 2.4 | .012 | .003 gal. .4 fl. oz. | .006 gal. .8 fl. oz. | .010 gal. 1.2 fl. oz. | .016 gal. 2.0 fl. oz. | .032 gal. 4.1 fl. oz. |
| 3/16 | 5.4 | .028 | .007 gal. .9 fl. oz. | .014 gal. 1.8 fl. oz. | .022 gal. 2.8 fl. oz. | .036 gal. 4.6 fl. oz. | .072 gal. 9.2 fl. oz. |
| 1/4 | 9.7 | .049 | .013 gal. 1.6 fl. oz. | .025 gal. 3.3 fl. oz. | .038 gal. 4.9 fl. oz. | .064 gal. 8.2 fl. oz. | .127 gal. 16.3 fl. oz. |
| 5/16 | 15.1 | .077 | .020 gal. 2.5 fl. oz. | .040 gal. 5.1 fl. oz. | .060 gal. 7.6 fl. oz. | .100 gal. 12.7 fl. oz. | .199 gal. 25.5 fl. oz. |
| 3/8 | 21.7 | .110 | .029 gal. 3.7 fl. oz. | .057 gal. 7.3 fl. oz. | .086 gal. 11.0 fl. oz. | .143 gal. 18.4 fl. oz. | .287 gal. 36.7 fl. oz. |
| 1/2 | 38.6 | .196 | .051 gal. 6.5 fl. oz. | .102 gal. 13.1 fl. oz. | .153 gal. 19.6 fl. oz. | .255 gal. 32.6 fl. oz. | .510 gal. 65.3 fl. oz. |

| VOLUMETRIC CONTENT OF HOSE OR TUBE (Metric Units) | | | | | | | |
|--|------|--|---------|----------|----------|----------|----------|
| I.D. (mm) | cc/m | Cross Section (mm ²) | Length | | | | |
| | | | 1.5m | 3.0m | 4.5m | 6.0m | 7.5m |
| 3.6 | 10.2 | 10.2 | 15.3 cc | 30.5 cc | 45.8 cc | 61.1 cc | 76.3 cc |
| 5.6 | 24.6 | 24.6 | 36.9 cc | 73.9 cc | 110.8 cc | 147.8 cc | 184.7 cc |
| 6.8 | 36.3 | 36.3 | 54.5 cc | 109.0 cc | 163.4 cc | 217.9 cc | 272.4 cc |
| 8.8 | 60.8 | 60.8 | 91.2 cc | 182.5 cc | 273.7 cc | 364.9 cc | 456.2 cc |

© 05/2004 Illinois Tool Works Inc. All rights reserved.

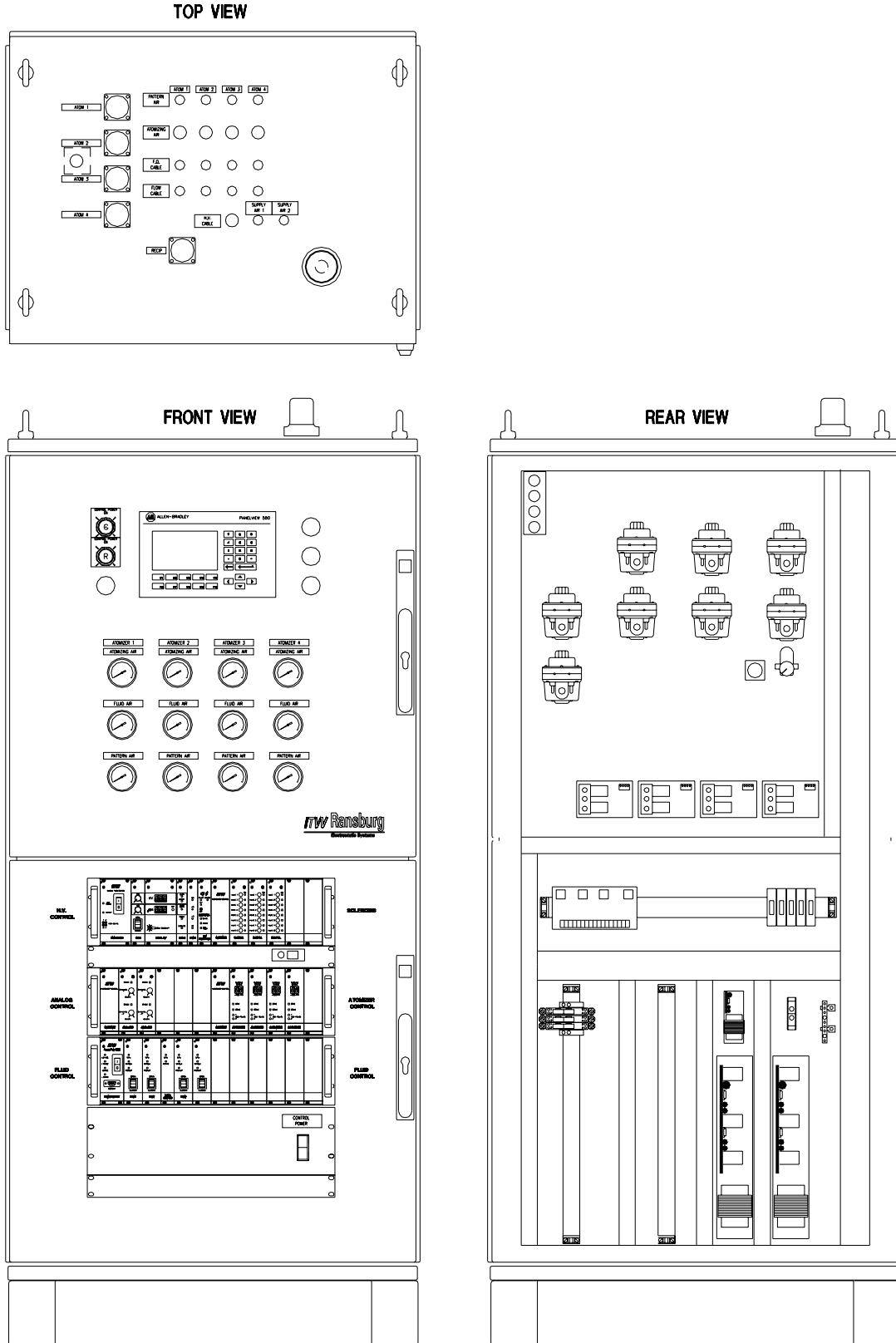

Figure 56: Typical System Control Panel

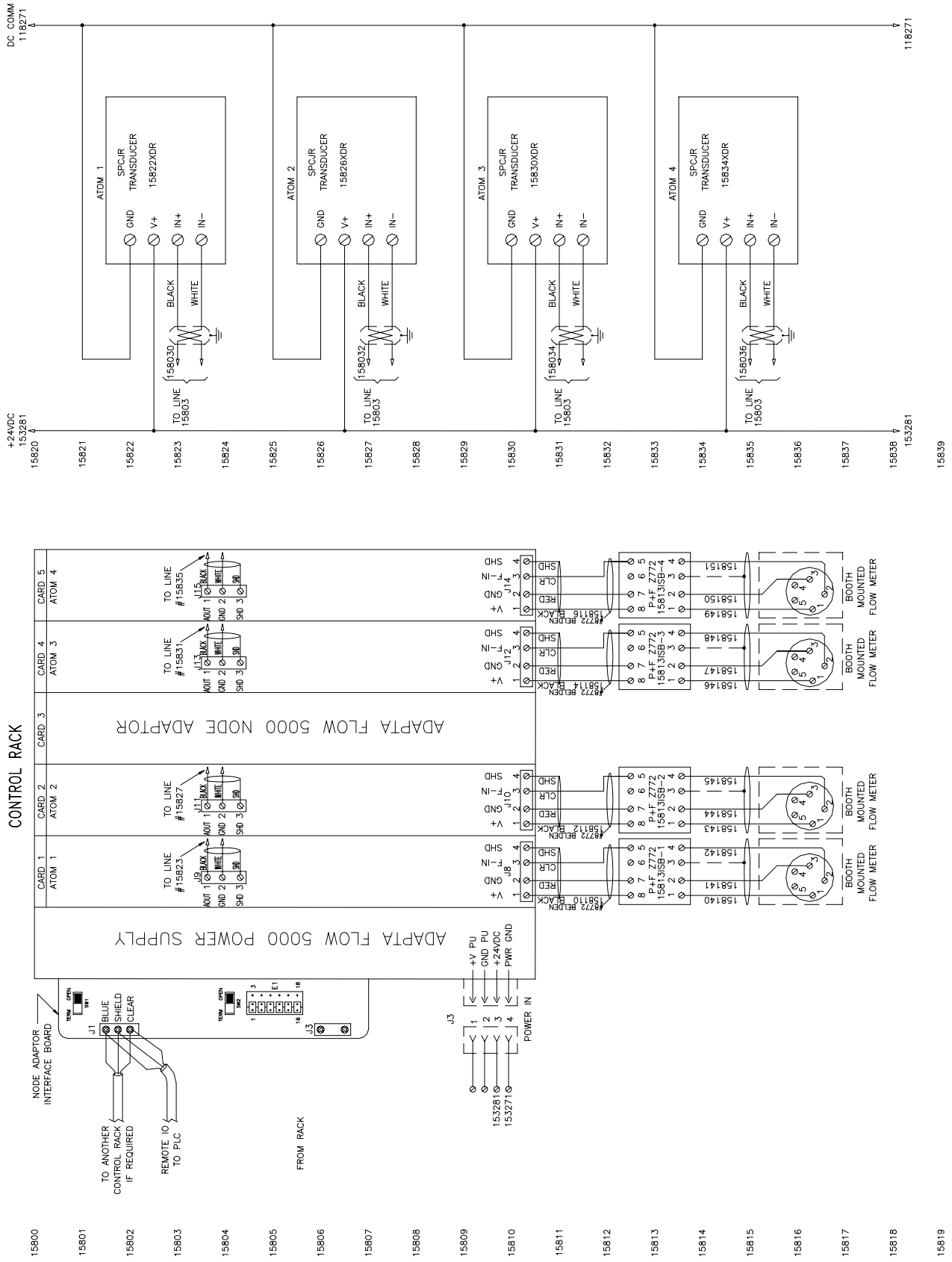

Figure 57: Control System Schematic

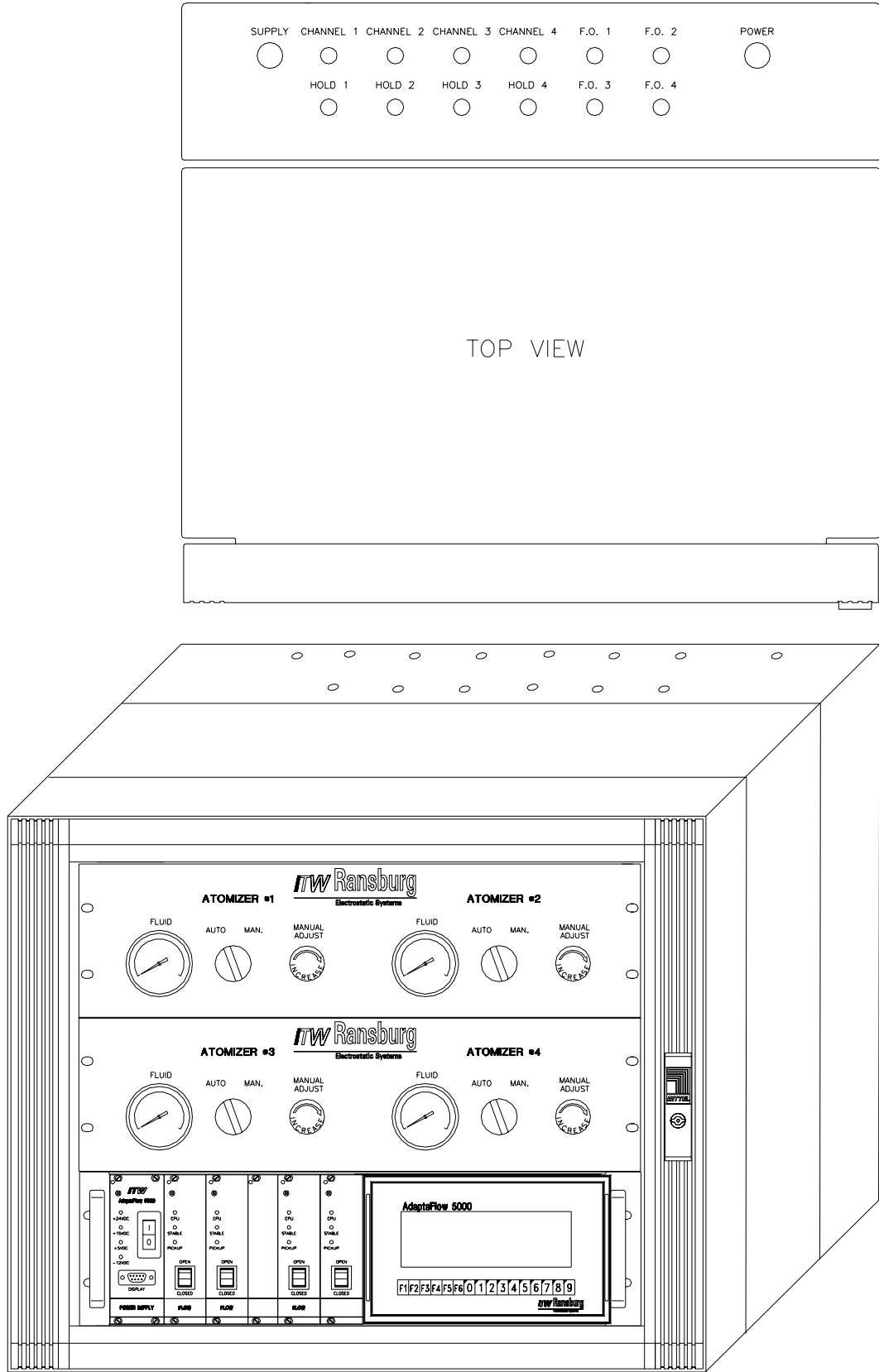

Figure 58: Stand-Alone Control Panel

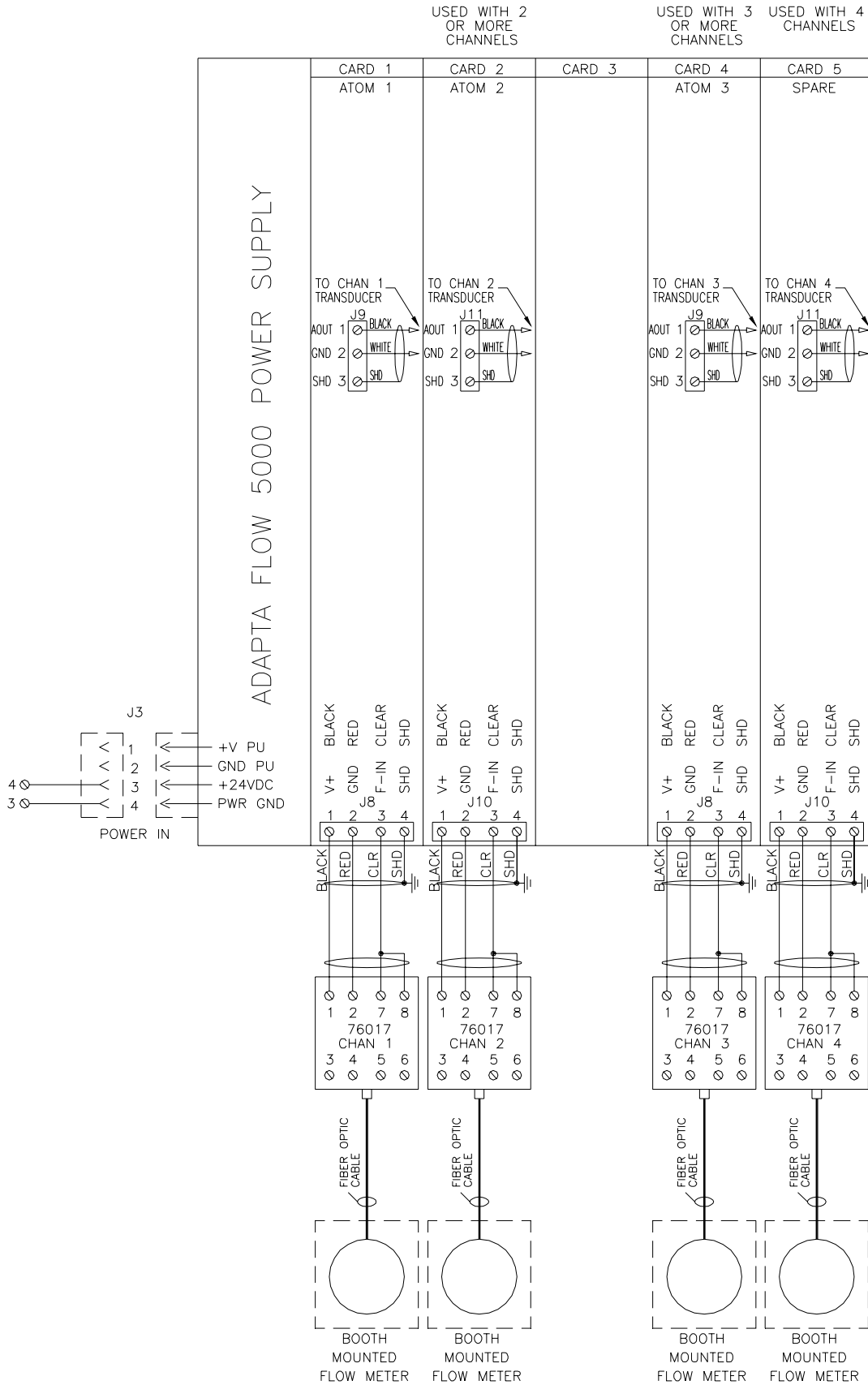

Figure 59: Electrical Schematic, Fiber Optic System

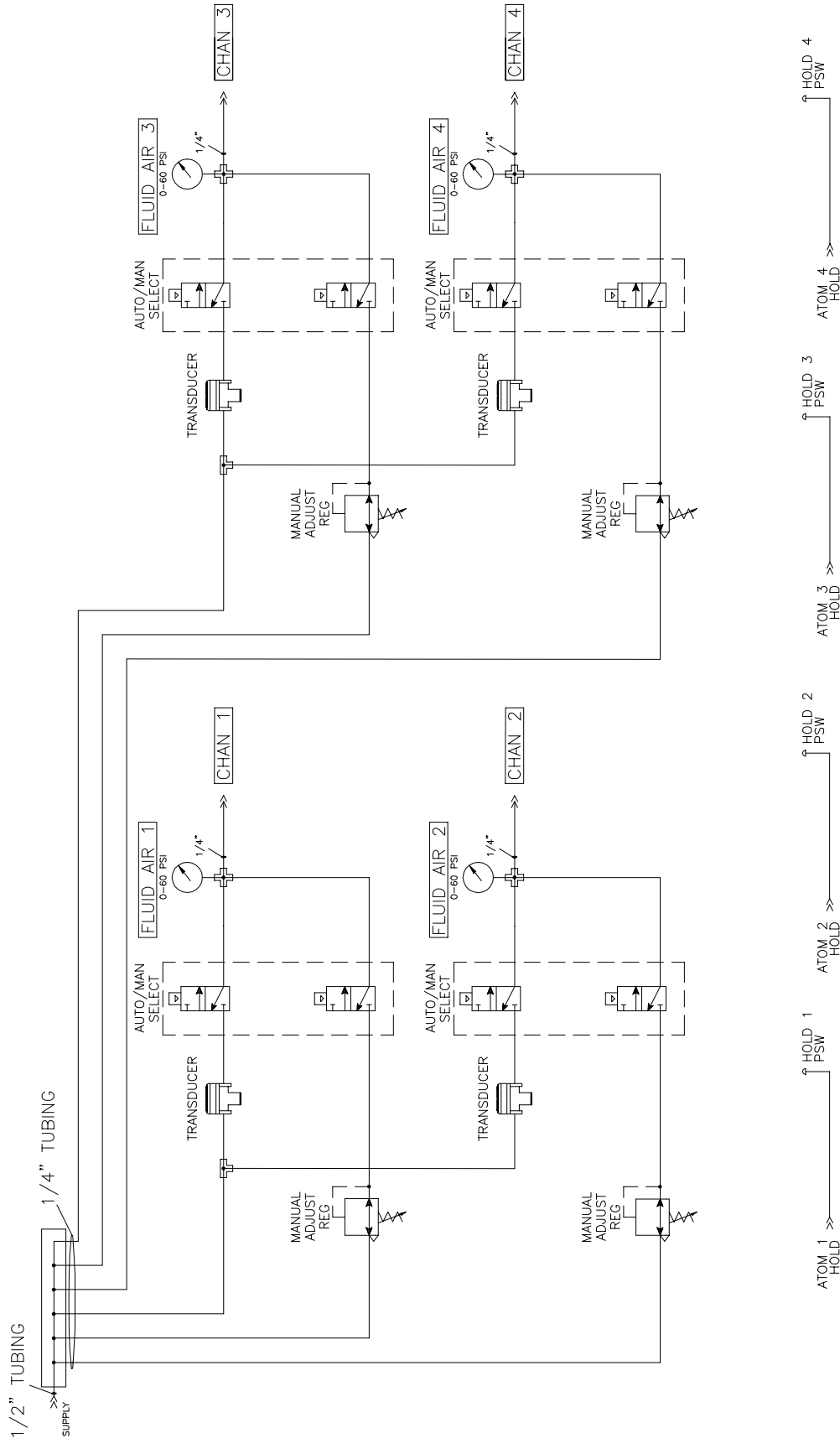

Figure 60: Pneumatic Schematic, Stand-Alone Unit

FIGURE 17: PNEUMATIC SCHEMATIC, STAND ALONE UNIT

SERIAL PROGRAMMING COMMAND REFERENCE

The following table describes each of the Channel Card variables with the information necessary for control communication through the RS-232 serial port. This information is necessary when controlling the AdaptaFlow Channel Cards with a controller other than the 76400 or Allen-Bradley PLC/Node Adapter combination.

These variables are described further in the **Variable Definitions** section.

| CHANNEL CARD PROGRAM COMMAND TABLE (Figure 61) | | | | | |
|---|-------|------------------|-------|-------------|--|
| ASCII Command# | | Total # of Bytes | | Color Table | Description |
| Read | Write | Read | Write | | |
| 100 | 500 | 12 | 9 | | Flow Rate Mellow with Engineering Units Attached |
| 101 | 501 | 12 | 9 | | Totalizer with Engineering Units Attached |
| 102 | 502 | 9 | 9 | | Active Set Value for PID (Analog In is overriding if greater than the Analog Input Offset) |
| 103 | 503 | 9 | 9 | | Digital Set Value for PID (Sets requested flow rate if an external analog input is not used) |
| 104 | 504 | 9 | 9 | | Sample Amount (For flow rate mellow) |
| 105 | 505 | 9 | 9 | | Analog Control Output Gain to transducer |
| 106 | 506 | 9 | 9 | | KFR with Decimal Point |
| 107 | 507 | 9 | 9 | | KFT with Decimal Point |
| 108 | 508 | 9 | 9 | | Death Delay - Delay time to be applied after table pick |
| 109 | 509 | 3 | 3 | | Rate Display Engineering Units for KFR (CCM, LPM, GPM, etc.) |
| 110 | 510 | 3 | 3 | | Total Display Engineering Units for KFT (CC, GAL, etc.) |
| 111 | 511 | 9 | 9 | | Analog Control Output Offset to the transducer |
| 112 | 512 | 9 | 9 | Yes | PID Tolerance |
| 113 | 513 | 9 | 9 | Yes | PID Proportional |
| 114 | 514 | 9 | 9 | | PID Derivative |
| 115 | 515 | 9 | 9 | | PID Integral |
| 116 | 516 | 9 | 9 | | Analog Output Gain - Voltage Out at Analog Control Output. Represents Actual Flow When in Monitor Mode. |
| 117 | 517 | 9 | 9 | | PID Delta Step for Table Correction |
| 118 | 518 | 9 | 9 | | Operating Mode 1 = Monitor Mode 2 = Hard Wired Mode 3 = Node Adapter Mode |
| 119 | 519 | 9 | 9 | | Cutoff Frequency for Rate |
| 120 | 520 | 9 | 9 | | Analog Output Offset for Value Determined by Analog Output Pointer and Analog Output Shifter. |
| 121 | 521 | 9 | 9 | | Transparent A (User Programmable Analog Output Voltage to the Transducer) |

Figure 61: Channel Card Program Command Table

| CHANNEL CARD PROGRAM COMMAND TABLE (Figure 61) | | | | | |
|---|--------------|-------------------------|--------------|--------------------|---|
| ASCII Command# | | Total # of Bytes | | Color Table | Description |
| Read | Write | Read | Write | | |
| 122 | 522 | 9 | 9 | | Transparent B (User Programmable Analog Output Voltage) |
| 123 | 523 | 9 | 9 | Yes | PID Initial Kick |
| 126 | 526 | 9 | 9 | | Set Value Analog Input Gain |
| 127 | 527 | 9 | 9 | | Analog Out Gain for Value Determined by Analog Output Pointer and Analog Output Shifter. |
| 128 | 528 | 3 | 3 | | Version Number |
| 129 | 529 | 12 | 9 | | Grand Totalizer with Engineering Units |
| 130 | 530 | 12 | 9 | | Flow Rate Instantaneous with Engineering Units |
| 132 | 532 | 9 | 9 | | Analog Output Pointer |
| 134 | 534 | 9 | 9 | | Analog Output Shifter |
| 135 | 535 | 9 | 9 | | Analog Output Gain |
| 138 | 538 | 9 | 9 | | Linearizer Mode (00=None, 01=Channel A, 02=Channel 2, 03=Both) |
| 139 | 539 | 9 | 9 | | Channel Offset (0-252, 0=Default) |
| 140 | 540 | 9 | 9 | | Color Number Entered (If this is 255, then Analog In is Overriding) |
| 250 | 650 | 9 | 9 | | Total Limit 1 |
| 251 | 651 | 9 | 9 | | Total Limit 2 |
| 252 | 652 | 9 | 9 | | Total Limit 3 |
| 253 | 653 | 9 | 9 | | Total Limit 4 |
| 254 | 654 | 9 | 9 | | Flow Rate Limit 1 |
| 255 | 655 | 9 | 9 | | Flow Rate Limit 2 |
| 256 | 656 | 9 | 9 | | Flow Rate Limit 3 |
| 257 | 657 | 9 | 9 | | Flow Rate Limit 4 |
| 262 | 662 | 9 | 9 | | Limit Rule 1 |
| 263 | 663 | 9 | 9 | | Limit Rule 2 |
| 264 | 664 | 9 | 9 | | Limit Rule 3 |
| 265 | 665 | 9 | 9 | | Limit Rule 4 |
| 266 | 666 | 9 | 9 | | Margin for Rate 1 |
| 267 | 667 | 9 | 9 | | Margin for Rate 2 |
| 268 | 668 | 9 | 9 | | Margin for Rate 3 |
| 269 | 669 | 9 | 9 | | Margin for Rate 4 |
| 400 | | 100 | | Yes | Read Table for Set Values (1-10) |
| 401 | | 50 | | Yes | Read Table for Analog Output Values (1-10) |
| 403 | | 9 | | | Actual Analog Out |
| 406 | | 9 | | | Actual Analog In |
| 407 | | 9 | | | PID Error |
| 408 | | 9 | | | PID Input Status |
| 409 | | 9 | | | Limit Status for Limit Outputs |
| 411 | | 100 | | | Read Linearizer Table for Correction Frequencies. Example: 0000100.0/..... |
| 412 | | 80 | | | Read Correction Percentages with Sign. Example: +001.00/-010.22/..... |
| 413 | | 9 | | | Read Color Number (0-32) |

Figure 61 (Continued): Channel Card Program Command Table

| CHANNEL CARD PROGRAM COMMAND TABLE (Figure 61) | | | | | |
|---|-------|------------------|-------|-------------|--|
| ASCII Command# | | Total # of Bytes | | Color Table | Description |
| Read | Write | Read | Write | | |
| | | | | | WARNING: THE FOLLOWING ARE SPECIAL WRITE OPERATIONS THAT CAN CREATE DANGEROUS CONDITIONS. BE CAREFUL! |
| | 450 | | 24... | | Frequency Correction Percentage for One Point |
| | 451 | | | | Correction Percentage for One Point |
| | 452 | | 10 | | Force a Channel Number On for One Card (REMEMBER, ONLY ONE) |
| | 453 | | 7 | | Force a Reset on Next Power Up |
| | 454 | | 10 | | Force Zero's into Specific Color Table |

Figure 61 (Continued): Channel Card Program Command Table

MANUAL CHANGE SUMMARY

This manual was published to replace Service Manual **LN-9219-00.1**, *AdaptaFlow 5000*, to make the following changes:

1. New drawing on front cover.
2. Addition of "Warning" to prevent channel module damage.
3. Addition of troubleshooting information for resetting RAM.
4. Clarified operation of diagnostic functions using 76400 unit.
5. Revised "Troubleshooting Guide" table structure.
6. Updated "Warranty Policies" section.
7. Added "ITW Ransburg Paint and Solvent Specifications" chart.
8. Updated/corrected "ITW Ransburg Viscosity Conversion Chart".
9. Added metric conversion to the "Volumetric Content of Hose or Tube" chart.

Manufacturing

1910 North Wayne Street
Angola, Indiana 46703-9100
Telephone: 260/665-8800
Fax: 260/665-8516

Technical/Service Assistance

Automotive Assembly and Tier I
Industrial Systems
Ransburg Guns

Telephone: 800/ 626-3565 Fax: 419/ 470-2040
Telephone: 800/ 233-3366 Fax: 419/ 470-2071
Telephone: 800/ 233-3366 Fax: 419/ 470-2071

Technical Support Representative will direct you to the appropriate telephone number for ordering Spare Parts.

