

---

## RF 1 FIBER OPTIC FLOW METER HIGH AND LOW PRESSURE

---

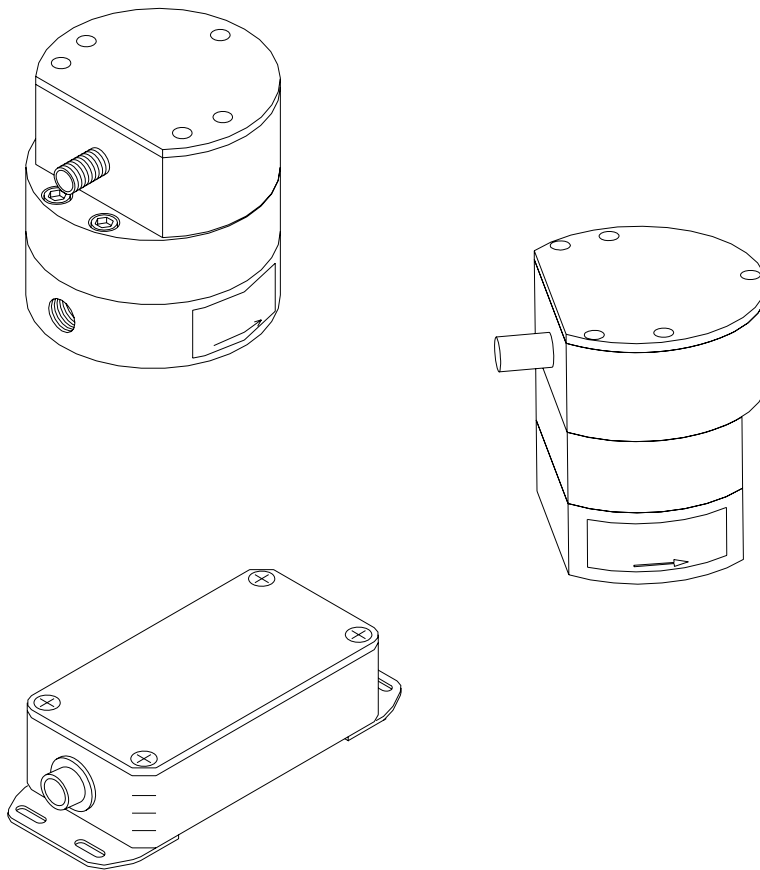

**MODELS: 77786-XX, A11516-XX**

---



**IMPORTANT:** Before using this equipment, carefully read **SAFETY PRECAUTIONS**, starting on page 1, and all instructions in this manual. Keep this Service Manual for future reference.

Service Manual Price: \$20.00 (U.S.)

**NOTE:** This manual has been changed from **FM-00-02.4** to revision **FM-00-02.5**. Reasons for this change are noted under “Manual Change Summary” inside the back cover of this manual.

---

# CONTENTS

---

	<b>PAGE</b>
<b>SAFETY:</b>	<b>1-4</b>
SAFETY PRECAUTIONS.....	1
HAZARDS / SAFEGUARDS.....	2-4
<b>INTRODUCTION:</b>	<b>6-10</b>
THEORY OF OPERATION.....	6
TRANSMITTER.....	6-7
RECEIVER.....	7
FIBER OPTIC CABLING.....	7
HANDLING AND STORAGE PRECAUTIONS.....	7-8
FLOW RATE ACCURACY.....	8
REVERSE FLOW DETECTION.....	8
FLUID PASSAGES.....	8
MOUNTING LOCATION FOR THE TRANSMITTER.....	8
SPECIFICATIONS.....	9-10
<b>INSTALLATION:</b>	<b>11-17</b>
VIEW OF FLOW METER BODIES.....	11
INSTALLATION LOCATIONS FOR TRANSMITTER AND RECEIVER.....	12
INSTALLING THE TRANSMITTER.....	12-13
RECEIVER OUTPUT CONFIGURATION.....	13-15
INSTALLING THE RECEIVER.....	15
CONNECTING THE SYSTEM.....	15-16
SYSTEM VERIFICATION AND TROUBLESHOOTING.....	17
RECEIVER OUTPUT CIRCUIT DIAGRAM.....	17
<b>OPERATION:</b>	<b>18-19</b>
GENERAL OPERATION.....	18
CALIBRATION.....	18
FLOW METER SERVICING .....	18
SERVICE.....	18-19
<b>MAINTENANCE:</b>	<b>20-24</b>
PREVENTIVE MAINTENANCE.....	20
CLEANING THE METER AND TRANSMITTER.....	20
AUTOMATIC CLEANING OF THE FLOW METER.....	20-21
TROUBLESHOOTING GUIDE.....	22-24

(Continued next page)

	<b>PAGE</b>
<b>PARTS IDENTIFICATION:</b>	<b>26-29</b>
77786-XX RF 1 FIBER OPTIC FLOW METER KIT/PARTS LIST.....	26-27
A11516-XX RF 1 FIBER OPTIC FLOW METER KIT (USED WITH MCV- 2 COLOR CHANGER) / PARTS LIST.....	28-29
<b>WARRANTY POLICIES:</b>	<b>30</b>
LIMITED WARRANTY.....	30
<b>APPENDIX:</b>	<b>31-34</b>
PAINT AND SOLVENT GUIDE.....	31
VISCOSITY CONVERSION.....	32-33
VOLUMETRIC CONTENT OF HOSE OR TUBE.....	34

# SAFETY

## SAFETY PRECAUTIONS

Before operating, maintaining or servicing any ITW Ransburg electrostatic coating system, read and understand all of the technical and safety literature for your ITW Ransburg products. This manual contains information that is important for you to know and understand. This information relates to **USER SAFETY** and **PREVENTING EQUIPMENT PROBLEMS**. To help you recognize this information, we use the following symbols. Please pay particular attention to these sections.

**A WARNING!** states information to alert you to a situation that might cause serious injury if instructions are not followed.

**A CAUTION!** states information that tells how to prevent damage to equipment or how to avoid a situation that might cause minor injury.

**A NOTE** is information relevant to the procedure in progress.

While this manual lists standard specifications and service procedures, some minor deviations may be found between this literature and your equipment. Differences in local codes and plant requirements, material delivery requirements, etc., make such variations inevitable. Compare this manual with your system installation drawings and appropriate ITW Ransburg equipment manuals to reconcile such differences.

Careful study and continued use of this manual will provide a better understanding of the equipment and process, resulting in more efficient operation, longer trouble-free service and faster, easier troubleshooting. If you do not have the manuals and safety literature for your Ransburg system, contact your local ITW Ransburg representative or ITW Ransburg.



### WARNING



- ▶ The user **MUST** read and be familiar with the Safety Section in this manual and the ITW Ransburg safety literature therein identified.
- ▶ This manual **MUST** be read and thoroughly understood by **ALL** personnel who operate, clean or maintain this equipment! Special care should be taken to ensure that the **WARNINGS** and safety requirements for operating and servicing the equipment are followed. The user should be aware of and adhere to **ALL** local building and fire codes and ordinances as well as **NFPA-33 SAFETY STANDARD**, prior to installing, operating, and/or servicing this equipment.





### WARNING

- ▶ The hazards shown on the following page may occur during the normal use of this equipment. Please read the hazard chart beginning on page 2.

<b>AREA</b> Tells where hazards may occur.	<b>HAZARD</b> Tells what the hazard is.	<b>SAFEGUARDS</b> Tells how to avoid the hazard.
<p><b>Spray Area</b></p> 	<p>Fire Hazard</p> <p>Improper or inadequate operation and maintenance procedures will cause a fire hazard.</p> <p>Protection against inadvertent arcing that is capable of causing fire or explosion is lost if any safety interlocks are disabled during operation. Frequent power supply shutdown indicates a problem in the system requiring correction.</p>	<p>Fire extinguishing equipment must be present in the spray area and tested periodically.</p> <p>Spray areas must be kept clean to prevent the accumulation of combustible residues.</p> <p>Smoking must never be allowed in the spray area.</p> <p>The high voltage supplied to the atomizer must be turned off prior to cleaning, flushing or maintenance.</p> <p>When using solvents for cleaning:</p> <p>Those used for equipment flushing should have flash points equal to or higher than those of the coating material.</p> <p>Those used for general cleaning must have flash points above 100°F (37.8°C).</p> <p>Spray booth ventilation must be kept at the rates required by NFPA-33, OSHA, and local codes. In addition, ventilation must be maintained during cleaning operations using flammable or combustible solvents.</p> <p>Electrostatic arcing must be prevented.</p> <p>Test only in areas free of combustible material.</p> <p>Testing may require high voltage to be on, but only as instructed.</p> <p>Non-factory replacement parts or unauthorized equipment modifications may cause fire or injury.</p> <p>If used, the key switch bypass is intended for use only during set-up operations. Production should never be done with safety interlocks disabled.</p> <p>Never use equipment intended for use in waterborne installations to spray solvent based materials.</p> <p>The paint process and equipment should be set up and operational in accordance with NFPA- 33, NEC, and OSHA requirements.</p>

<b>AREA</b> Tells where hazards may occur.	<b>HAZARD</b> Tells what the hazard is.	<b>SAFEGUARDS</b> Tells how to avoid the hazard.
<p><b>General Use and Maintenance</b></p> 	<p>Improper operation or maintenance may create a hazard.</p> <p>Personnel must be properly trained in the use of this equipment.</p>	<p>Personnel must be given training in accordance with the requirements of NFPA-33.</p> <p>Instructions and safety precautions must be read and understood prior to using this equipment.</p> <p>Comply with appropriate local, state, and national codes governing ventilation, fire protection, operation maintenance, and housekeeping. Reference OSHA, NFPA-33, and your insurance company requirements.</p>
<p><b>Electrical Equipment</b></p> 	<p>High voltage equipment is utilized. Arcing in areas of flammable or combustible materials may occur. Personnel are exposed to high voltage during operation and maintenance.</p> <p>Protection against inadvertent arcing that may cause a fire or explosion is lost if safety circuits are disabled during operation.</p> <p>Frequent power supply shutdown indicates a problem in the system which requires correction.</p> <p>An electrical arc can ignite coating materials and cause a fire or explosion.</p>	<p>The power supply, optional remote control cabinet, and all other electrical equipment must be located outside Class I or II, Division 1 and 2 hazardous areas. Refer to NFPA-33.</p> <p>Turn the power supply OFF before working on the equipment.</p> <p>Test only in areas free of flammable or combustible material.</p> <p>Testing may require high voltage to be on, but only as instructed.</p> <p>Production should never be done with the safety circuits disabled.</p> <p>Before turning the high voltage on, make sure no objects are within the sparking distance.</p>
<p><b>Explosion Hazard / Incompatible Materials</b></p> 	<p>Halogenated hydrocarbon solvents for example: methylene chloride and 1,1,1-Trichloroethane are not chemically compatible with the aluminum that might be used in many system components. The chemical reaction caused by these solvents reacting with aluminum can become violent and lead to an equipment explosion.</p>	<p>Aluminum is widely used in other spray application equipment - such as material pumps, regulators, triggering valves, etc. Halogenated hydrocarbon solvents must never be used with aluminum equipment during spraying, flushing, or cleaning. Read the label or data sheet for the material you intend to spray. If in doubt as to whether or not a coating or cleaning material is compatible, contact your material supplier. Any other type of solvent may be used with aluminum equipment.</p>

<b>AREA</b> Tells where hazards may occur.	<b>HAZARD</b> Tells what the hazard is.	<b>SAFEGUARDS</b> Tells how to avoid the hazard.
<b>Toxic Substances</b> 	Certain material may be harmful if inhaled, or if there is contact with the skin.	Follow the requirements of the Material Safety Data Sheet supplied by coating material manufacturer.  Adequate exhaust must be provided to keep the air free of accumulations of toxic materials.  Use a mask or respirator whenever there is a chance of inhaling sprayed materials. The mask must be compatible with the material being sprayed and its concentration. Equipment must be as prescribed by an industrial hygienist or safety expert, and be NIOSH approved.
<b>Spray Area / High Voltage Equipment</b> 	There is a high voltage device that can induce an electrical charge on ungrounded objects which is capable of igniting coating materials.  Inadequate grounding will cause a spark hazard. A spark can ignite many coating materials and cause a fire or explosion.	Parts being sprayed must be supported on conveyors or hangers and be grounded. The resistance between the part and ground must not exceed 1 megohm.  All electrically conductive objects in the spray area, with the exception of those objects required by the process to be at high voltage, must be grounded.  Any person working in the spray area must be grounded.  Unless specifically approved for use in hazardous locations, the power supply and other electrical control equipment must not be used in Class 1, Division 1 or 2 locations.
<b>Personnel Safety/ Fluid Injection Hazard (High Pressure Equipment)</b> 	Fluid Injection Injury	Never let any part of the body come in direct contact with the fluid stream exiting from the nozzle. If fluid leaks occur in the gun or in the fluid delivery components, depressurize fluid system before servicing.  Never aim the applicator at any part of the body under any circumstances.  If you are injured by high pressure fluid injection, immediate medical treatment must be sought.
<b>Intended Use (Waterborne Only)</b>	Using coating materials and/or cleaning and flushing solvents which have flash points below 100°F (37.8°C) may cause a fire hazard.	This system is intended for use with waterborne coating formulations only.  Waterborne, waterbase and water reducible coatings are considered the same. Although they may not be highly flammable, their residues are considered combustible.



**NOTES**

# INTRODUCTION

## THEORY OF OPERATION

Fluid flowing through the flow meter causes the spur gears within the meter to rotate at a speed, which is proportional to the rate of flow through the meter. The total number of gear rotations is proportional to the total amount of fluid that flowed through the meter during these gear rotations. When fluid flows through the meter in a given direction the gears rotate in one direction. When the direction of flow is reversed the gears rotate in the opposite direction. Measurement of the gear rotation and direction provides the information that the control system requires.

The fiber transmitter is located on top of the flow meter. Two variable reluctance type pickups extend from the transmitter enclosure and into the flow meter. These pickups are positioned over the teeth of the rotating gears. As the ferrous (magnetic) gear teeth rotate past each sensor it causes the pickup to see a changing magnetic field. This changing magnetic field is converted into an electrical signal by the coil inside each pickup.

Two pickups are used such that that rotation direction information can be determined. The pickups are located such that the signals that they produce are in quadrature or 90 degrees out of phase to each other. In one direction pickup "A" is high while pickup "B" goes high. In the other direction pickup "B" is high while pickup "A" goes high. The electronics detects these two conditions to determine the direction of rotation and hence fluid flow.

The signals from the pickups are fed into the electronics module. The electronics module first conditions the signals from the pickups to turn them into logic level digital signals. The flow rate and direction information is then extracted. This information is then encoded into a form that can be used to modulate an LED. The encoded information is then fed to a driver circuit that drives the LED.

A self-contained non-replaceable battery powers the transmitter. This battery is designed to provide power for several years of use under normal operating conditions. The signal encoding method is designed to use the minimum amount of battery power while fluid is flowing in the forward direction. Power consumption goes up significantly if the meter is run in the reverse direction.

The encoded optical pulse stream is conveyed through the fiber cable to the receiver. The receiver first converts the encoded light pulses back into electrical signals. These pulses are then fed into a microcontroller that decodes them. The decoded outputs consist of channel "A" and channel "B" quadrature signals. These signals are then fed to the output section where they are converted into one of four different formats for driving the attached control equipment

## TRANSMITTER

The transmitter is contained in a plastic enclosure and was designed to be mounted to the top of the flow meter. The meter and transmitter are designed to be intrinsically safe. Thus they can be mounted in hazardous (classified) locations containing potentially explosive atmospheres.

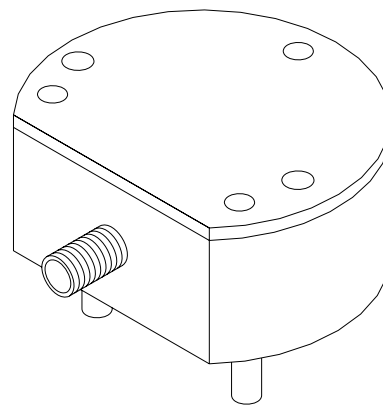

Figure 1: Transmitter

Two reluctance type pickups protrude from the bottom of the transmitter enclosure. When mounted on a flow meter these pickups sense the rotation of the gears beneath them in the flow meter. Two pickups are used so that the direction of the gear rotation and fluid flow rate can be determined. A connector for the fiber optic cable protrudes from the side of the enclosure.

## RECEIVER

The receiver module is enclosed in a small rectangular die cast enclosure. A fiber optic connector protrudes from one end. An electrical connector protrudes from the other. The receiver is designed to be mounted outside of the hazardous area. It can be mounted either on a wall or inside of an industrial control cabinet. The mounting ears on each end of the enclosure can be removed to facilitate alternate mounting means. An optional DIN rail mount bracket is available.

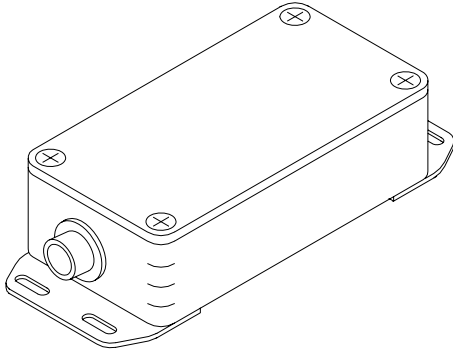

Figure 2: Receiver

## FIBER OPTIC CABLING

This fiber optic transceiver system uses a custom designed cabling system. The cabling system consists of a connector, the plastic optical fiber and protective polyethylene tubing. The polyethylene tubing protects the internal plastic fiber from excessively tight radius bends that would damage it. The protective polyethylene outer jacket also keeps the enclosed fiber from absorbing chemical vapors that would degrade the fiber's ability to transmit light over time.

The cabling is purchased and installed as a completed assembly. **Field splicing or modification of length is not possible.** Refer to "Table A - Fiber Optic Cable" in the "Parts Identification" section for available cable lengths.

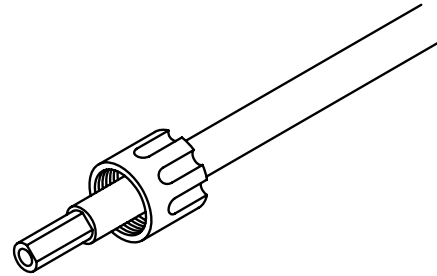

Figure 3: Fiber Optic Cable Assembly

## HANDLING & STORAGE PRECAUTIONS

<b>⚠ CAUTION</b>
<p>► The transmitter contains a non-replaceable battery power source which is designed to power the unit for several years of normal operation. The transmitter functions by detecting very weak magnetic fields. Exposure to stray magnetic fields during shipping, handling, and storage can prematurely deplete the battery. Keep the transmitter at least 12" away from devices which generate stray magnetic fields. Examples of these devices are energized transformers, florescent light ballasts, TVs, computer monitors, and line-energized wiring.</p>

<b>⚠ CAUTION</b>
<p>► The two reluctance pickups protruding from the bottom of the transmitter enclosure are magnetic. Keep them away from magnetic media (floppy diskettes) to avoid loss of data.</p>

**CAUTION**

► The fiber optic cable assemblies contain a plastic optical fiber that can be permanently damaged if bent in too small of a radius. Observe the minimum bend radius as noted in the specifications section of this manual.

Keep the transmitter pickups away from rust, iron filings, and other magnetic debris which will stick to the pickups. This debris will not cause any damage to the transmitter but will need to be completely removed before the transmitter is mounted on a flow meter.

Protect the fiberoptic connectors on both the transmitter and receiver from the ingress of dirt, dust and debris until the fiber cabling is attached.

**FLOW RATE ACCURACY**

Flow rate accuracies of 0.5% are not uncommon with many fluids if the flowmeters are calibrated at or near the expected flow rates. Even with wide flow rate swings (such as when used with robots under analog control) accuracies of +/- 2% are achievable.

**REVERSE FLOW DETECTION**

Sensors are of the quadrature type, which allows reverse flow detection, if necessary. Under conditions where reverse flow detection is not necessary, only one sensor output is used, leaving the second sensor output as a spare output that can be used if the first sensor should ever fail or used in parallel to drive remote flow displays, etc.

**FLUID PASSAGES**

The high pressure RF 1's side inlet port uses a 3/8" AN female fitting. This style fitting eliminates flow "dead space" or exposed threads, and also eliminates the need for specially designed fittings or Teflon inserts. By creating a streamlined fluid passage, color change time of the meter is improved.

The low pressure RF 1's bottom inlet unit mounts directly to the MCV block and is sealed by o-rings.

**MOUNTING LOCATION FOR THE TRANSMITTER****CAUTION**

► The transmitter functions by detecting changes in very weak magnetic fields caused by the rotation of the gears within the flow meter. Unfortunately, it will also respond to stray magnetic fields if they are present from other sources. Stray fields can be caused by nearby transformers, relays, solenoids, or AC line energized wiring. For proper operation, the transmitter must be located away from these stray fields. Installing the transmitter in a location that exposes it to stray magnetic fields will result in improper operation.

## SPECIFICATIONS

### Transmitter

#### MECHANICAL

<b>Enclosure Material:</b>	Fiber Filled Nylon 6/6
<b>Fiber Connector Material:</b>	Delrin
<b>Fiber Cable Orientation:</b>	Parallel with fluid connections.
<b>Transmitter Mounting:</b>	Polarized (one way only)

#### ENVIRONMENTAL

<b>Operating Temp.:</b>	(-40° to + 158° F)
<b>Range:</b>	(-40° to + 70° C)
<b>Accuracy:</b>	+/- 0.5% (system dependent)

<b>Working Pressure</b>	
<b>77786-XX:</b>	5000 psi (345 Bar) MWP @ 100°F
<b>A10830 &amp; A10883:</b>	500 psi (34 Bar) MWP @ 100°F

#### ELECTRICAL

<b>Battery Life:</b>	1.5 years minimum
----------------------	-------------------

#### REGULATORY

<b>Classification:</b>	Intrinsic Safety - Class 1, Division 1, Groups C, D
<b>Approvals:</b>	FM (Factory Mutual) Class 3600 & 3610

#### ELECTROMAGNETIC COMPATIBILITY

<b>U.S.:</b>	FCC Part 15 Class A Industrial
<b>Europe:</b>	CE Heavy Industrial

#### MATERIAL OF CONSTRUCTION

<b>Body:</b>	303 Stainless Steel
<b>Gears:</b>	Stainless Steel (Hardened)
<b>Bushings:</b>	Carbide
<b>Shafts:</b>	Carbide
<b>Seal:</b>	Teflon
<b>Filtration:</b>	100 Mesh (minimum)
<b>Connections:</b>	Threaded 3/8" AN (F)
<b>Weight:</b>	4.5 lbs. (2.0 kg)

### Receiver

#### MECHANICAL

<b>Enclosure Material:</b>	Diecast Aluminum
<b>Enclosure Size:</b>	Approx. 2.375" X 4.5" X 1.25" (Excluding connectors)
<b>Enclosure Ingress:</b>	IP50
<b>Protection (IP) Class</b>	
<b>Enclosure Mounting Means:</b>	Flanges with through holes or direct to enclosure with tapped holes.

#### ELECTRICAL

<b>Power Supply Input Voltage:</b>	8-30 Volts DC Reverse polarity protected
<b>Power Supply Input Current:</b>	100 mA maximum
<b>Output Pulse Width:</b>	1.0mS pseudo- quadrature
<b>Output Configurations:</b>	Isolated Open collector 5 Volt Logic Vin Logic (std. from factory)
<b>Output Current (source or sink):</b>	5.0 mA maximum

#### ELECTROMAGNETIC COMPATIBILITY

<b>U.S.:</b>	FCC Part 15 Class A Industrial
<b>Europe:</b>	CE Heavy Industrial

(Continued on next page)

## System

### FIBER OPTIC LINK

**Light Wave Length:** 660 nM (visible red)  
**Operational Length:** 0 to 100 ft.  
**Fiber Connector:** Proprietary  
**Fiber Cable:** 980/1000 mM plastic fiber encased in 1/4" OD polyethylene pneumatic tubing

#### Fiber Cable Bend

**Radius:** 6 in. Minimum  
**Available Cable Lengths:** 10, 15, 25, 50, 65, 75, and 100 ft.

(For other lengths please consult manufacturing facility.)

### PULSE FREQUENCY (OUTPUT)

(Flow rate on meter)

**Minimum:** 1.2 Hz  
(72 pulses/min or 9 cc/min)

**Maximum:** 475 Hz.  
(28,500 pulses/min or 3,517 cc/min)

**Signal Output:** 2 Channel Quadrature  
8,100 pulses/liter or 30,660 pulses/gal.

## NOTES

# INSTALLATION

Ensure proper fluid filtration is provided on the inlet side of the flow meter. The unit may be mounted using the mounting bolt pattern shown in Figure 4. Two (2) 1/4 - 20 bolts should be used. Always mount the flow meter with the gear faces perpendicular to the horizon of the earth (i.e. - Vertical). This minimizes the effect of gravity on the gears. The direction of flow must be plumbed as marked on the side label of the meter. The fluid inlet is opposite the sensor connection.

## NOTE

- For waterborne applications the meter body should be isolated from ground.

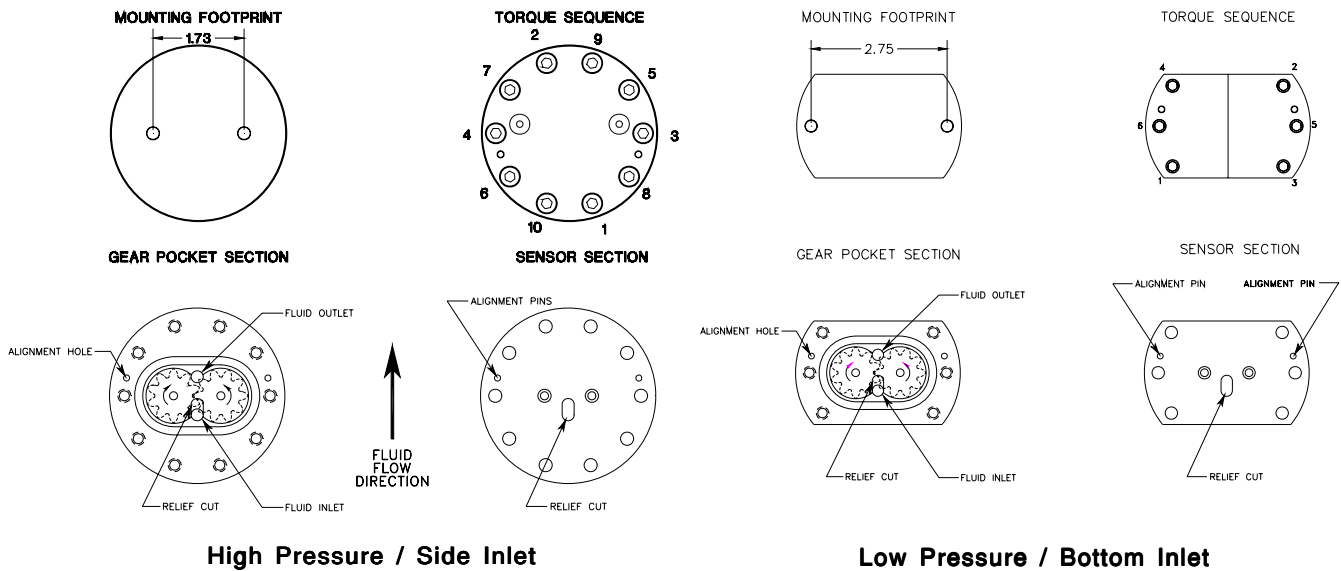

Figure 4: Views of Flow Meter Bodies

## INSTALLATION LOCATIONS FOR TRANSMITTER AND RECEIVER

The fiber optic transmitter / flow meter is designed to be intrinsically safe and may be mounted in a hazardous (classified) location which may contain a potentially explosive atmosphere. The transmitter is intrinsically safe as long as it is installed in accordance with the hazardous area classification defined in the "Specification" section in the "Introduction" section of this manual.

### WARNING

- ▶ Installing the transmitter in a hazardous area more severe than that for which it is rated poses a risk of fire, explosion, and bodily injury up to and including death.

The transmitter functions by detecting changes in very weak magnetic fields caused by the rotation of the gears within the flow meter. Unfortunately it will also respond to stray magnetic fields if they are present. Stray fields can be caused by nearby transformers, relays, solenoids, or AC line energized wiring. For proper operation the transmitter must be located away from these stray fields.

### CAUTION

- ▶ Installing the transmitter in a location that exposes it to stray magnetic fields will result in improper operation. The meter body must also be grounded to true earth ground for proper operation.

The fiber optic receiver is not designed to be intrinsically safe and must not be mounted in a hazardous (classified) location. If you are unsure about what constitutes a hazardous area please refer to your local electrical codes.

### WARNING

- ▶ Installing the receiver in a hazardous area poses a risk of fire, explosion, and bodily injury up to and including death.

## INSTALLING THE TRANSMITTER (Onto the Flow Meter)

Pick a suitable location as outlined above. Keep in mind the physical fluid connections and the fiber optic cable connection. The meter / transmitter combination is designed for fluid flow in one primary direction. The fluid inlet to the high pressure meter is located below the fiber cable connector and on the bottom of the low pressure unit.

### CAUTION

- ▶ Running the meter / transmitter in the reverse direction will cause no operational problems but will result in a significant decrease in the life of the transmitter battery and hence the transmitter.

### CAUTION

- ▶ The low frequency performance of the transmitter is dependent on the spacing between the pickups and the gears inside the flow meter. Dirt or debris between the meter and transmitter that increases this distance may result in poor operation of the meter at low flow levels.



Mount the transmitter to the meter as follows:

1. Inspect the top of the meter and the holes for the pickups. The top meter surface and pickup receptacles in the top of the meter must be free of dirt and debris that would interfere with mounting of the transmitter or increase the distance between the pickups and the gears. Clean both of these areas as required.
2. Inspect the pickups on the transmitter. The pickup tips are magnetic and will tend to attract magnetic debris. Any debris that has attached itself to the pickups must be removed before the transmitter is mounted on the meter. A small stiff brush is useful for removing this debris.
3. Remove the three (3) screws that secure the transmitter cover and remove the cover.
4. Place the transmitter on top of the meter with the fiber connector oriented towards the fluid inlet on the meter.
5. Install a #8-32 x 1" socket head cap screw in each of the transmitter mounting holes. Tighten these evenly until they are snug.
6. Install the transmitter cover in the reverse order that it was removed.

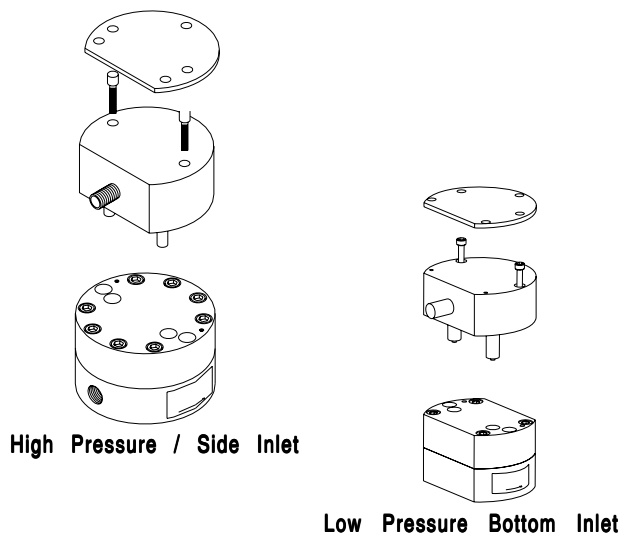

**Figure 5: Mounting the Transmitter to the Meter**

## RECEIVER OUTPUT CONFIGURATION

The receiver can provide its output in any one of four different formats. The format chosen depends on the controller to which the receiver is attached. The receiver outputs signals on two channels, channel A and channel B. A set of six (6) jumpers (three for each channel), are used to set the receiver output format. A description of each output format is shown as follows:

### Positive 5 Volt Logic Output

In this output configuration the receiver outputs a 5-Volt logic signal regardless of the input supply voltage to the receiver. The output signals are shown in Figure 6.

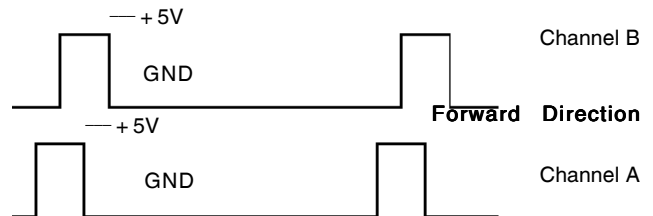
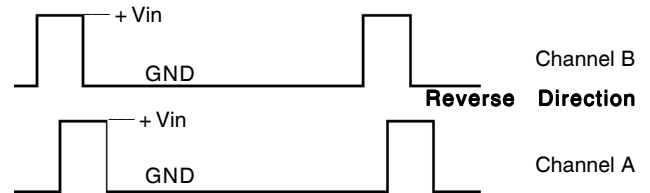

**Figure 6: Mounting the Transmitter to the Meter**

*Application examples of Positive 5 Volt Logic would be for use with TTL Logic Circuitry.*

### Positive Vin Logic Output

In this output configuration the receiver outputs a logic signal that tracks the input supply voltage to the receiver. The output signals are shown in Figure 7.



**Figure 7: Vin Logic Output**

Applications for Vin Logic would be standard Industrial Control Circuitry. This is the configuration that the receiver is shipped with from the factory.

### Open Collector Output

In this output configuration the receiver provides access to the collector of the output transistor. The controller must provide a current limited voltage source (+Voc) to the receiver outputs. The output signals are as shown in Figure 8.

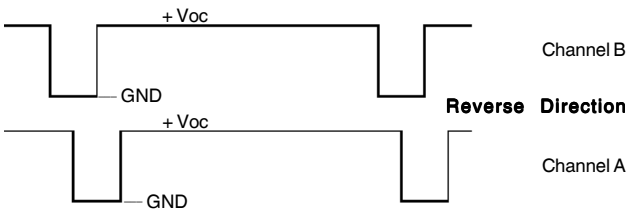

Figure 8: Open Collector Output

Applications for open collector outputs would be for driving high speed counter cords on PLC's.

### Isolated Output

In this output configuration the receiver outputs are galvanically isolated from the receiver power supply and the reset of the receiver circuitry. In this configuration the outputs behave like switches except that current will only flow one way when the switch is closed. This source of current must be current limited to 50mA and supplied to the receiver from the controller for use to simulate a positive DC only relay. (Maximum DC voltage must not exceed 30 volts.)

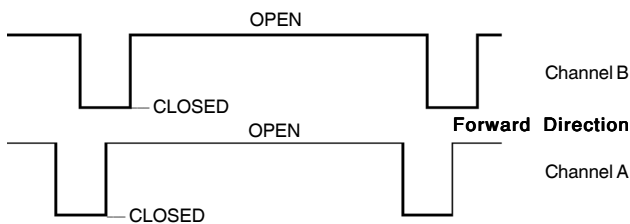

Figure 9: Isolated Output

### Changing Output Configuration

Once you have determined the correct output configuration, programming the receiver is simply a matter of setting jumpers on the receiver PCB. Configure the receiver as follows:

1. Remove the four (4) screws that secure the lid of the receiver enclosure and remove the lid.
2. Locate the six (6) jumpers that control the output configuration. They are shown in the following Figure 10.

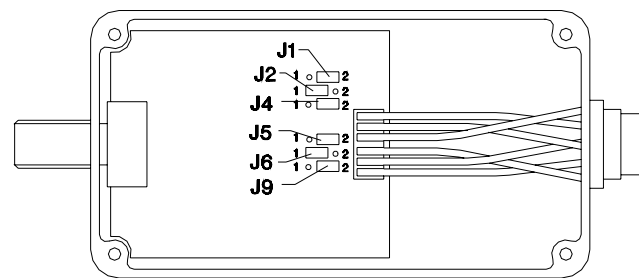

Figure 10: Receiver Output Configuration Jumpers

3. Set the jumpers as shown in Figures 11a and 11b for the desired output configuration.

Output Type	J1,5	J2,6	J4,9	Polarity
Open Collector	Open	1	2	L
5V Logic	1	2	1	H
Vin Logic *	2	2	1	H
Isolated	Open	1	Open	N/A

\*Factory Default Configuration

Figure 11a: Jumper Configuration

ITW Ransburg Equipment	J1,5	J2,6	J4,9	Polarity
AdaptaFlow	2	1	2	H
Totalizer *	2	2	1	H
2K 220 *	2	2	1	H
2K 880 *	2	2	1	H
E-Z Flow *	2	2	1	H
DynaFlow	2	1	2	H

\*Factory Default Configuration

Figure 11b: Jumper Configuration

**NOTE**

► Jumper settings other than the ones listed in Figures 11a and 11b are not recommended and may cause erratic readings.

**NOTE**

► When setting a jumper to “open” place the jumper over a single pin of the corresponding jumper block. This saves the jumper for possible future use.

4. Do not replace the receiver lid just yet. You will need access to the inside of the receiver during the system checkout procedure.

## INSTALLING THE RECEIVER

The receiver is designed so that it can be mounted on a wall outside of the hazardous area or inside of an industrial control panel. Pick a location where it will be accessible for service and there will be sufficient space for both the fiber and electrical cables.

Mount the receiver as follows:

1. Pick a suitable location outside of the hazardous area that contains a flat surface. Be sure that there is enough room for both the electrical and fiber cables.
2. Using the receiver as a template or the dimensions from Figure 12, mark the mounting hole locations.

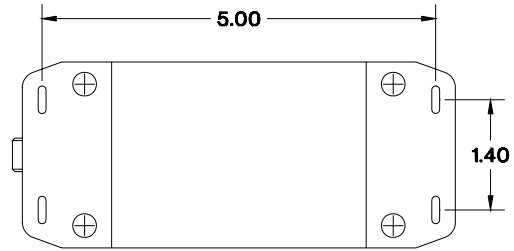

**Figure 12: Receiver Mounting Hole Locations**

3. Remove the two mounting ears if required. This will be for instances when the receiver will be mounted to a panel from behind.
4. Fasten the receiver to the mounting surface using the appropriate #6-32 hardware.

## CONNECTING THE SYSTEM

### Wiring the Receiver

The receiver is connected to the controller through an industry standard 6 position DIN connector. The specification section lists two vendors of mating connectors and corresponding part numbers.

The cable used for connecting the receiver to the controller can be most any type of instrumentation cable. The typical characteristics of the cable are 22 AWG stranded conductors with an overall foil shield.

The connector wiring for each output configuration is shown below.

<b>Output Type</b>	<b>Channel A Pins</b>	<b>Channel B Pins</b>
Open Collector	1 & 2	3 & 4
5V Logic	1 & 5	4 & 5
Vin Logic*	1 & 5	4 & 5
Isolated	1 (+) & 2 (-)	3 (+) & 4 (-)

**Figure 13: Cabling Configuration**

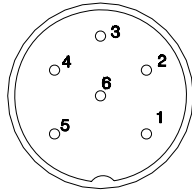

**Figure 14: Connector Pin Location**

Pin #	Description	Wire Color	Location
1	A hi	Red	4 Strand Wire
2	A lo	Black	4 Strand Wire
3	B hi	White	4 Strand Wire
4	B lo	Green	4 Strand Wire
5	(digital ground) (OV)	Blue	Seperate Wire
6	8-30 VDC	Black	Seperate Wire

**Figure 15: Wire Descriptions for 77452-00**

(Reference Figure 16 for the Receiver Output Circuit Diagram.)

### Installing the Fiber Optic Cable

The transmitter is connected to the receiver by way of a fiber optic cable assembly. This cable comes in standard lengths with the fiber connectors already attached.

Install the fiber optic cable as follows:

1. Install a retaining nut on one end of the fiber cable assembly. Push it on such that about 2" of the connector end of the cable protrudes through the connector.
2. Push the connector end of the cable into the transmitter fiber receptacle until it bottoms.
3. Slide the retaining nut up to the transmitter receptacle and tighten until it is snug.
4. Route the fiber cable to the receiver. Secure it as necessary to prevent unwanted movement after installation. Be careful to observe the minimum bend radius specification.
5. It is likely that the standard cable lengths will leave some cable left over. Plan a location where this extra cable can be coiled and stored. When coiling the cable be careful to observe the minimum bend radius specification.
6. At the receiver install a retaining nut on the cable and connect the cable to the receiver in the same manner as the transmitter.

**⚠ CAUTION**

▶ Treat the connector ends of the fiber cable assembly with care. Be careful not to scratch or otherwise damage the light carrying face of the connector. Protect the connectors if necessary during the installation.

**⚠ CAUTION**

▶ Do not treat the fiber optic cable like regular copper wire! The fiber cable can be damaged if it is bent too sharply. Please observe the minimum bend radius specification during installation.

# SYSTEM VERIFICATION AND TROUBLESHOOTING

## Verifying a New Installation

The fiber optic transmitter / receiver system contains two (2) diagnostic LEDs that are located in the receiver. These indicators make it easy to verify proper operation.

To verify proper operation perform the following steps:

1. Cause fluid to flow in the meter in the forward direction at a flow rate greater than 10cc/min.
2. Observe the diagnostic LEDs located on the receiver PCB. The green “forward” LED should be flashing. One flash is generated each time a gear tooth passes the pickup tip.

**NOTE**

► Flow rates lower than approximately 10cc/min. will not be detected in either forward or reverse direction.

3. The flashing green led verifies the transmitter, fiber cabling, and about 75% of the receiver circuitry.
4. The system should be functioning normally at this point. If it is, replace the cover on the receiver. If not, proceed to the following troubleshooting section.

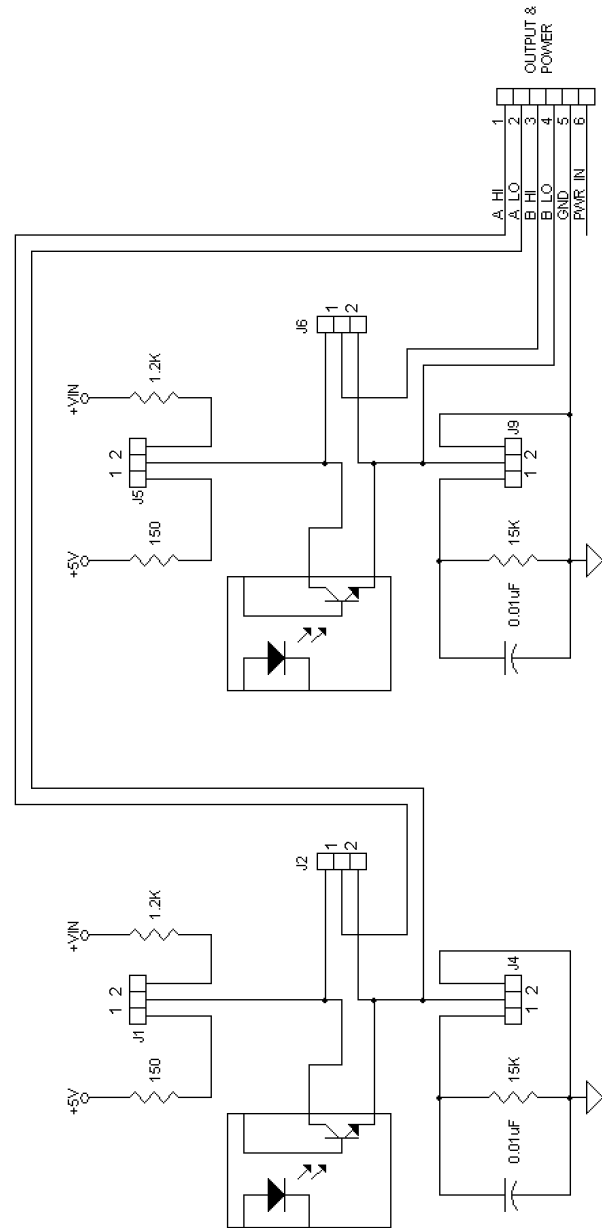

**Figure 16: Receiver Output Circuit Diagram**

# OPERATION

## GENERAL OPERATION

To operate the unit, connect the unit in place per installation instructions. Allow paint to flow through the meter. Read results through appropriate display.

## CALIBRATION

Refer to appropriate associated equipment for calibration procedure.

## FLOW METER SERVICING

Flow meter problems can be caused by improperly filtered fluid. Particulates in the fluid can cause gear binding, resulting in improper signals for the actual flow rate. Maintain the fluid filters according to the instructions from the filter manufacturer. If repeated disassembly and cleaning for removal of solids and particulates occurs, inspect the entire fluid supply system and evaluate the system cleaning cycle.

Fluid back-up, that is reverse flow of 2k components, can cause reacted/catalyzed material to enter the flow meter. Reverse flow must be detected by the 2k controls and the system must shut down. The flow meter should be cleaned immediately, before the fluid sets-up.

## SERVICE

1. Disconnect fiber optic cable [13] from transmitter [1]. Remove meter to a suitable area to perform maintenance.

2. Remove three (3) Phillips head screws from transmitter [1]. Remove cover plate. Remove two (2) #8 - 32 x 1" socket head cap screws. Remove transmitter [1] from the flow meter body.

3. Using a 3/16" Allen wrench, remove all the bolts. Pull the sensor section STRAIGHT apart from the gear pocket section. Pull the gears and pins from the gear pocket section. Clean and replace worn parts as necessary.



### CAUTION

► Do not pry the halves of the flow meter body apart using screwdrivers or other pry tools. (This could damage the flow meter shaft and bushings, destroying the flow meter.) If the body does not separate easily, replace two (2) of the bolts near the sensor holes and only screw them in two or three threads in the bottom half of the body. Then, hold the top half of the body in your hand and tap on the bolt heads using a soft headed hammer to jar the body halves apart.

4. Install new Teflon o-ring [6]. Install all parts the order they were removed. Install flated portion of shafts [4] toward gears (see Figure 3). Push the two (2) covers together, aligning the pins and holes by hand.

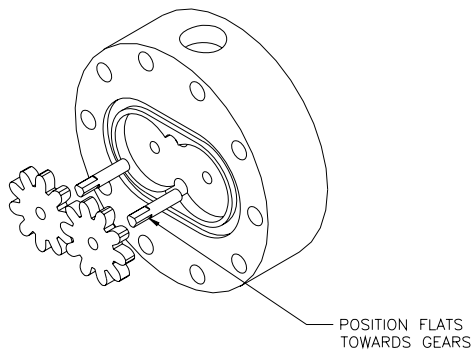

**Figure 17: View of Flated Portion of Shafts**

### **NOTE**

- ▶ The flow meter uses alignment pins to ensure that the two body halves can only be assembled in one way.

5. Snug all screws down. Tighten the screws in the sequence pattern shown in Figure 4 to 13 lbs. per ft. torque. This is a cross pattern to insure proper gasket setting.
6. Install transmitter on to body.
7. Reconnect meter into system.

## **NOTES**

# MAINTENANCE

## PREVENTIVE MAINTENANCE

The fiber transmitter and receiver are designed to be a rugged and reliable system. Periodic preventative maintenance is not required.

## CLEANING THE METER AND TRANSMITTER

In some applications the RF 1 meter is used in an application where the exterior of the meter and transmitter must be periodically cleaned. An example of such an application would be serving as a paint meter in a paint booth system.

### CAUTION

► Do not treat the fiber optic cable like regular copper wire! The fiber cable can be damaged if it is bent too sharply. Please observe the minimum bend radius specification during installation.

## Cleaning with Water Based Solvents

The meter itself is made out of stainless steel and is impervious to water based solvents so that no precautions are necessary with the meter. The transmitter and its components are enclosed in a nylon enclosure which is highly resistant to water based solvents. As a precaution avoid the possibility of forcing the cleaning solution into the fiber cable connector or the small gap between the transmitter and the meter.

## Cleaning with Chemical Based Solvents

The meter itself is made out of stainless steel and is impervious to chemical based solvents so that no precautions are necessary with the meter. The transmitter and its components are enclosed in a nylon enclosure that is resistant to chemical solvents such as MEK. When using solvents such as MEK use as little as possible and keep the contact time with the transmitter as short as possible. Avoid the possibility of forcing the cleaning solvent into the fiber cable connector or the small gap between the transmitter and the meter.

## AUTOMATIC CLEANING OF THE FLOW METER

### Fluid Line Air Purges

Air purges are often used in automatic coating operations for rapid color changes and to minimize the amount of solvent required to flush-out the old color. Special considerations must be made when using air purges through the flow meter.

1. Air purges do not provide the lubrication the flow meter gears require. Lubrication is normally provided by the metered fluid or solvent.
2. Air purges can cause some coating materials to “dry” on the flow meter shafts and gears thus affecting the performance characteristics of the flowmeter, especially when water-based materials are used.
3. Excessively long air purges will cause premature gear and shaft failure.



4. All clean cycles should begin with a solvent push to prevent drying of coating material on flowmeter parts.
5. Solvent and air “chop” cycles are recommended as the most efficient way of flushing flow meters.
7. Air purge cycles are not recommended in water-based applications

**NOTES**

## TROUBLESHOOTING GUIDE

General Problem	Possible Cause	Solution
<b>NEW INSTALLATION</b>		
<p><b>Neither receiver LED flashes with fluid flow in the meter. System appears dead</b></p>	<ol style="list-style-type: none"> <li>1. No DC power to the receiver</li> <li>2. Insufficient fluid flow through the meter</li> <li>3. No light pulses from transmitter</li> </ol>	<ol style="list-style-type: none"> <li>1. Check receiver wiring. Verify +8-30 VDC at pin 6 of J8 on the receiver PCB.</li> <li>2. Increase fluid flow through the meter. The flow must be greater than 10cc/min. to be detected.</li> <li>3. Remove the fiber cable from the transmitter and look into the fiber connector on the transmitter. Faint red light pulses should be seen. It may be necessary to use an inspection mirror and shield against ambient light to see this.</li> </ol>
<p><b>Light pulses verified at transmitter. Receiver still dead</b></p>	<ol style="list-style-type: none"> <li>1. Fiber cable not fully seated in the connector at transmitter or receiver</li> <li>2. Fiber connections dirty</li> <li>3. Defective or damaged fiber cable assembly</li> </ol>	<ol style="list-style-type: none"> <li>1. Reseat the cable in the fiber connector on both ends.</li> <li>2. Clean them using glass cleaner and a soft cloth or cotton swab.</li> <li>3. Replace fiber cable assembly</li> </ol>
<p><b>No light pulses at transmitter</b></p>	<ol style="list-style-type: none"> <li>1. Seized / defective meter</li> <li>2. Defective transmitter</li> </ol>	<ol style="list-style-type: none"> <li>1. Replace meter.</li> <li>2. Replace transmitter.</li> </ol>
<p><b>The red "reverse" LED flashes with forward flow through the meter</b></p>	<ol style="list-style-type: none"> <li>1. Meter installed backwards. Fluid inlet is on same side of meter as the fiber connector.</li> <li>2. Defective transmitter</li> </ol>	<ol style="list-style-type: none"> <li>1. Turn meter around.</li> <li>2. Replace transmitter</li> </ol>

(Continued on next page)

General Problem	Possible Cause	Solution
<b>NEW INSTALLATION (Cont.)</b>		
<b>Green “forward” LED in the receiver flashes but the controller sees reverse flow</b>	<ol style="list-style-type: none"> <li>1. Channels “A” and “B” reversed at the controller</li> <li>2. Incorrect receiver output configuration</li> <li>3. Channels “A” and “B” incorrectly wired</li> <li>4. Receiver output configuration incorrect</li> </ol>	<ol style="list-style-type: none"> <li>1. Rewire the receiver at the controller.</li> <li>2. Correct the receiver output configuration.</li> <li>3. Correct wiring.</li> <li>4. Correct the receiver output configuration.</li> </ol>
<b>No or erratic operation at low flow rates</b>	<ol style="list-style-type: none"> <li>1. Transmitter not seated properly on the meter caused by dirt and debris under the transmitter, on the pickups, or in the pickup receptacles</li> <li>2. Meter is binding</li> <li>3. Defective transmitter</li> </ol>	<ol style="list-style-type: none"> <li>1. Clean meter and transmitter mounting surfaces, pickups, and pickup receptacles to eliminate the problem.</li> <li>2. Replace meter.</li> <li>3. Replace transmitter.</li> </ol>
<b>Green and/or red LEDs flash with no fluid flowing through the meter</b>	<ol style="list-style-type: none"> <li>1. Stray magnetic fields are interfering with the transmitter. This may be confirmed by temporarily relocating the transmitter while leaving the fiber cable attached.</li> </ol>	<ol style="list-style-type: none"> <li>1. Relocate the transmitter away from the stray fields or relocate the wiring or equipment generating the stray field away from the transmitter.</li> </ol>
<b>EXISTING INSTALLATION</b>		
<b>Receiver LEDs not flashing even with sufficient fluid flow</b>	<ol style="list-style-type: none"> <li>1. Fiber cable has become contaminated from exposure to chemical vapors.</li> <li>2. Fiber connector interface at the transmitter has become contaminated by ingress of solvent, chemicals, and dirt.</li> </ol>	<ol style="list-style-type: none"> <li>1. Replace the fiber cable.</li> <li>2. Inspect the optical interface on both the cable and transmitter. A shiny reflection should be seen on the face of the LED in the transmitter. The connector on the end of the fiber cable should also look smooth and clean. Replace damaged components as required.</li> </ol>

(Continued on next page)

General Problem	Possible Cause	Solution
<b>EXISTING INSTALLATION (Cont.)</b>		
<b>Receiver LEDs not flashing even with sufficient fluid flow (Cont.)</b>	3. Battery is worn out in the transmitter. Confirm by substituting a known good unit.  4. Flow meter gears locked up.  5. Flow meter gears stall due to cleaning solvent / paint incompatibility.	3. Replace the transmitter.  4. Clean meter, insure proper filtration is use.  5. Consult material manufacturer for proper cleaning solvent.
<b>Receiver LEDs not flashing or on continuously with or without fluid flow.</b>	1. Receiver confused by power glitch.	1. Cycle power to the receiver and/or controller.
<b>Poor meter accuracy at low flow rates (meter has never been rebuilt).</b>	1. Gears inside the meter are worn allowing fluid slippage	1. Rebuild the meter and replace the gears and shafts.
<b>Poor meter accuracy at low flow rates (meter has previously been rebuilt).</b>	1. Gears and meter chamber are worn allowing fluid slippage	1. Replace the meter and the transmitter as a unit.

**NOTES**

# PARTS IDENTIFICATION

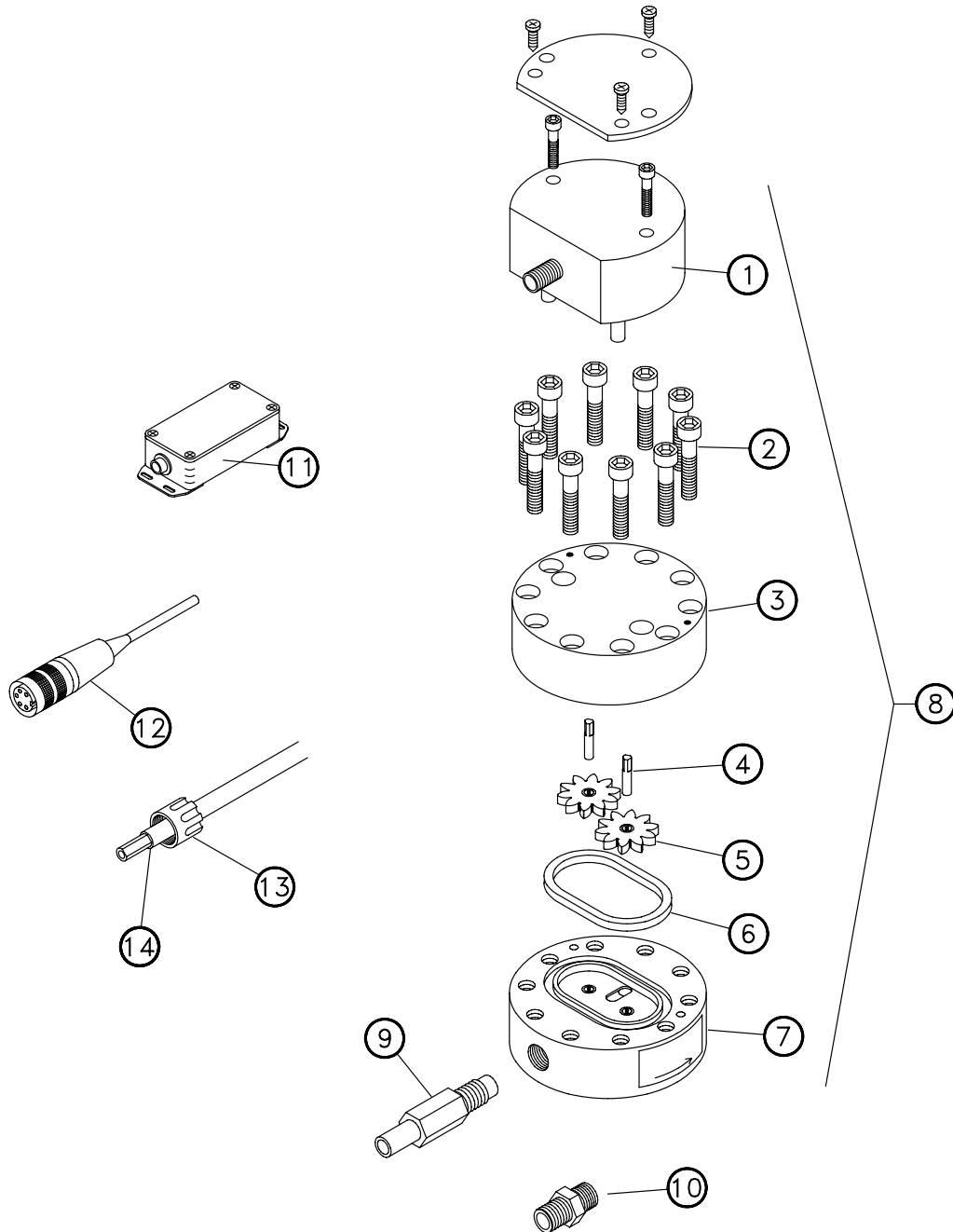

Figure 18: 77786-XX RF 1 Fiber Optic Flow Meter Kit

77786-XX RF 1 FIBER OPTIC FLOW METER KIT - PARTS LIST (Figure 18)			
Item #	Part #	Description	Qty
1	77355-00	Transmitter	1
2	Grade 8 or Better	Screw, 1/4" - 20 X 1-1/4 Lg., Socket Head Cap	10
3	N/A	Housing, Upper	1
4	76271-00	Shaft (2 Required)	2
5	76270-00	Gear (2 Required)	2
	76270-01	Gear W/Tin Coating for Waterbased Materials (optional)	2
6	76272-00	O-Ring, Solvent Proof (1 Required)	1
7	N/A	Housing, Lower	1
8	77214-00	RF 1 Fiber Optic Flow Meter Assembly ( <i>Less Fittings</i> )	1
9	LSF10033-00	Fitting, 3/8" AN x 3/8" OD (Optional)	1
10	77104-00	Fitting, 3/8" AN x 3/8" NPSM (m) (Optional)	1
	77105-00	Fitting, 3/8" AN x 1/4" NPSM (m) (Optional)	1
11	77215-00	Receiver	1
12	77452-00	Cable (Receiver to Readout)	1
13	<b>See Table A</b>	Fiber Optic Cables	<b>"C"</b>
14	13521-01	Ferrule Nut, Nylon	2

TABLE A - FIBER OPTIC CABLE		
Part #	"C"	Cable Length
77786-10	SMC-424-9	10 Ft.
77786-15	SMC-424-5	15 Ft.
77786-25	SMC-424-6	25 Ft.
77786-50	SMC-424-2	50 Ft.
77786-65	SMC-424	65 Ft.
77786-75	SMC-424-7	75 Ft.
77786-100	SMC-424-1	100 Ft.

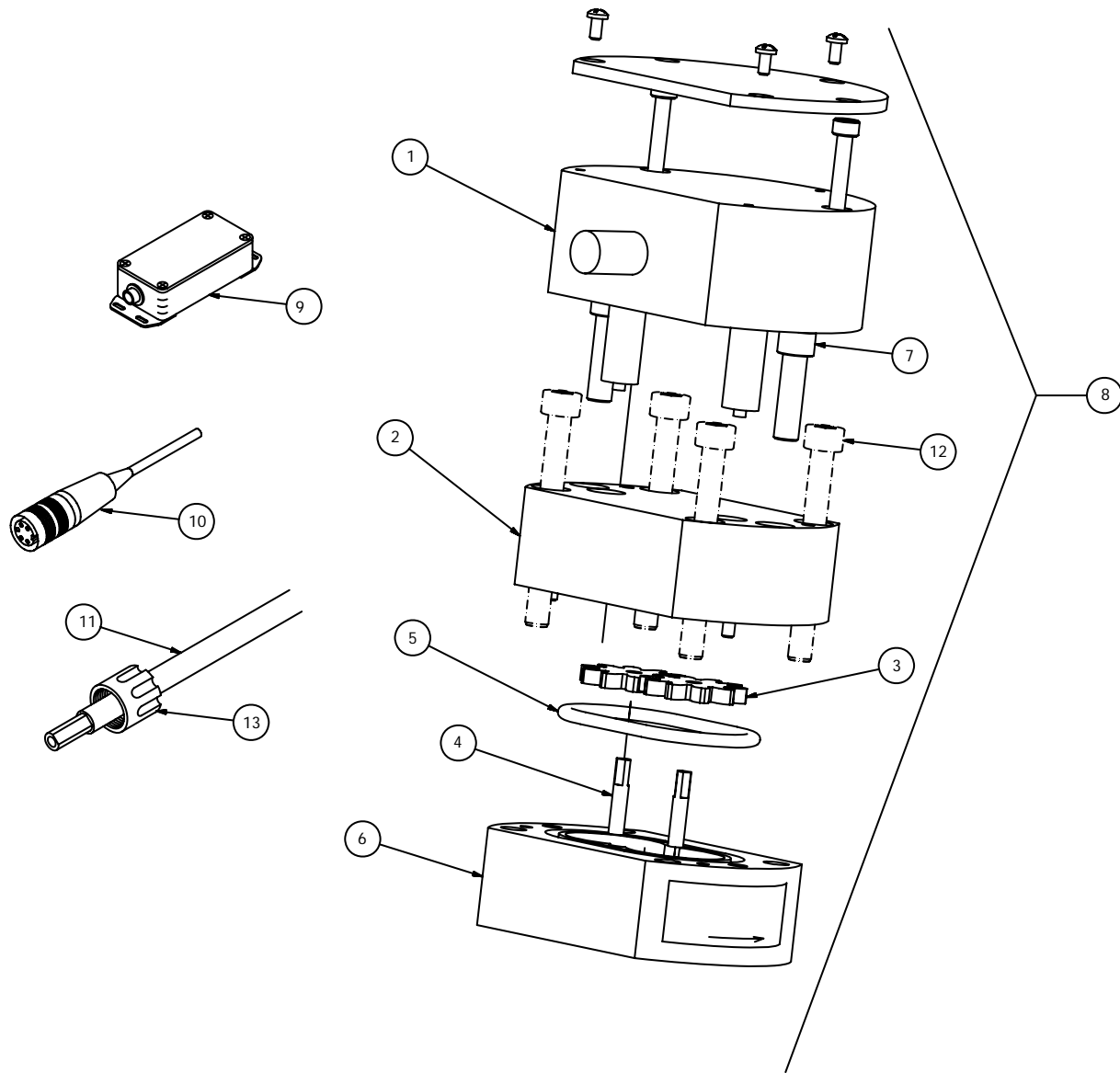

Figure 19: A11516-XX RF 1 Fiber Optic Flow Meter Kit (Used With MCV-2 Color Changer)



**A11516-XX RF 1 FIBER OPTIC FLOW METER KIT  
(USED WITH MCV-2 COLOR CHANGER) - PARTS LIST  
(Figure 19)**

Item #	Part #	Description	Qty
1	77355-00	Transmitter	1
2	N/A	Housing, Upper	1
3	76270-00	Gear	2
	76270-01	Gear W/Tin Coating for Waterbased Materials (Optional)	2
4	79271-00	Shaft	2
5	76272-00	O-Ring, Solvent Proof	1
6	N/A	Housing, Lower	1
7	7959-00	Screw, Shc., 1/4-20 X 3/4 Lg.	6
8	A10830-00	Flow Meter Assembly, Bottom Entry	1
9	77215-00	Receiver	1
10	77452-00	Cable (Receiver to Readout)	1
11	<b>See Table B</b>	Fiber Optic Cables	<b>"C"</b>
12	A10468-50	Screw, SHC., Included with A10720	4
13	13521-01	Ferrule Nut, Nylon	2

**TABLE B - FIBER OPTIC CABLE**

Part #	"C"	Cable Length
A11516-10	SMC-424-9	10 Ft.
A11516-15	SMC-424-5	15 Ft.
A11516-25	SMC-424-6	25 Ft.
A11516-50	SMC-424-2	50 Ft.
A11516-65	SMC-424	65 Ft.
A11516-75	SMC-424-7	75 Ft.
A11516-100	SMC-424-1	100 Ft.

---

# WARRANTY POLICIES

---

## LIMITED WARRANTY

ITW Ransburg will replace or repair without charge any part and/or equipment that fails within the specified time (see below) because of faulty workmanship or material, provided that the equipment has been used and maintained in accordance with ITW Ransburg's written safety and operating instructions, and has been used under normal operating conditions. Normal wear items are excluded.

**THE USE OF OTHER THAN ITW RANSBURG APPROVED PARTS VOIDS ALL WARRANTIES.**

**SPARE PARTS:** One hundred and eighty (180) days from date of purchase, except for rebuilt parts (any part number ending in "R") for which the warranty period is ninety (90) days.

**EQUIPMENT:** When purchased as a complete unit, (i.e., guns, power supplies, control units, etc.), is one (1) year from date of purchase. **WRAPPING THE APPLICATOR, ASSOCIATED VALVES AND TUBING, AND SUPPORTING HARDWARE IN PLASTIC, SHRINK-WRAP, OR ANY OTHER NON-APPROVED COVERING, WILL VOID THIS WARRANTY.**

ITW RANSBURG'S ONLY OBLIGATION UNDER THIS WARRANTY IS TO REPLACE PARTS THAT HAVE FAILED BECAUSE OF FAULTY WORKMANSHIP OR MATERIALS. THERE ARE NO IMPLIED WARRANTIES NOR WARRANTIES OF EITHER MERCHANTABILITY OR FITNESS FOR A PARTICULAR PURPOSE. ITW RANSBURG ASSUMES NO LIABILITY FOR INJURY, DAMAGE TO PROPERTY OR FOR CONSEQUENTIAL DAMAGES FOR LOSS OF GOODWILL OR PRODUCTION OR INCOME, WHICH RESULT FROM USE OR MISUSE OF THE EQUIPMENT BY PURCHASER OR OTHERS.

### EXCLUSIONS:

If, in ITW Ransburg's opinion the warranty item in question, or other items damaged by this part was improperly installed, operated or maintained, ITW Ransburg will assume no responsibility for repair or replacement of the item or items. The purchaser, therefore will assume all responsibility for any cost of repair or replacement and service related costs if applicable.

# APPENDIX

## PAINT AND SOLVENT SPECIFICATIONS

	REA™ VECTOR™ EFM™ EVOLVER™	REM™ / M90™	NO. 2 HAND GUN	TURBODISK™	AEROBELL® II*** AEROBELL® AEROBELL® 33 RMA™-101
RECOMMENDED VISCOSITY USING A ZAHN NO. 2	18 TO 30 SEC	18 TO 30 SEC	20 TO 60 SEC	20 TO 60 SEC	20 TO 60 SEC
PAINT ELECTRICAL RESISTANCE**	.1 MΩ TO ∞	.1 MΩ TO ∞	.1 TO 1 MΩ	.1 MΩ TO ∞	.1 MΩ TO ∞
RECOMMENDED DELIVERY (UP TO)	1000 cc/min	1500 cc/min	180 cc/min	1000 cc/min	500 cc/min

### GUIDE TO USABLE SOLVENT SELECTION

Chemical Name	Common Name	Category	Flash Point†† (TCC)	*CAS Number	Evap. Rate†	Elec. Res.**
DICHLOROMETHANE	Methylene Chloride	Chlorinated Solvents		75-09-2	14.5	HIGH
VM & P NAPHTHA	Naptha	Aliphatic Hydrocarbons	65°F	8030-30-6	10	HIGH
ACETONE		Ketones	-18°F	67-64-1	5.6	LOW
METHYL ACETATE		Esters	90°F	79-20-9	5.3	LOW
BENZENE		Aromatic Hydrocarbons	12°F	71-43-2	5.1	HIGH
ETHYL ACETATE		Esters	24°F	141-78-6	3.9	MEDIUM
2-BUTANONE	MEK	Ketones	16°F	78-93-3	3.8	MEDIUM
ISO-PROPYL ACETATE		Esters	35°F	108-21-4	3.4	LOW
ISOPROPYL ALCOHOL	IPA	Alcohols	53°F	67-63-0	2.5	LOW
2-PENTANONE	MPK	Ketones	104°F	107-87-9	2.5	MEDIUM
METHANOL	Methyl Alcohol	Alcohols	50°F	67-56-1	2.1	LOW
PROPYL ACETATE	n-Propyl Acetate	Esters	55°F	109-60-4	2.1	LOW
TOLUOL	Toluene	Aromatic Hydrocarbons	48°F	108-88-3	1.9	HIGH
METHYL ISOBUTYL KETONE	MIBK	Ketones	60°F	108-10-1	1.6	MEDIUM
ISOBUTYLACETATE		Esters	69°F	110-19-0	1.5	LOW
ETHANOL	Ethyl Alcohol	Alcohols		64-17-5	1.4	LOW
<b>BUTYL ACETATE</b>		<b>Esters</b>	<b>78°F</b>	<b>123-86-4</b>	<b>1.0</b>	<b>LOW</b>
ETHYLBENZENE		Aromatic Hydrocarbons	64°F	100-41-4	.89	HIGH
1-PROPANOL	n-Propyl Alcohol	Alcohols	74°F	71-23-8	.86	LOW
2-BUTANOL	sec.-Butyl Alcohol	Alcohols	72°F	78-92-2	.81	LOW
XYLOL	Xylene	Aromatic Hydrocarbons	79°F	1330-02-07	.80	HIGH
AMYLACETATE		Esters	106°F	628-63-7	.67	MEDIUM
2-METHYLPROPANOL	iso-Butyl Alcohol	Alcohols	82°F	78-83-1	.62	LOW
METHYL AMYL ACETATE		Esters	96°F	108-84-9	.50	LOW
5-METHYL-2-HEXANONE	MIAK	Ketones	96°F	110-12-3	.50	MEDIUM
1-BUTANOL	n-Butyl Alcohol	Alcohols	95°F	71-36-3	.43	LOW
2-ETHOXYETHANOL		Glycol Ethers	164°F	110-80-5	.38	LOW
2-HEPTANONE	MAK	Ketones	102°F	110-43-0	.40	MEDIUM
CYCLOHEXANONE		Ketones	111°F	108-94-1	.29	MEDIUM
AROMATIC-100	SC#100	Aromatic Hydrocarbons	111°F		.20	HIGH
DIISOBUTYL KETONE	DIBK	Ketones	120°F	108-83-8	.19	MEDIUM
1-PENTANOL	Amyl Alcohol	Alcohols		71-41-0	.15	LOW
DIACETONE ALCOHOL		Ketones	133°F	123-42-2	.12	LOW
2-BUTOXYETHANOL	Butyl Cellosolve	Glycol Ethers	154°F	111-76-2	.07	LOW
CYCLOHEXANOL		Alcohols	111°F	108-93-0	.05	LOW
AROMATIC-150	SC#150	Aromatic Hydrocarbons	149°F		.004	HIGH
AROMATIC-200		Aromatic Hydrocarbons	203°F		.003	HIGH

\* CAS Number: Chemical Abstract Service Number.

\*\* Electrical Resistance using the ITW Ransburg Meter.

\*\*\* Solvent Base Configuration Only.

† Information Obtained From: <http://solvdb.ncms.org>

†† The lowest temperature at which a volatile fluid will ignite.

**Evaporation Rate is Based Upon Butyl Acetate Having a Rate of 1.0**

© 05/2006 Illinois Tool Works Inc. All rights reserved.

**NOTE:** Chart provides resistance and control information that we feel is necessary when using ITW Ransburg equipment.

VISCOSITY CONVERSION CHART																		
Poise	Centipoise	DuPont Parlin 7	DuPont Parlin 10	Fisher 1	Fisher 2	Ford Cup 3	Ford Cup 4	Gardner - Holdt Bubble	Gardner - Lithographic	Krebs Unit KU	Saybolt Universal SSU	Zahn 1	Zahn 2	Zahn 3	Zahn 4	Zahn 5	Sears Craftsman Cup	Din Cup 4
.1	10	27	11	20			5	A-4			60	30	16					10
.15	15	30	12	25			8	A-3			80	34	17					11
.2	20	32	13	30	15	12	10				100	37	18					12
.25	25	37	14	35	17	15	12	A-2			130	41	19					13
.3	30	43	15	39	18	19	14	A-1			160	44	20					14
.4	40	50	16	50	21	25	18	A			210	52	22				19	15
.5	50	57	17		24	29	22			30	260	60	24				20	16
.6	60	64	18		29	33	25	B		33	320	68	27				21	18
.7	70		20		33	36	28			35	370		30				23	21
.8	80		22		39	41	31	C		37	430		34				24	23
.9	90		23		44	45	32			38	480		37	10			26	25
1.0	100		25		50	50	34	D		40	530		41	12	10		27	27
1.2	120		30		62	58	41	E		43	580		49	14	11		31	31
1.4	140		32			66	45	F		46	690		58	16	13		34	34
1.6	160		37				50	G		48	790		66	18	14		38	38
1.8	180		41				54		000	50	900		74	20	16		40	43
2.0	200		45				58	H		52	1000		82	23	17	10	44	46
2.2	220						62	I		54	1100			25	18	11		51
2.4	240						65	J		56	1200			27	20	12		55
2.6	260						68			58	1280			30	21	13		58
2.8	280						70	K		59	1380			32	22	14		63
3.0	300						74	L		60	1475			34	24	15		68
3.2	320							M			1530			36	25	16		72
3.4	340							N			1630			39	26	17		76
3.6	360							O		62	1730			41	28	18		82
3.8	380										1850			43	29	19		86
4.0	400							P		64	1950			46	30	20		90
4.2	420										2050			48	32	21		95
4.4	440							Q			2160			50	33	22		100
4.6	460							R		66	2270			52	34	23		104
4.8	480								00	67	2380			54	36	24		109
5.0	500							S		68	2480			57	37	25		112
5.5	550							T		69	2660			63	40	27		124
6.0	600							U		71	2900			68	44	30		135
7.0	700									74	3375				51	35		160
8.0	800								0	77	3380				58	40		172
9.0	900							V		81	4300				64	45		195
10.0	1000							W		85	4600					49		218
11.0	1100									88	5200					55		
12.0	1200									92	5620					59		

<b>VISCOSITY CONVERSION CHART (Continued)</b>																		
Poise	Centipoise	DuPont Parlin 7	DuPont Parlin 10	Fisher 1	Fisher 2	Ford Cup 3	Ford Cup 4	Gardner - Holdt Bubble	Gardner - Lithographic	Krebs Unit KU	Saybolt Universal SSU	Zahn 1	Zahn 2	Zahn 3	Zahn 4	Zahn 5	Sears Craftsman Cup	Din Cup 4
13.0	1300							X		95	6100							
14.0	1400									96	6480							
15.0	1500									98	7000							
16.0	1600									100	7500							
17.0	1700									101	8000							
18.0	1800							Y			8500							
19.0	1900										9000							
20.0	2000									103	9400							
21.0	2100										9850							
22.0	2200										10300							
23.0	2300							Z	2	105	10750							
24.0	2400									109	11200							
25.0	2500							Z-1		114	11600							
30.0	3000									121	14500							
35.0	3500							Z-2	3	129	16500							
40.0	4000									133	18500							
45.0	4500							Z-3		136	21000							
50.0	5000										23500							
55.0	5500										26000							
60.0	6000							Z-4	4		2800							
65.0	6500										30000							
70.0	7000										32500							
75.0	7500										35000							
80.0	8000										37000							
85.0	8500										39500							
90.0	9000										41000							
95.0	9500										43000							
100.0	10000							Z-5	5		46500							
110.0	11000										51000							
120.0	12000										55005							
130.0	13000										60000							
140.0	14000										65000							
150.0	15000							Z-6			67500							
160.0	16000										74000							
170.0	17000										83500							
180.0	18000										83500							
190.0	19000										88000							
200.0	20000										93000							
300.0	30000										140000							

**Note:** All viscosity comparisons are as accurate as possible with existing information. Comparisons are made with a material having a specific gravity of 1.0.

©05/2004 Illinois Tool Works Inc. All rights reserved.

<b>VOLUMETRIC CONTENT OF HOSE OR TUBE (English Units)</b>							
<b>I.D. (inches)</b>	<b>cc/ft.</b>	<b>Cross Section (sq. in.)</b>	<b>Length</b>				
			<b>5ft. (60")</b>	<b>10ft. (120")</b>	<b>15ft. (180")</b>	<b>25ft. (300")</b>	<b>50ft. (600")</b>
1/8	2.4	.012	.003 gal. .4 fl. oz.	.006 gal. .8 fl. oz.	.010 gal. 1.2 fl. oz.	.016 gal. 2.0 fl. oz.	.032 gal. 4.1 fl. oz.
3/16	5.4	.028	.007 gal. .9 fl. oz.	.014 gal. 1.8 fl. oz.	.022 gal. 2.8 fl. oz.	.036 gal. 4.6 fl. oz.	.072 gal. 9.2 fl. oz.
1/4	9.7	.049	.013 gal. 1.6 fl. oz.	.025 gal. 3.3 fl. oz.	.038 gal. 4.9 fl. oz.	.064 gal. 8.2 fl. oz.	.127 gal. 16.3 fl. oz.
5/16	15.1	.077	.020 gal. 2.5 fl. oz.	.040 gal. 5.1 fl. oz.	.060 gal. 7.6 fl. oz.	.100 gal. 12.7 fl. oz.	.199 gal. 25.5 fl. oz.
3/8	21.7	.110	.029 gal. 3.7 fl. oz.	.057 gal. 7.3 fl. oz.	.086 gal. 11.0 fl. oz.	.143 gal. 18.4 fl. oz.	.287 gal. 36.7 fl. oz.
1/2	38.6	.196	.051 gal. 6.5 fl. oz.	.102 gal. 13.1 fl. oz.	.153 gal. 19.6 fl. oz.	.255 gal. 32.6 fl. oz.	.510 gal. 65.3 fl. oz.

<b>VOLUMETRIC CONTENT OF HOSE OR TUBE (Metric Units)</b>							
<b>I.D. (mm)</b>	<b>cc/m</b>	<b>Cross Section (mm<sup>2</sup>)</b>	<b>Length</b>				
			<b>1.5m</b>	<b>3.0m</b>	<b>4.5m</b>	<b>6.0m</b>	<b>7.5m</b>
3.6	10.2	10.2	15.3 cc	30.5 cc	45.8 cc	61.1 cc	76.3 cc
5.6	24.6	24.6	36.9 cc	73.9 cc	110.8 cc	147.8 cc	184.7 cc
6.8	36.3	36.3	54.5 cc	109.0 cc	163.4 cc	217.9 cc	272.4 cc
8.8	60.8	60.8	91.2 cc	182.5 cc	273.7 cc	364.9 cc	456.2 cc

© 05/2004 Illinois Tool Works Inc. All rights reserved.

---

# MANUAL CHANGE SUMMARY

This manual was published to supercede Service Manual **FM-00-02.4** to make the following changes:

1. Added in "Specifications - System - Fiber Optic Link - Available Lengths - 10 Ft." in the "Introduction" section.
2. New "Figure 3 - Fiber Optic Cable Assembly" in the "Introduction" section.
3. Added "Caution - Service" in the "Operation" section.
4. New "Figure 18 - 77786-XX RF 1 Fiber Optic Flow Meter Kit" in the "Parts Identification" section.
5. Revised "Note - Service" in the "Operation" section.
6. New "Figure 18 - 77786-XX RF 1 Fiber Optic Flow Meter Kit" in the "Parts Identification" section.
7. Added "Part #76270-01 - Gear W/Tin Coating for Waterbased Materials (Optional)" in the "77786-XX RF 1 Fiber Optic Flow Meter Kit - Parts List" in the "Parts Identification" section.
8. "Table A - Fiber Optic Cable - added Part #77786-10" in the "Parts Identification" section.
9. New "Figure 19 - A11516-XX RF 1 Fiber Optic Flow Meter Kit (Used W/MCV-2 Color Changer)" in the "Parts Identification" section.
10. Added "Part #76270-01 - Gear W/Tin Coating for Water Based Materials (Optional)" - in the "Parts Identification" section.
11. "Table B - Fiber Optic Cable - added Part #A11516-10" in the "Parts Identification" section.

### **Manufacturing**

1910 North Wayne Street  
Angola, Indiana 46703-9100  
Telephone: 260/665-8800  
Fax: 260/665-8516

### **Technical/Service Assistance**

Automotive Assembly and Tier I  
Industrial Systems  
Ransburg Guns

Telephone: 800/ 626-3565 Fax: 419/ 470-2040  
Telephone: 800/ 233-3366 Fax: 419/ 470-2071  
Telephone: 800/ 233-3366 Fax: 419/ 470-2071

**Technical Support Representative will direct you to the appropriate telephone number for ordering Spare Parts.**

