

HVLP CUP PRESSURE CONTROL ASSEMBLY AND KK-4980 CUP REGULATOR KIT

SPECIFICATIONS

Regulator: Max. 125 psig inlet air pressure
0 to 8 psig regulated air pressure.

Safety Valve: 18 psig blow-off air pressure

DESCRIPTION

The cup pressure control assembly will allow the painter to adjust the optimum paint flow to achieve the best finish by use of an air pressure regulator. The regulator gauge shows the pressure in the paint cup and allows the painter to return to that pressure when this type of paint is used again.

The cup check valve will prevent the cup from losing pressure. The check valve also prevents paint from backing up into the air tube if the cup is tilted. The poppet stem in the cup lid allows the painter to manually relieve the cup pressure.

The regulator assembly can be removed from the gun without the use of tools before the gun is placed in the gun washer.

INSTALLATION

Refer to Figure 1. Push in the quick connect button and connect the fluid control to the gun handle. Connect the air tube to the paint cup. For complete assembly, see Page 2.

OPERATION

WARNING

Risk of bursting. Do not exceed the maximum pressure noted on the regulator and paint cup.

WARNING

If the safety valve does not work properly, over-pressurization may occur, causing paint cup rupture or an explosion. Occasionally pull the ring on the safety valve to make sure that the safety valve operates freely. If the valve is stuck or does not operate smoothly, it must be replaced with the same type of valve.

1. Turn the cup regulator knob completely counter-clockwise until it stops. The air flow to the paint cup is now shut off.
2. Slowly increase the air pressure to the spray gun. Do not exceed the recommended inlet pressure for the spray gun being used.
3. Very slowly turn the cup regulator knob clockwise while pulling the gun trigger. Adjust the cup pressure for the proper paint flow. It is normal for the gauge pressure reading to be higher when the gun trigger is released.
4. If you want to decrease the paint flow, turn the regulator knob counterclockwise. PUSH DOWN THE CHECK VALVE POPPET STEM TO RELIEVE THE CUP PRESSURE. THE REGULATOR GAUGE WILL NOW SHOW THE ACTUAL CUP PRESSURE. The cup lid has a check valve that prevents the cup from losing pressure until the check valve is opened manually by pushing the poppet stem down.

Note

For the gauge to read the correct cup pressure, always approach the desired pressure from a lower pressure. When reducing from a higher to a lower setting, first reduce to some pressure less than desired, then increase to desired pressure.

CAUTION

Damage to regulator, gauge, and safety valve will result if paint or solvent is allowed to flow into these parts. Do not clean these parts with solvent. Always remove the regulator assembly (quick disconnect, regulator, gauge, safety valve, manifold, and tube) from the gun before cleaning the gun.

CAUTION

The paint cup is pressurized. Relieve the cup pressure before opening the cup. Before removing the cup lid, turn the cup regulator knob counterclockwise to shut off air to the paint cup. Push down on the check valve poppet stem to relieve the cup pressure. If this procedure is not followed, paint may be forced up the air tube.

MAINTENANCE (Refer to Figure 1)

Regulator Assembly: Before cleaning the gun, the regulator assembly must be removed or damage may result from the solvent. Shut off air to the gun and pull off the air tube at the cup lid. Push the button on the quick disconnect and remove regulator assembly from gun.

Quick Disconnect (Regulator): This quick disconnect does not have an automatic shut off. ALWAYS SHUT OFF AIR SUPPLY TO GUN BEFORE PUSHING THE QUICK DISCONNECT'S RELEASE BUTTON. To avoid possible damage to o-ring, do not assemble the quick connect together under air flow conditions. Do not allow solvent to contact o-ring, some solvents may cause the o-ring to swell and cause difficult reassembly of the quick connect. Replacement o-rings (20-3515-K5) have been included with this kit.

Check Valve: After each use, clean the check valve with solvent. It cannot be disassembled. Do not direct air pressure higher than 15 psi through or at the check valve. This may damage the valve. The check valve ball and seat must be free of dried paint for it to seal properly.

Safety Valve: Prevent solvent and paint from entering the safety valve. Occasionally pull ring to make sure it operates freely. If it is stuck or does not operate smoothly, it must be replaced with the same type of valve.

Cup Pressure Release (Poppet Stem): When the poppet stem is pushed down, it is normal for a small amount of paint mist to discharge from the poppet stem hole if the check valve has become wet with paint. To prevent sticking, the poppet stem and hole must be cleaned with solvent after each use.

ASSEMBLY

For assembly of KK-4980 and part numbers, refer to Figures 2 and 3.

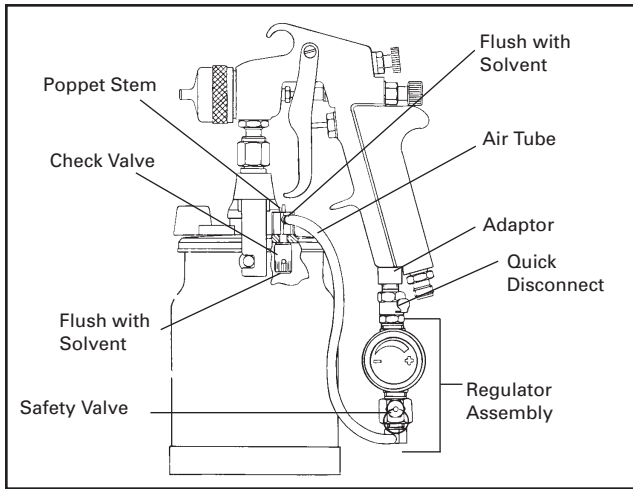

FIGURE 1

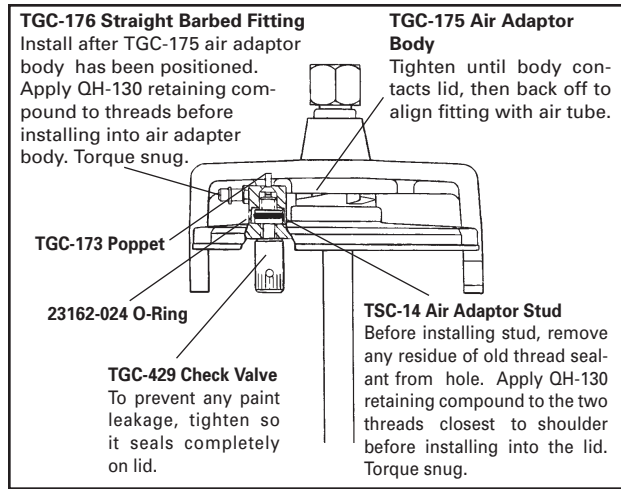
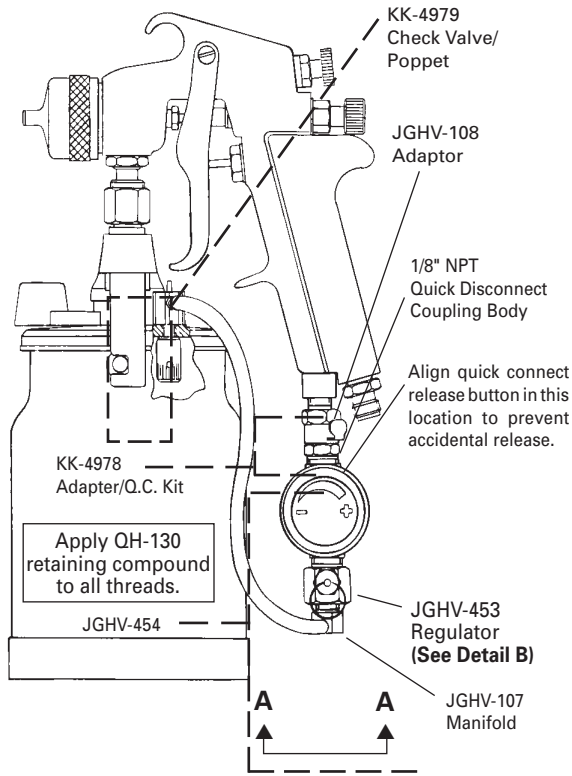
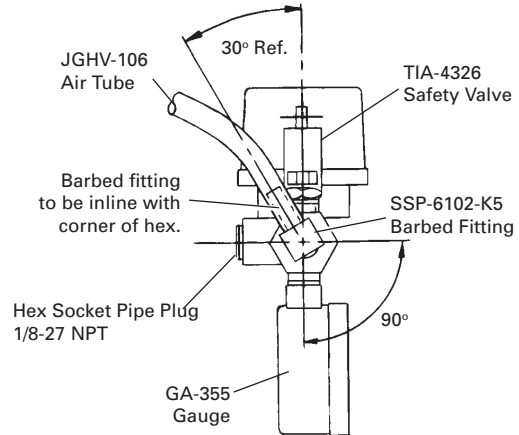

FIGURE 2 CHECK VALVE AND PRESSURE RELEASE (INCLUDED WITH KK-4979)



GUN, CUP AND REGULATOR ASSEMBLY



VIEW A-A - POSITION OF FITTINGS (PARTS INCLUDED WITH JGHV-454 & JGHV-107)

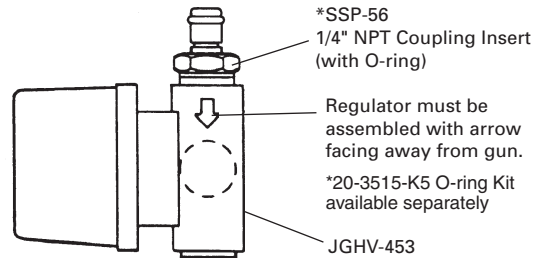

DETAIL B REGULATOR AND COUPLING INSERT

FIGURE 3

WARRANTY

This product is covered by DeVilbiss' 1 Year Limited Warranty.

DeVilbiss Sales and Service: www.devilbiss.com



U.S.A./Canada Customer Service
195 Internationale Blvd.
Glendale Heights, IL 60139
630-237-5000

Toll Free Customer Service
and Technical Support
800-992-4657

Toll Free Fax
888-246-5732