

# OPERATOR'S MANUAL

INCLUDING: OPERATION, INSTALLATION & MAINTENANCE  
INCLUDE MANUAL: S-1099 GENERAL INFORMATION MANUAL (PN 876018)

812300  
812304

RELEASED: 10-4-99  
REVISED: 9-10-01  
(REV. H)

2" AIR MOTOR  
2:1 RATIO

## 812300 and 812304 2" DIFFERENTIAL TRANSFER PUMP



READ THIS MANUAL CAREFULLY BEFORE INSTALLING,  
OPERATING OR SERVICING THIS EQUIPMENT.

It is the responsibility of the employer to place this information in the hands of the operator. Keep for future reference.

### SERVICE KITS

- Use only genuine Binks replacement parts to assure compatible pressure rating and longest service life.
- **861034** for repair of air motor section.
- **861089** for repair of lower pump end.

### SPECIFICATIONS

Model Series	81230X
System Type	Air Operated, Double Acting Pump
Ratio	2:1
Air Motor	842004
Motor Diameter	2" (50.8 mm)
Stroke (Double Acting)	6" (152.4 mm)
Air Inlet (female)	1/4 - 18 N.P.T.F.
Lower Pump End	
models 812300	873009
models 812304	873200
Material Inlet	
models 812300	immersed
models 812304 (female)	1 - 11-1/2 N.P.T.F. - 1
Material Outlet (female)	1/2 - 14 N.P.T.F. - 1

### PERFORMANCE

Air Inlet Pressure Range	0 - 150 p.s.i. (0 - 10.3 bar)
Fluid Pressure Range	0 - 300 p.s.i. (0 - 20.7 bar)
Max. Rec'd Cycles / Minute	120
Displacement In <sup>3</sup> Per Cycle	8.0
Volume / Cycle	4.4 oz. (131 ml)
Cycles Per Gallon	28.8
Flow @ 120 Cycles / Minute	4.2 g.p.m. (15.8 l.p.m.)
Noise Level @ 90 p.s.i. - 40 c.p.m.	81 db(A) <sup>①</sup>

① The pump sound pressure level has been updated to an Equivalent Continuous Sound Level ( $L_{Aeq}$ ) to meet the intent of ANSI S1.13-1971, CAGI-PNEUROP S5.1 using four microphone locations.

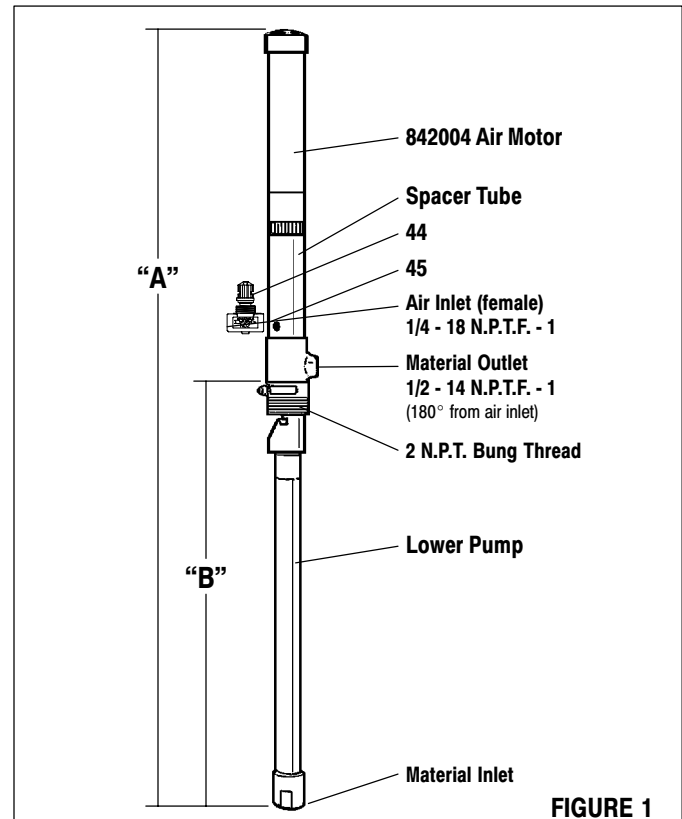

FIGURE 1

MODELS	"A"	"B"
812300	52-7/8" (1343 mm)	33-3/4" (857 mm)
812304	41-1/2" (1054 mm)	22-3/8" (568 mm)

### OPERATING AND SAFETY PRECAUTIONS

- Refer to General Information sheet for additional safety precautions and important information.

**BINKS**®

North American Office  
ITW Industrial Finishing  
195 Internationale Blvd  
Glendale Heights, IL 60139  
Tel. 630-237-5000 Fax 630-237-5011

International Office  
ITW Industrial Finishing  
Ringwood Road, Bournemouth  
Dorset, BH11 9LH, England  
Tel. 0 1202 571111 Fax 0 1202 593883

---

---

## PLACING INTO SERVICE

---

---

### AIR AND LUBE REQUIREMENTS

---

- Do not operate pump continuously at speeds in excess of 75 cycles per minute.
- Excessive air pressure will shorten the life of the pump.
- For maximum operating efficiency, maintain the following air supply specifications.
- Use an air regulator to control operating pressure and cycle rate.
- It is recommended that an oiler be installed in the airline as close as possible to the pump. This increases the service life of the pump by reducing wear of the air motor's internal parts.
- Lack of or an excessive amount of lubrication will affect the performance and life of this pump. Use the recommended lubricants.
  - AIR PRESSURE - Up to 150 p.s.i. (10 bar)
  - AIR FILTRATION - 50 micron
  - LUBRICATED AIR SUPPLY

---

### INSTALLATION

---

#### FLUSH PUMP

1. Connect fluid hose to pump outlet and be sure all fittings are tight.
  2. Turn air regulator knob counter-clockwise until it turns freely.
  3. Pump has been tested in oil and a small amount remains for protection against rusting. Immerse lower pump end in compatible solvent.
  4. Connect air hose coupler to connector on F-R-L.
  5. Turn air regulator knob clockwise until air motor starts operating.
  6. Flush pump with oil.
  7. Disconnect air supply from air motor.
- CAUTION: Solvent used for flushing may not be compatible with material being pumped. If this is the case, flush again with a compatible solvent.
  - If pump does not function properly, disconnect air and relieve all pressure. Refer to Trouble Shooting.

---

### GENERAL DESCRIPTION

---

The Binks 2" differential 2:1 ratio transfer pumps have been designed for the application and transfer of a wide range of corrosive and non-corrosive materials. Refer to the part's list on page 5 for manufactured materials and packings available. These pumps may be directly mounted in the 2" bung of a standard drum or when using a 873184 mounting bracket, the pump can be mounted on the wall or in an open head drum.

#### AIR MOTOR

The 2" pump uses a differential, double acting style of air motor.

#### SPACER SECTION

The air motor is connected to the lower pump end by a spacer tube, this protects the air motor section from possible contamination due to normal wear and eventual leakage of material past the upper material piston seals.

$$\text{PUMP RATIO X INLET PRESSURE TO PUMP MOTOR} = \text{MAXIMUM PUMP FLUID PRESSURE}$$

Pump ratio is an expression of the relationship between the pump motor area and the lower pump end area. EXAMPLE: When 150 p.s.i. (10.3 bar) inlet pressure is supplied to the motor of a 6:1 ratio pump it will develop a maximum of 750 p.s.i. (52 bar) fluid pressure (at no flow) - as the fluid control is opened, the flow rate will increase as the motor cycle rate increases to keep up with the demand.

#### LOWER PUMP SECTION

Models covered by this manual have either threaded or unthreaded material inlets.

---

### MAINTENANCE

---

The basic pump consists of two major components: 1. Air Motor, 2. Lower Pump. The air motor is removable and is to be serviced separately. Refer to air motor manual for service and parts. Disassembly should be done on a clean work bench.

- Periodically flush entire pump system with a solvent that is compatible with the material being pumped.
- Refer to disassembly procedures of air motor for correct breakdown.
- Before reassembling, lubricate parts where required. When reassembling "O" rings or parts adjacent to "O" rings, care must be exercised to prevent damage to "O" rings and "O" ring groove surfaces.
- SERVICING. Disconnect air lines and carefully bleed the pressure off the system before servicing or cleaning pump, or removing fluid hose or gun.

---

### TROUBLE SHOOTING

---

#### Pump continually cycles.

- Check for empty material supply. Disconnect the air (from the pump) replenish material supply.
- Check to see if the connecting rod has disassembled from the mating rod. See assembly of lower pump end (figure 4).
- The ball may be wedged or sticking open in the foot valve body. NOTE: Replace the ball or the foot valve if either are damaged.
- Check for worn or damaged (9) upper piston.

#### Material on one stroke only (fast downstroke).

- The ball in the foot valve may not be checking or sealing properly. Remove the ball from foot valve and inspect. If the ball or foot valve is damaged replace with new parts. If the ball or foot valve is not damaged, thoroughly clean both parts and reassemble (see lower pump end instructions).

#### Material on one stroke only (fast upstroke).

- Check for worn or damaged (37) lower material piston. Replace piston (see lower pump end instructions)(see figure 7).

#### Material leakage out the top of the pump body.

- Check for worn or damaged (9) upper piston. See lower pump end instructions and replace the upper piston.
- Remove (41) ball from the (42 or 43) foot valve body. Thoroughly clean and replace (see figure 7).

#### Air leakage out of the exhaust holes (see Air Motor Instructions).

- Check to see if the (9) valve plate is loose or has disassembled from the (11) spacer.
- Check for worn or damaged (10) piston.
- Check for worn or damaged (19) "O" ring.
- Check for worn or warped (9) valve plate.
- Worn or damaged (14) "O" ring. Replace (14) "O" ring.

## PUMP SERVICE PROCEDURES

### PUMP DISASSEMBLY

Refer to Figure 3.

NOTE: All threads are right hand.

CAUTION: Do not clamp the pump tightly.

1. Thread a 1/2" nipple into the material outlet.
2. Place the 2" differential pump assembly in a vise as shown. Rotate the pump assembly so that the 1/2" nipple is resting against the vise.

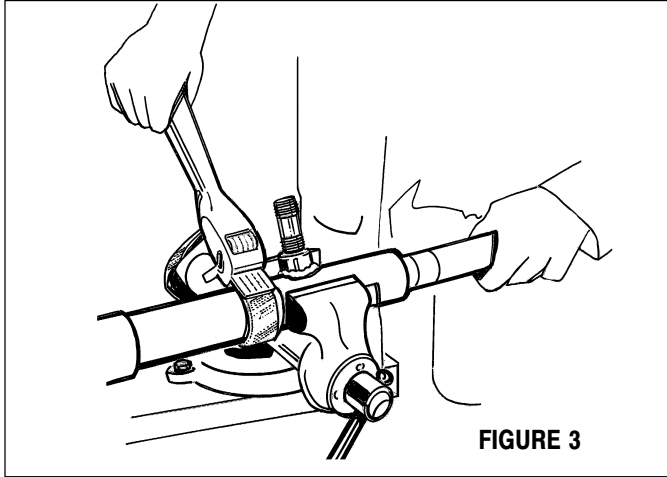

FIGURE 3

3. Unthread the air motor from the material outlet body by using a strap wrench on the air motor separating tube.
4. Push the connecting rod, in the lower pump assembly, to one side and pull down until the air motor separates from the lower pump assembly.

5. The pump is now in two assemblies: air motor and lower pump assembly.

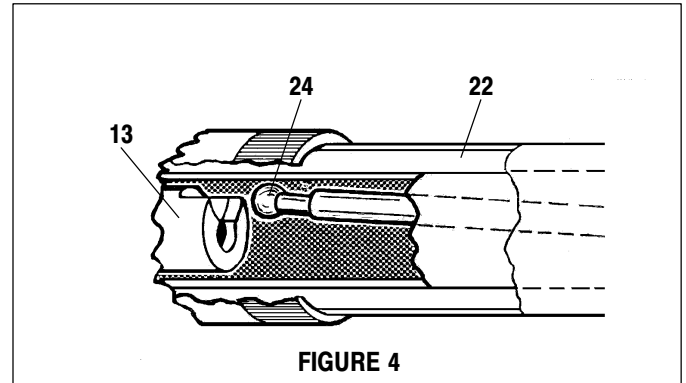

FIGURE 4

### PUMP REASSEMBLY

Refer to Figure 3.

1. Place the 2" air motor in a vise with the needle valve or pipe nipple resting against the jaws of the vise, as shown.
2. Insert the (24) tip of the lower pump assembly into the (22) separating tube of the air motor.
3. Insert the (24) tip of the lower pump assembly through the outside edge of the slot in the (13) plunger tip, center the (24) tip in the (13) plunger tip and pull out until the (24) tip is retained.
4. Thread the air motor into the material outlet body and tighten by using a strap wrench on the air motor (22) separating tube.

## 2" AIR MOTOR SERVICE PROCEDURES

### 2" AIR MOTOR DISASSEMBLY

Refer to Figure 5.

1. Place the air motor in the vise with a needle valve or a 1/4" pipe nipple resting against the jaws of the vise, as shown.

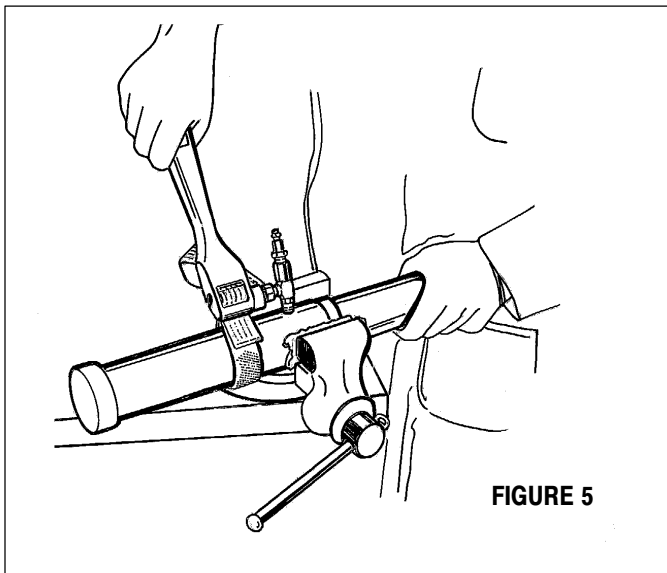

FIGURE 5

NOTE: All threads are right hand.

2. Place a strap wrench around the (1) cap and remove the cap. NOTE: If the (6) cylinder comes off with (1) cap, place the cap in a vise and use a strap wrench around the cylinder and unscrew from cap. NOTE: Do not squeeze or use pipe wrench on (6).
3. Place a strap wrench around the (6) cylinder and unscrew and remove the cylinder.
4. Pull the (7) assembly and (15) plunger out of the (18) body and lay aside.
5. Remove the (17) spring and (16) "O" ring from the (18) body.
6. Place the (18) body in the vise and loosen the (21) lock ring with a strap wrench.
7. Place a strap wrench around the (22) separating tube and unthread.
8. Remove the (20) washer and (19) "O" ring from the (18) body.
9. Clamp the flats of the (7) piston and spacer assembly in the vise. Remove the plunger tip from the (7) spacer and piston assembly. NOTE: Do not remove the (13) plunger tip from the (15) plunger, unless replacing parts.
10. Remove the (12) gasket from the (13) plunger tip. NOTE: Do not mar or damage o.d. of (15) plunger.
11. Remove the three (8) screws from the spacer and piston assembly.
12. Remove the (9) valve plate and (11) valve spacer.

## 842004 2" AIR MOTOR PARTS LIST

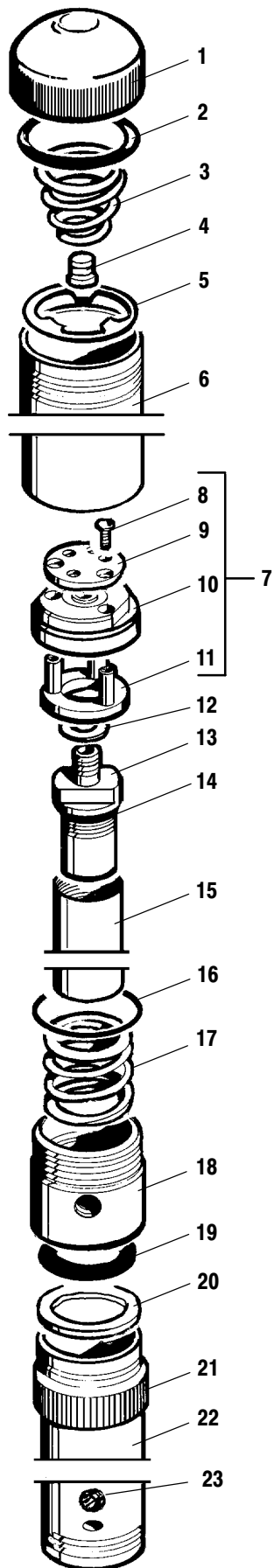

FIGURE 6

ITEM	DESCRIPTION (Size in inches)	QTY	PART NO.
✓	Items included in service kit		861034
1	Cap	1	
✓ 2	"O" Ring (3/32" x 2-5/16" o.d.)	1	
3	Spring	1	873119
4	Button	1	
5	Washer	1	
6	Cylinder	1	
✓ 7	Spacer & Piston Assembly	1	
8	Screw (#4 - 40 x 3/8")	3	
9	Valve Plate	1	
10	Piston Assembly	1	
11	Valve Spacer	1	
✓ 12	Gasket	1	
13	Plunger Tip	1	873120
14	"O" Ring (1/8" x 1-1/4" o.d.)	1	
15	Plunger	1	873121
✓ 16	"O" Ring (3/32" x 2-1/16" o.d.)	1	
17	Spring	1	873122
18	Pump Body	1	873247
✓ 19	"O" Ring (.275" x 1.837" o.d.)	1	
20	Washer	1	
21	Lock Ring	1	
22	Separating Tube	1	
23	Ground Screw	1	

### 2" AIR MOTOR REASSEMBLY

Refer to Figure 6.

1. Insert the (11) valve spacer through the bottom of the (10) piston assembly.
  2. Place the (9) valve plate on top of the piston assembly (side with three protrusions) to face (10) piston and align the three holes with the three posts of the (11) spacer.
  3. Fasten the valve plate down with the three (8) screws (this is the (7) spacer and piston assembly). Lay aside.
  4. Thoroughly grease the (19) "O" ring and place into the (18) body.
  5. Place the (20) washer in the (18) body.
  6. Screw the (22) separating tube securely to the (18) body.
  7. Tighten the (21) lock ring.
  8. Grease the (16) "O" ring and place over the threads of the (18) body.
  9. Place the (17) spring into the (18) body.
  10. Place the (15) plunger with (13) plunger tip through the (22) spacer tube and through the (18) body.
- NOTE: To prevent damage to (19) "O" ring apply light film of grease on (15 and 13) assembly.
11. Place the (12) gasket over the threads of (13) plunger tip.
  12. Screw the (7) spacer and piston assembly onto the (13) plunger tip and tighten with wrenches, using flats provided.
  13. Thoroughly grease the inside of the (6) cylinder and insert it over the (7) spacer and piston assembly.
  14. Thread the (6) cylinder on the (18) body.
  15. Screw the (1) cap, with (2) ring, (3) spring, (4) button and (5) washer, in place on the (6) cylinder and tighten with a strap wrench.

## LOWER PUMP END PARTS LIST

ITEM	DESCRIPTION (Size in inches)	QTY	PART NO.
24	Tip	1	
25	Tube and Guide	1	873128
26	Pump Body	1	873248
27	Upper Piston Rod	1	873129
28	Inner Suction Tube	1	873130
▲ 29	Cotter Pin (3/32" o.d. x 3/4")	1	
30	Nut (5/16" - 18)	1	
33	Suction Tube (models 812300)	1	873131
	(models 812304)	1	873201
34	Lower Piston Rod (models 812300)	1	873249
	(models 812304)	1	873363
36	Washer	1	
▲ 37	Piston (mineral filled Teflon)	1	
38	Washer	1	
39	Nut (3/8" - 24)	1	
40	Ball Stop (3/16" dia. x 1-1/4" long)	1	
41	Ball (.8125" dia.)	1	873070
42	Foot Valve Body (models 812304)	1	873202
43	Foot Valve Body (models 812300)	1	873133
44	Needle Valve (see figure 1)	1	873409
45	Nipple (1/4 - 18 N.P.T.F. - 1) (see figure 1)	1	
46	Ground Kit Assembly (not shown)	1	873067
47	4 oz Wet-Sol Plus (not shown)	1	863016
▲ 48	Spring Washer	1	
▲ 49	Female Washer	1	
▲ 50	"V" Packing (UHMW-PE)	4	
▲ 51	Male Washer	1	
▲	Items included in service kit		861089

Cotter Pin needs to be installed as shown. Flatten the head and legs.



- ☆ Use Loctite #271 threadlocker on these threads.
- ★ Use Teflon Tape and Nickel anti-Seize on these threads.

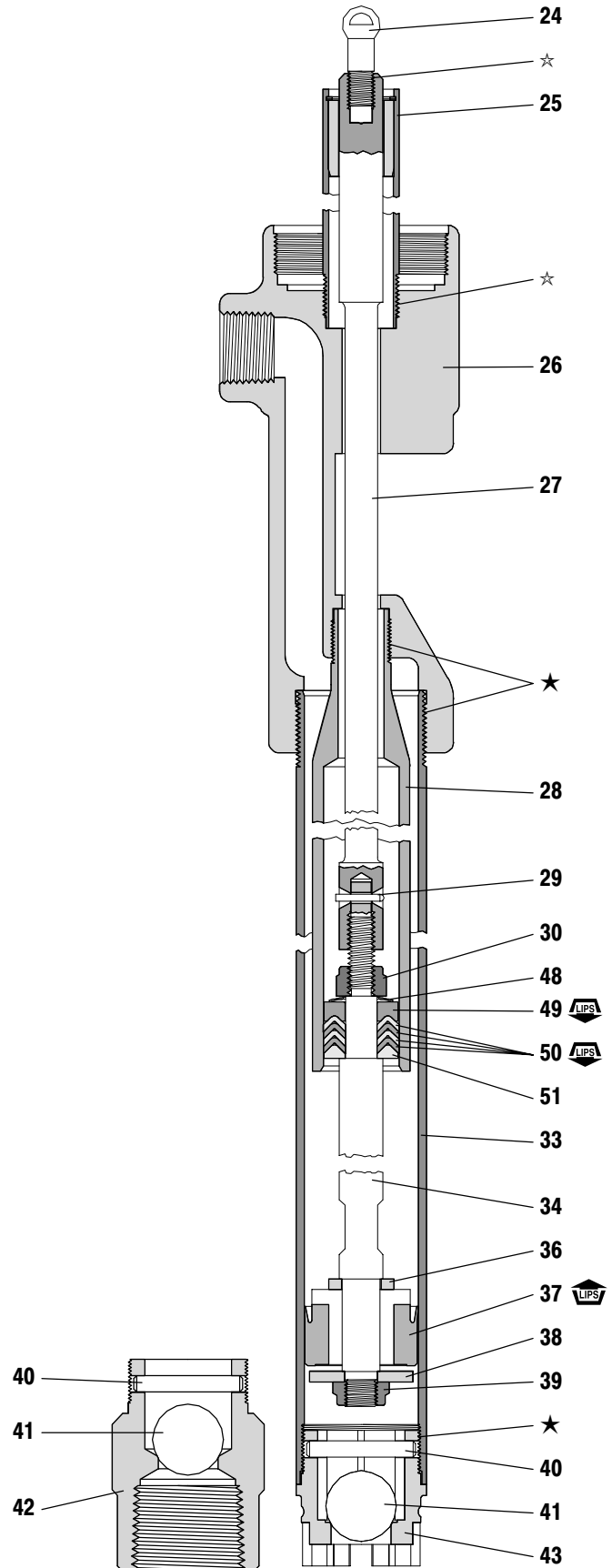

FIGURE 7

---

---

## LOWER PUMP SERVICE PROCEDURES

---

---

### LOWER PUMP DISASSEMBLY

---

Refer to Figure 7.

NOTE: All threads are right hand.

**CAUTION: Do not place wrench any place other than the knurled part of the (33) suction tube.**

1. Clamp the lower pump assembly in the vise on solid part of (26) pump body. NOTE: Do not clamp directly on outlet hole.
2. Place a pipe or strap wrench on the knurled part of the (33) suction tube and remove the suction tubes.
3. Grasp the (34) lower piston rod and remove the rod and piston assembly by pulling straight out.
4. Place a pipe or strap wrench on the knurled part of the (28) inner suction tube and remove.
5. Remove (25) tube and guide assembly with a strap wrench.
6. Clamp the (42 or 43) foot valve on flats in vise.
7. Place a pipe wrench on the knurled portion of (33) suction tube.
8. Remove (33 and 35) suction tubes from (42 or 43) foot valve.
9. Remove (42 or 43) foot valve from vise.
10. Remove (40) ball stop and (41) ball.
11. Clamp the (34) lower piston rod in the vise on flats.
12. Remove (29) cotter pin and (27) upper piston rod, remove by turning counter-clockwise.
13. Remove (30) nut, releasing (48) spring washer, (49) female washer, four (50) "V" packings and (51) male washer.
14. Remove the (39) nut, (38) washer and (37) piston.

### LOWER PUMP END REASSEMBLY

---

Refer to Figure 7.

**CAUTION:** Apply Loctite Nickel anti-seize compound to all stainless steel threads unless the service manual calls for Loctite 271 threadlocker.

1. Clamp the (34) lower piston rod on flats in vise, put the (36) washer and (37) piston in place as shown (lips up).
2. Put the (38) washer and (39) nut in place.
3. Assemble (51) male washer, four (50) "V" packings (lips down), (49) female washer (lips down) and (48) spring washer to (34) lower piston rod.
4. Assemble (30) lock nut to (34) lower piston rod and tighten.
5. Thread the (27) upper piston rod into (34) lower piston rod until the cotter pin holes line up.
6. Insert (29) cotter pin and bend legs apart (flatten legs and head). **CAUTION:** Be sure to flatten cotter pin, as shown in cross section, to prevent damage to packings.
7. Clamp on (26) pump body.
8. Thoroughly grease the inside of the (28) inner suction tube and thread securely into the (26) pump body.
9. Thoroughly grease the (37 and 50) packings, insert the (27) upper piston rod through the (28) inner suction tube and (26) pump body, (24) tip end first.
10. Thoroughly grease the inside of the (33 and 35) suction tubes.
11. Place the (33 and 35) suction tubes over the (37) piston and thread into the (26) pump body.
12. Place the (41) ball into the (42 or 43) foot valve. Insert the (40) ball stop into the (42 or 43) foot valve.
13. Thread the (42 or 43) foot valve into the (33 or 35) suction tube.
14. Tighten the lower pump section by placing a bar in the bottom slot in the (43) foot valve or a wrench on the flats of (42) foot valve.
15. Place the (25) tube and guide assembly over the (24) tip and thread into the (26) pump body.

---

---

## OPTIONAL ACCESSORIES

---

---

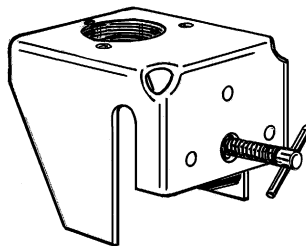

873184 BRACKET

FIGURE 8



