

MAG AA Automatic Air Assisted Airless Spray Gun



A54-71R-2 12/11

High transfer efficiency in a manifold mounted air assisted airless HVLP compliant spray gun



Time and Material Savings Benefits

The unique Binks air assisted airless tip and air cap design is now available in a new manifold automatic gun platform. The two-piece design is ideally suited for multi-gun finishing equipment such as rotary machines, reciprocators, or fixed chain-on-edge systems located in high production environments. Fluid and air connections, as well as a patented in-line filter design are located in the manifold, providing quick and easy removal of the gun for periodic maintenance. In addition to the highly transfer efficient Binks AA spray technology, the Binks MAG AA Automatic features time and material saving advantages including:

- Integrated in-line fluid filter (patented) – no need to remove the gun body when changing filters

- Reduced chance of color contamination.
- Solvent resistant high grade piston o-rings for longer life.
- Modular design for quick and easy replacement
- Cross platform design characteristics with low pressure HVLP model
- Easily mounts to other gun base configurations
- Component cartridge design for quick and easy repairs
- Superior transfer efficiency
- Reduced overspray
- Lower booth maintenance costs
- Reduced bounceback
- Longer wear part service life

Typical applications include wood finishing, leather tanning, metal furniture and fixture manufacturing, fabricated metal manufacturing, and recreational products.

Triggering Speed

CYLINDER AIR PRESSURE PSI (MPA, BAR)	FLUID PRESSURE (MPA, BAR)	MSEC FULLY OPEN	MSEC FULLY CLOSED
50 (0,34,3.4)	600 (4.2, 42)	60	60
50 (0,34,3.4)	1800 (12.4, 124)	60	60
50 (0,34,3.4)	4000 (28, 280)	60	60

Specifications

Maximum Air Pressure:
100 psi/6.8 bar

For HVLP compliance: 20 psi inlet pressure delivers 10 psi air cap pressure at 8 cfm air volume

Maximum Fluid Pressure:
4000 psi/275 bar

Minimum/Maximum Cylinder Actuating Pressure: 50 psi/3.4 bar (min.), 100 psi/6.8 bar (max.)

Gun Body: Stainless Steel, Aluminum

Fluid Path: Stainless Steel

Fluid Shut Off Type: UHMW Seat (std.), Tungsten Carbide Seat (opt.)

Fluid Inlet and Outlet Size:
1/4" NPT(f) thread

Air Inlet Size:

Atomizing Air: 1/4" NPT(F) manifold body, 1/4" NPT x 1/4" NPS(M) fitting

Fan Air: 1/4" NPT(F) manifold body, 1/4" soc head plus (M) fitting

Cylinder Air: 1/8" NPT(F) manifold body, 1/8" NPT x 1/4" O.D. tube fitting

Gun Weight: 2.5 lbs. (1.1 kg)

Gun Mounting Hole: 1/2" dia.

MAG AA Automatic Air Assisted Airless Spray Gun

Repair & Cleaning Kit

PART #	DESCRIPTION
20-6750-K10	Kit of 10 O-rings (for AA4 air cap)
54-4994	Cleaning Kit (provided with gun): includes one standard stiff nylon pipe cleaning brush, full-size nylon brush, tip cleaner, and Binks Gunners Mate Lubricant
54-5303	Standard Performance Seal Kit
54-5304	Piston Collet Repair Kit
54-5307	High Performance Seal Kit
54-5305	Optional Mount "K" Kit: includes adapter plate assembly
54-5306	CEFLA Fluid Fitting Kit
54-5315	Piston Assembly AA Gun
54-5399	Single Bolt CEFLA Adapter Kit

Fluid Seat

PART #	DESCRIPTION
54-4926	Standard UHMW Fluid Seat
54-4960	Optional Tungsten Carbide Fluid Seat

Fluid Filter

PART #	DESCRIPTION
54-1835	100 Mesh Filter

Air Caps

PART #	DESCRIPTION
AA-2 - 54-4980	Thin to Medium Materials
AA-4 - 54-4978	Medium to Heavy Materials

Accessories

PART #	DESCRIPTION
54-4997	HVLP Test Gauge AA2
54-5022	HVLP Test Gauge AA4
54-380	Gun Mounting Bracket

How to Order the MAG AA

Automatic Spray Gun

MAG AA Automatic Spray Gun **with manifold, tip, and air cap** order part number

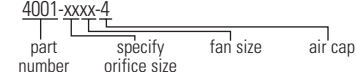

MAG AA Automatic Spray Gun **less manifold with tip**

and air cap order part number

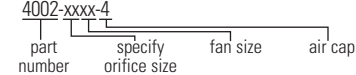

MAG AA Automatic Spray Gun **less manifold, tip, and air cap** order part number 4002-0000-0

For additional tips, order by part number

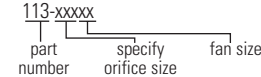

See spray tip selection chart for orifice size and fan size required

Airless Spray Tip - Fluid Flow Rate*

ORIFICE SIZE (INCHES)	500 PSI OZ./MIN.	1000 PSI OZ./MIN.	1500 PSI OZ./MIN.
VERY THIN - Wash Primers, Dyes, Stains, Solvents			
.009	5.1	7.1	8.2
.011	8.1	11.5	13.6
.013	11.7	17	19.9
THIN - Sealers, Lacquers, Primers, Ink, Zinc Chromate			
.015	16.5	23.3	27.8
.017	21	30.2	35.9
MEDIUM - Lacquers, Synthetics, Enamels, Varnishes			
.019	26.6	37.8	45.6
.021	32.8	45.8	56.8
.024	39.7	56.1	68.7
.027	50.4	71.2	87.2

Flow rate of fluid materials through spray tip, oz./min.
* Based on 1000 PSI with water. Actual results may vary, depending on material viscosity.

Spray Tip Selection Charts

PART #	ORIFICE SIZE	FAN SIZE	PART #	ORIFICE SIZE	FAN SIZE
113-00702	.007	1" - 2"	113-01706	.017	4" - 6"
113-00704	.007	2" - 4"	113-01708	.017	6" - 8"
113-00706	.007	4" - 6"	113-01710	.017	8" - 10"
113-00708	.007	6" - 8"	113-01712	.017	10" - 12"
113-00902	.009	1" - 2"	113-01714	.017	12" - 14"
113-00904	.009	2" - 4"	113-01716	.017	14" - 16"
113-00906	.009	4" - 6"	113-01718	.017	16" - 18"
113-00908	.009	6" - 8"	113-01906	.019	4" - 6"
113-00910	.009	8" - 10"	113-01908	.019	6" - 8"
113-00912	.009	10" - 12"	113-01910	.019	8" - 10"
113-01104	.011	2" - 4"	113-01912	.019	10" - 12"
113-01106	.011	4" - 6"	113-01914	.019	12" - 14"
113-01108	.011	6" - 8"	113-01916	.019	14" - 16"
113-01110	.011	8" - 10"	113-01918	.019	16" - 18"
113-01112	.011	10" - 12"	113-02110	.021	8" - 10"
113-01114	.011	12" - 14"	113-02112	.021	10" - 12"
113-01304	.013	2" - 4"	113-02114	.021	12" - 14"
113-01306	.013	4" - 6"	113-02116	.021	14" - 16"
113-01308	.013	6" - 8"	113-02118	.021	16" - 18"
113-01310	.013	8" - 10"	113-02410	.024	8" - 10"
113-01312	.013	10" - 12"	113-02412	.024	10" - 12"
113-01314	.013	12" - 14"	113-02414	.024	12" - 14"
113-01316	.013	14" - 16"	113-02416	.024	14" - 16"
113-01506	.015	4" - 6"	113-02418	.024	16" - 18"
113-01508	.015	6" - 8"	113-02710	.027	8" - 10"
113-01510	.015	8" - 10"	113-02712	.027	10" - 12"
113-01512	.015	10" - 12"	113-02714	.027	12" - 14"
113-01514	.015	12" - 14"	113-02716	.027	14" - 16"
113-01516	.015	14" - 16"	113-02718	.027	16" - 18"
113-01518	.015	16" - 18"			

◆ Based on 1000 PSI with water. Actual results may vary, depending on material viscosity.

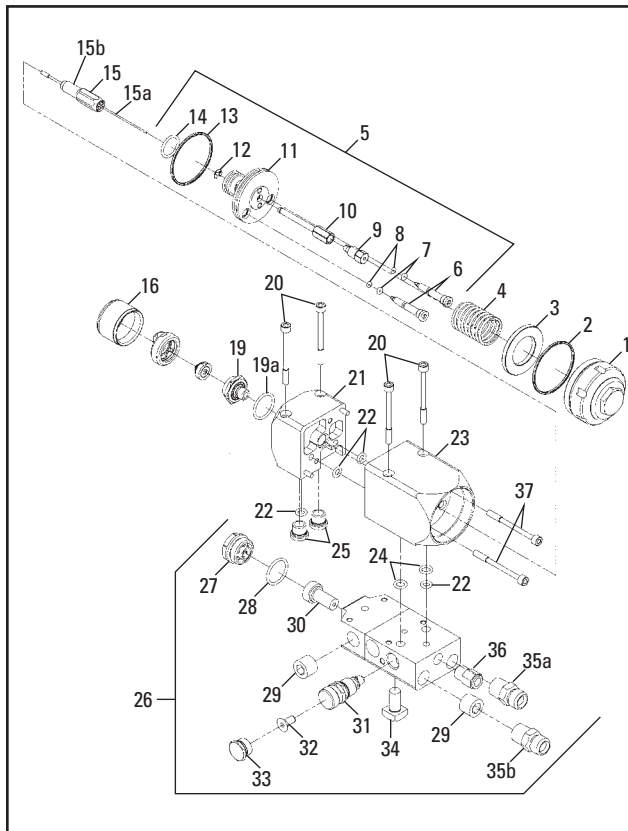

Parts List

ITEM NO.	PART NO.	DESCRIPTION	QTY.	ITEM NO.	PART NO.	DESCRIPTION	QTY.
1	54-5330	End Cap.....	1	24	20-3467	O-Ring (2-010)	2
2	20-6783	▲ O-Ring (2-029) White.....	1	25	54-5326	Fluid Manifold Port Plug	2
3	54-5331	Piston Impact Ring	1	26	54-5335	Air/Fluid Inlet Junction Assembly.....	1
4	54-5332	Piston Return Ring	1	27	54-5340	Filter Retainer Assembly ..	1
5	54-5315	Piston Assembly.....	1	28	20-5921	● O-Ring (2-017)	1
6	54-5318	▲ Atomizing Air Valve	2	29	20-6131	1/4 NPT Plug Hex Socket HD S.S.	2
7	20-6785	● O-Ring (2-004) White.....	2	30	54-1835	100 Mesh Filter Assembly.....	1
8	20-6786	▲ O-Ring (2-003) White.....	2	31	54-3720	Side Port Assembly	1
9	54-5316	▲ Collet Locknut.....	1	32	20-6748	★ Screw 10-32 x 1/4 Flathead Allan HD Pltd	1
10	54-5317	▲ Wire Collet	1	33	102-2839	★ Side Port Plug.....	1
11	54-5320	▲ Piston Body.....	1	34	20-1359-1	★ Screw Sq HD 5/16-18 x 5/8	1
12	20-6757	▲ Retaining Ring (Roto Clip E-15-55)	1	35a	57-13	1/4 NPS x 1/4 NPT DM Nipple	2
13	20-6783	▲ O-Ring (2-029) White Same as Item 2	1	35b	57-13	★ Optional Setup (Same as 35a)	
14	20-6784	▲ O-Ring (2-015)	1	36	54-4945-10	Tube Connector (Qty. Pak) (1/8 NPT(W) x 1/4 Tubing)	1
15	54-5310	Fluid Cartridge Assembly	1	37	20-6782	Allen Skt. Hd. 8-32 x 1-3/4 Lg.	2
15a	54-5312	Wire-Ball Assembly.....	1				
15b	54-4962	Rear Packing Assembly....	1				
16	54-4955	Air Nozzle Retaining Ring	1				
19	54-4926	Fluid Seat Assembly (UHMW) Optional (54-4960) Carbide.....	1				
19a	20-6037	■ O-Ring	1				
20	54-5333	Retaining Cap Screw	6				
21	54-5325	Gun Head	1				
22	20-4615-5	● O-Ring (2-008) (Qty. Pak)	4				
23	54-5324	Automatic Piston Housing..	1				

● Available as part of Rebuild Kit 54-5307 High Performance Seal Kit.
▲ Available as part of Piston Assembly 54-5355.
▲ Available as part of Piston Collet Repair Kit 54-5304.
■ Available as part of 20-6037-K10 Soft Seal Kit (10 rings).
★ Available in 54-5308 Kit.