



# 7500 PSI Airless Spray Gun

For trained, professional use only!

Maximum working pressure: 7500 PSI – 517 BAR – 51.7 Mpa

Models 1108-7500-2 & 1108-7500-4

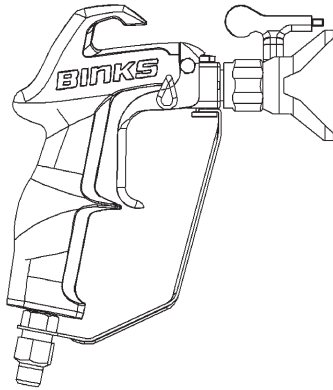

**!! SAFETY, OPERATING AND MAINTENANCE INSTRUCTIONS INSIDE!!**

Read all warnings and operating information inside

**SAVE THIS MANUAL FOR FUTURE REFERENCE**

Contact your local Binks representative for additional copies of this manual

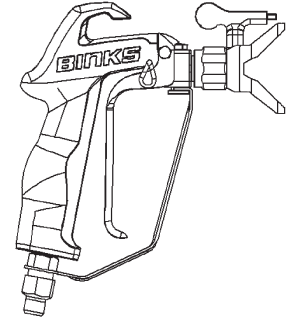

The following instructions provide the necessary information for the proper operation and preventative maintenance of the **BINKS Pit Bull** 7500 PSI Airless Spray Gun. It is the customer's responsibility to have all operators and service personnel read and understand this manual. Please read and understand all information in this document in order to safely operate your new spray gun.

### SPECIFICATIONS:

Maximum Fluid Pressure: 7500 psi / 517 bar

Gun Body: Forged Aluminum

Fluid Path: Anodized Aluminum

Fluid Inlet: ¼-18 NPS (m)

Gun Weight: 580 g



**EYE HAZARD:** Failure to wear safety glasses with side shields could result in serious injury or blindness. All operators and bystanders must always wear safety glasses with side shields that conform to ANSI Standard Z87.1 or European Norm 156.



**HAZARD: INJECTION INJURY** – a high pressure stream produced by this equipment can pierce the skin and underlying tissues, leading to a serious injury and possible amputation. See a physician immediately.

**DO NOT TREAT AN INJECTION INJURY AS A SIMPLE CUT!** Injection can lead to amputation. See a physician immediately.

### SAFETY PRECAUTIONS :

**KEEP CLEAR OF NOZZLE.** Do not exceed maximum working pressure of 7500 PSI ( 517 BAR, 51.7 Mpa). The maximum operating range of the gun is 7500 PSI/517 BAR fluid pressure.

### PREVENTION:

**NEVER** Aim the gun at any part of the body.

**NEVER** Allow any part of the body to touch the fluid stream. **DO NOT** allow body to touch a leak in the fluid hose.

**NEVER** Put hand in front of the gun. Gloves will not provide protection against an injection injury.

**ALWAYS** lock the gun trigger, shut the pump off, and release all pressure before servicing, cleaning the tip or guard, changing the tip, or leaving unattended. Pressure will not be released by turning off the motor. The PRIME/SPRAY valve must be turned to PRIME to relieve the pressure. Refer to the *PRESSURE RELIEF PROCEDURE* described in the pump manual.

**ALWAYS** Keep the tip guard in place while spraying. The tip guard provides some protection, but is mainly a warning device.

**ALWAYS** Remove the spray tip before flushing or cleaning the system.

The paint hose can develop leaks from wear, kinking, and abuse. A leak can inject material into the skin. Inspect the hose before each use.

**NEVER** Use a spray gun without a trigger lock and trigger guard in place and in good working order.

All accessories must be rated at 7500 PSI (517 BAR) or higher. This includes spray tips, guns, extensions, and hose.

### NOTE TO PHYSICIAN:

Injection into the skin is a traumatic injury. It is important to treat the injury as soon as possible. **DO NOT DELAY** treatment to research toxicity. Toxicity is a concern with some coatings injected directly into the blood stream. Consultation with a plastic surgeon or reconstructive hand surgeon may be advisable.



**HAZARD: EXPLOSION OR FIRE** – Solvent and paint fumes can explode or ignite. Severe injury and/or property damage can occur.

Replaces  
Part Sheet  
77-5519R

Part  
Sheet  
77-5519R-1

#### PREVENTION:

Provide extensive exhaust and fresh air introduction to keep the air within the spray area free from accumulation of flammable vapors.

Avoid all ignition sources such as static electricity sparks, electrical appliances, flames, pilot lights, hot objects, and sparks from connecting and disconnecting power cords or working light switches.

Do not smoke in spray area.

Fire extinguisher must be present and in good working order.

Place pump at least 25 feet (7.6 m) away from the spray object in a well ventilated area. Add more hose if necessary. Flammable vapors are often heavier than air. Floor area must be extremely well ventilated. The pump may contain arcing parts that emit sparks and can ignite vapors.

The equipment and objects in and around the spray area must be properly grounded to prevent static sparks.

Use only conductive or grounded high pressure fluid hose. Gun must be grounded through hose connections.

Power cords must be connected to a grounded circuit.

Always flush unit into a separate metal container, at low pump pressure, with spray tip removed. Hold gun firmly against side of container to ground container and prevent static sparks.

Follow the material and solvent manufacturer's warnings and instructions.

Use extreme caution when using materials with a flashpoint below 70° F (21° C). Flashpoint is the temperature that a fluid can produce enough vapors to ignite.

Plastic can cause static sparks. Never hang plastic to enclose a spray area. Do not use plastic drop cloths when spraying flammable materials.

Use lowest possible pressure to flush equipment.



**HAZARD: EXPLOSION HAZARD DUE TO INCOMPATIBLE MATERIALS – will cause severe injury or property damage.**

#### PREVENTION:

Do not use materials containing bleach or chlorine.

Do not use halogenated hydrocarbon solvents such as bleach, mildewcide, methylene chloride and 1,1,1 – trichloroethane. They are not compatible with aluminum.

Contact your coating supplier about the compatibility of material with aluminum.



**HAZARD: HAZARDOUS VAPORS – Paints, solvents, insecticides, and other materials can be harmful if inhaled or come in contact with the body. Vapors can cause severe nausea, fainting, or poisoning.**

#### PREVENTION:

Use a respirator or mask if vapors can be inhaled. Read all instructions supplied with the mask to be sure it will provide the necessary protection.

Wear protective eyewear.

Wear protective clothing as required by coating manufacturer.



**HAZARD: GENERAL – Can cause severe injury or property damage.**

#### PREVENTION:

Read all instructions and safety precautions before operating equipment.

Always disconnect the motor from the power supply before working on the equipment.

Follow all appropriate local, state, and national codes governing ventilation, fire prevention, and operation.

The United States Government Safety Standards have been adopted under the Occupational Safety and Health Act (OSHA). These standards, particularly part 1926 of the Construction Standards should be consulted.

Use only manufacturer authorized parts. User assumes all risks and liabilities when using parts that do not meet the minimum specifications and safety devices of the pump manufacturer.

Before each use, check all hoses for cuts, leaks, abrasion, or bulging of cover. Check for damage or movement of couplings. Immediately replace the hose if any of these conditions exist. Never repair a paint hose.

Replace it with another grounded high-pressure hose.

All hoses, swivels, guns, and accessories must be pressure rated at or above the maximum operating pressure range of the airless sprayer.

Do not spray outdoors on windy days.

Wear protective clothing to keep paint off skin and hair.

### **WARNING**

**The following are general WARNINGS related to the setup, use, grounding, maintenance and repair of this equipment.**

**FIRE AND EXPLOSION HAZARD – Flammable fumes, such as solvents and paint fumes, in work area can ignite or explode. To help prevent fire and explosion:**

Use equipment only in well ventilated area. Provide fresh air ventilation to avoid the buildup of flammable fumes from the material being sprayed or from the solvent.

Eliminate all ignition sources; such as pilot lights, cigarettes, portable electric lamps, and plastic drop cloths (potential static arc).

Keep work area free of debris; including solvent, rags, and gasoline.

Sprayers generate sparks. When flammable liquid is used in or near sprayer or for flushing or cleaning, keep sprayer at least 25 feet (7.6m) away from explosive vapors.

Electrically disconnect all equipment in the spray area. Do not plug or unplug power cords or turn lights on or off when flammable fumes are present.

Ground equipment and conductive objects in work area. Ground object being sprayed.

If there is static sparking or you feel a shock, **stop operating immediately**. Do not use equipment until you identify and correct the problem.

Keep a fire extinguisher in the work area.

#### SKIN INJECTION HAZARD

High pressure fluid from spray gun, hose leaks, or ruptured components will pierce skin. This may look like just a cut, but it is a serious injury that can cause amputation. **Seek immediate surgical treatment. Inform the physician as to what type of material was injected.**

Do not point gun at anyone or any part of the body.

Do not put your hand or fingers over the spray tip.

Do not stop or deflect leaks with your hand, body, glove or rag.

Do not spray without tip guard and trigger guard installed.

Engage trigger lock when not spraying.

Follow pressure relief procedure for your sprayer when you stop spraying and before cleaning, checking or servicing your equipment.

Tighten all fluid connections before operating equipment.

Check all hoses, tubes, and couplings daily. Replace all worn, damaged, or loose parts immediately.

#### EQUIPMENT MISUSE HAZARD

This equipment is for professional use only.

Read and understand all instructional manuals, tags, and labels before operating equipment.

Use equipment only for its intended purpose. If you are unsure of its purpose, call your local BINKS distributor.

Misuse can cause death or serious injury.

Do not exceed the maximum working pressure or temperature rating of the lowest rated system component. See the technical data in all equipment manuals.

Use fluids and solvents that are compatible with your equipment wetted parts. See technical data in all equipment manuals. Read fluid and solvent manufacturer's warnings. For complete information about your material, request a MSDS from your distributor or retailer.

Check your equipment daily. Do not alter or modify your equipment. Repair or replace worn or damaged parts immediately with genuine **BINKS**  Replacement Parts only.

Do not alter or modify this equipment.

Use equipment only for its intended purpose. Call Binks for more information.

Route hoses and cables away from traffic areas, sharp edges, moving parts and hot surfaces.

Do not kink or over bend hoses or use hoses to pull equipment.

Use genuine **BINKS PITBULL** hoses. If provided, do not remove the spring guards from hoses, these are on the hoses to prevent rupture from kinking at the connectors.

Keep children and animals away from work area.

Comply with all applicable safety regulations.

Do not operate equipment when fatigued or under the influence of drugs or alcohol.

**TOXIC FLUID HAZARD**

Know the specific hazards of the fluid you are using. This information is on the MSDS for the material that is being used. Read all fluid manufacturer's warnings.

Store hazardous fluids in approved containers only. Dispose of all hazardous fluids in accordance with all state, local and national guidelines.

Wear the appropriate protective clothing, gloves, eyewear and respirator.

**PRESSURIZED ALUMINUM PARTS HAZARD**

Do not use 1,1,1-trichloroethane, methylene chloride, other halogenated hydrocarbon solvents or fluids containing such solvents in this equipment. Such use could result in a serious chemical reaction, with the possibility of explosion, which could cause death, serious injury and/or substantial property damage.

**GROUNDING AND ELECTRIC REQUIREMENTS**

The sprayer and gun must be grounded. Grounding reduces the risk of static and electric shock by providing an escape wire for the electrical current due to static build up or in the event of a short circuit. Follow the grounding instructions included in the equipment manual provided with all your spray equipment. Additional grounding instructions for your **BINKS PITBULL** Airless Spray Gun are provided:

Ground your **BINKS PITBULL** Airless Spray Gun through connection to a properly grounded fluid hose and pump.

**BINKS PITBULL Airless Spray Gun**

Attach grounded **BINKS PITBULL** fluid hose here

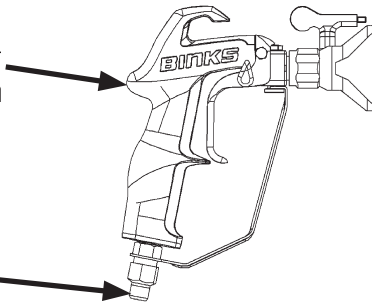

**SET UP INSTALLATION**

**WARNING**

Never attempt to assemble, change, or clean the gun, tip, or tip guard without first relieving pressure from the spray system. Follow the "PRESSURE RELIEF PROCEDURE" in the sprayer's equipment manual.

**WARNING**

Always use tip safety guard for added protection against injection. Beware that the guard alone will not prevent injection. NEVER cut off tip guard! Always engage gun trigger lock when the gun is not in use. Before servicing equipment, consult all equipment manuals and follow all warnings.

Note: **BINKS PITBULL** Airless Spray Gun Safety Tip Guards for the 7500 PSI (517 BAR) gun are gray in color.

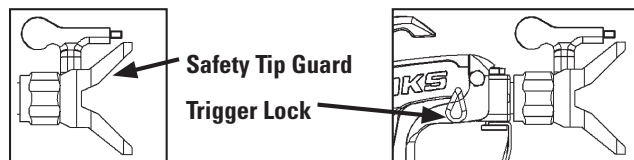

**BINKS PITBULL PROFESSIONAL AIRLESS SPRAY GUN**

7500 PSI (517 BAR) MODEL: 1108-7500-2 AND 1108-7500-4

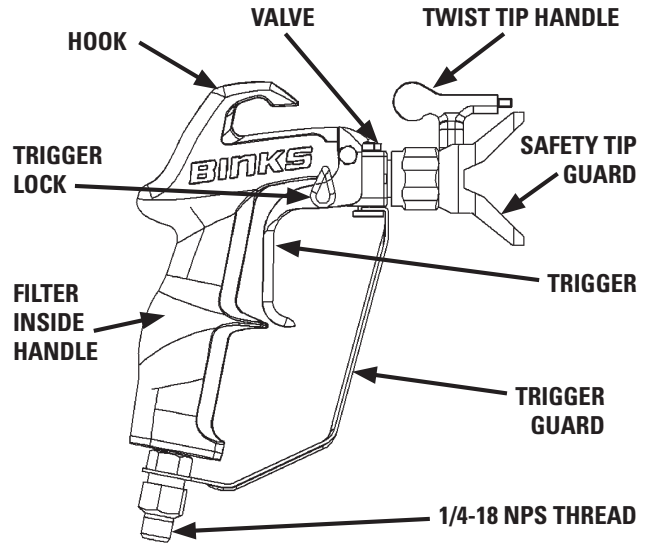

If you are using a genuine **BINKS PITBULL** tip, follow the instructions below to install the guard and tip. If you are using a different tip, follow the installation instructions provided with the tip that you are using.

**INSTALLATION OF THE TIP AND GUARD**

- A. Make sure that the tip and tip guard are rated for use at 7500 PSI. (Genuine **BINKS PITBULL** parts will be gray in color.)
- B. Use seal alignment tool on **BINKS PITBULL** tip handle to insert seal and pressure gasket into back of guard, turn to align with tip shaft opening.
- C. Insert tip into opening on **BINKS PITBULL** guard. NOTE: Narrow end of tip handle should be in forward position for spraying.
- D. Thread the guard onto gun head until it stops. Tighten slightly with wrench – DO NOT OVER TIGHTEN.

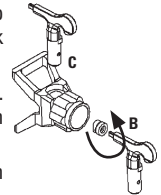

**CONNECTION TO THE HOSE**

Attach a properly grounded fluid hose to the fluid hose connection fitting (1/4-18 NPS thread) on the bottom of the handle of your spray gun. Use two (2) wrenches – one on the gun and one on the hose. Tighten securely.

**Trigger Lock Positions**

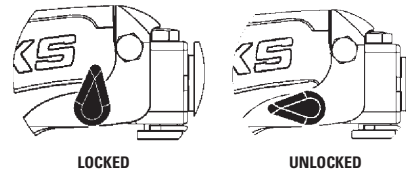

**OPERATION**

- A. Make sure your tip is in the spray position.
- B. Start your sprayer following the instructions provided in the equipment owner's manual.
- C. Pull trigger to achieve flow through gun.
- D. Adjust the fluid pressure on the sprayer until proper atomization is achieved. Always spray at the lowest pressure necessary to get the desired atomization.

**TIP CLOGS**

If you are using a Genuine **BINKS PITBULL** spray tip, follow the instructions below to clear a clogged tip. If you are using a different tip, follow the instructions included in the equipment manual provided with that tip.

- A. Engage Trigger Lock. Rotate tip handle 180° to the reverse position.
- B. Unlock trigger. Point the gun into a bucket holding the gun nose away

- from you. Trigger the gun briefly to expel the clog.
- C. Engage Trigger Lock. Rotate tip handle 180° to the spray position.
  - D. Unlock trigger. Spray a test to be sure the clog is completely expelled.
- NOTE: If clog is not completely expelled after following the above steps, repeat steps 1-4 until the clog is completely cleared.**

**SEAL REMOVAL**

Follow the pressure relief procedure as instructed in your equipment owner’s manual. Engage trigger lock. Remove guard from gun head. Push seal and gasket out rear of guard using narrow end of tip handle.

**FILTER CLEANING AND REPLACEMENT**

**IMPORTANT! YOU MUST RELIEVE ALL FLUID PRESSURE FROM YOUR ENTIRE SPRAY SYSTEM INCLUDING THE SPRAYER, HOSE AND GUN BEFORE DISCONNECTING THE HOSE!**

Disconnect fluid hose from base of gun. Using a 3/4” wrench, remove the Inlet Fitting from the bottom of the gun handle. Be sure to retain the Filter Seal which is located between the Filter and Inlet Fitting. Remove Filter from the bottom of the handle. Install a new or cleaned Filter, open side down, through one new Filter Seal and into the gun handle. Place a new or cleaned Filter Seal into the Inlet Fitting. Replace the gun inlet connection using a 3/4” wrench to tighten it.

**NOTE: The adapter nipple at the base of the forging is not removable.**

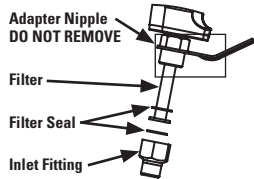

**REPLACING THE VALVE**

**IMPORTANT! YOU MUST RELIEVE ALL FLUID PRESSURE FROM YOUR ENTIRE SPRAY SYSTEM INCLUDING THE SPRAYER, HOSE AND GUN BEFORE DISCONNECTING THE HOSE!**

Engage Trigger Lock. Disconnect the fluid hose from the base of the gun. Remove Tip and Safety Tip Guard. Disengage Trigger Lock. Loosen Trigger Screw and Nut. Remove Trigger Screw and Nut. Slide Trigger back. Use a 3/8 socket wrench to remove Valve. Clean or replace Valve. Insert Valve into gun forging. Make sure that the Seat Seal on the Valve is secure to the seat. Use a 3/8 socket wrench and torque Valve to 120 inch-pounds. Move Trigger forward. Replace Trigger Nut and Screw. Engage Trigger Lock.

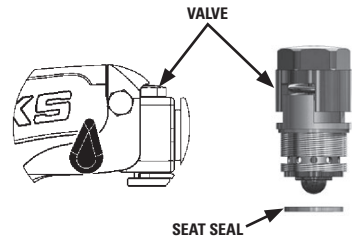

**CLEANING AND MAINTENANCE**

**CLEAN DAILY**

Maintaining a clean gun is important to ensure trouble-free operation and extend the service life of your gun. Always flush the gun thoroughly after each use and store in a warm, dry location. DO NOT leave the gun or any of its parts in water or solvents.

Always flush gun outside if possible and at least 25 ft (7.5 m) away from sprayer.

Area must be free of flammable vapors.

Always flush at minimum pressure. Always remove tip and guard.

Static electricity buildup may result in fire or explosion in the presence of flammable vapors.

Always hold the gun firmly against a grounded, metal container when flushing.

**TROUBLE SHOOTING**

Spray gun distance from work surface should be at a point where maximum fan pattern is evident. This distance is normally 8 to 14 inches.

Excessive fluid pressure will distort the spray pattern. Spray at the lowest acceptable pressure.

Hour-glass and tails on spray patterns normally indicate too low a fluid pressure for the nozzle tip orifice size or the material is too viscous or thick. Increase the pressure or thin the material.

Distorted patterns may be the result of worn or plugged tips. Clean (see tip clogs) or replace the spray tip.

Airless spray guns are either on or off. You cannot feather with airless guns as you can with air atomized equipment.

Successive strokes may require overlapping. Typical overlap is 30%.

**PARTS DRAWING FOR YOUR BINKS P100 BULL PROFESSIONAL AIRLESS SPRAY GUN**

7500 PSI (517 BAR) MODEL: 1108-7500-2 AND 1108-7500-4

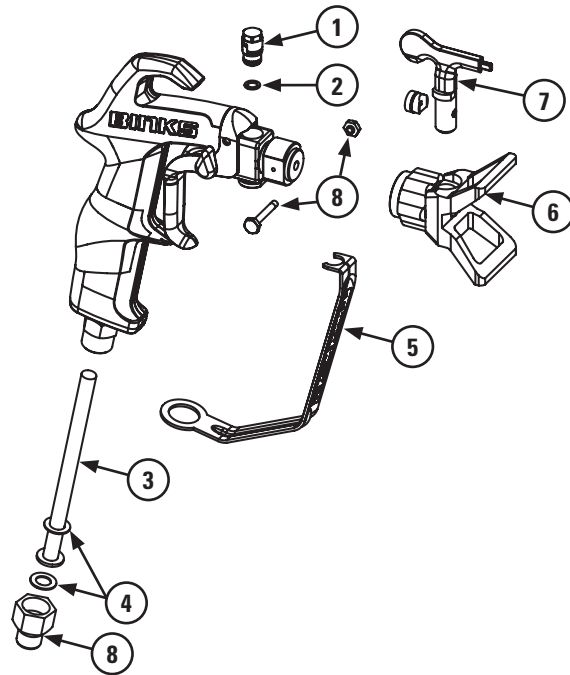

ITEM NO.	PART NO.	DESCRIPTION
1	1108-3575	VALVE CARTRIDGE
2	54-5711-K5	VALVE SEAL KIT
3	54-5730-K5	FLUID FILTER 60 MESH KIT
3 (OPTIONAL)	54-5731-K5	FLUID FILTER 100 MESH KIT
4	54-5709-K10	FILTER SEAL KIT
5	54-5721	TRIGGER GUARD
6	1108-75B	SAFETY TIP GUARD
7	9-XXX-75	SPRAY TWIST TIP – SEE SELECTION CHART
8	54-5760	AIRLESS GUN REPAIR KIT (SCREW, NUT, FILTER ADAPTER)

## BINKS PIT BULL SPRAY TIP SELECTION CHART

PART NUMBER 9-XXX-75 (Tips rated for use at 7500 psi)  
All of the following tips will have a grey tip handle

	6" spray pattern	8" spray pattern	10" spray pattern	12" spray pattern	14" spray pattern
.007" orifice	307				
.009" orifice	309	409	509		
.011" orifice	311	411	511	611	
.013" orifice	313	413	513	613	713
.015" orifice	315	415	515	615	715
.017" orifice		416	517	617	717
.019" orifice		419	519	619	
.021" orifice			521	621	
.023" orifice			523	623	
.025" orifice			525		
.027" orifice				627	
.031" orifice				631	
.035" orifice		435		635	

## BINKS PIT BULL ACCESSORIES

ORDER NUMBER	DESCRIPTION
72-2332	Swivel Adapter 1/4" M x 1/4" F
72-2333	Swivel Adapter 3/8" M x 1/4" F
52-5208	30" Airless Tip Extension
52-5209	60" Airless Tip Extension

## BINKS PIT BULL AIR HOSE

ORDER NUMBER	DESCRIPTION
71-4870	Hose Whip 1/4" F x 3/8" M 3 ft, 10,000 psi working pressure
71-4840	Hose 1/4" x 25 ft 10,000 psi working pressure
71-4841	Hose 1/4" x 50 ft 10,000 psi working pressure
71-4860	Hose 3/8" x 25 ft 8,000 psi working pressure
71-4861	Hose 3/8" x 50 ft 8,000 psi working pressure

The Spray Gun models listed in the following declaration of conformity may be used in some potentially explosive atmospheres ONLY when the special conditions for safe installation and operation have been followed as expressed in this user manual (Part Sheet). These models are approved to ATEX regulations 94/9/EC, protection level: II 2 G X: Suitable for use in Zones 1 and 2.

### EC Declaration of Conformity

Manuf. By: ITW Industrial Finishing  
195 Internationale Blvd.  
Glendale Heights, IL 60139

Type/Series: Handheld Spray Guns

Model: 1108-7500-2, 1108-7500-4

The equipment to which this document relates is in conformance with the following standards or other normative references:

**EN ISO 12100-1&2:2003** and **BS EN 1953:1999** and thereby conform to the protection requirements of Council Directive 98/37/EC relating to Machinery Safety Directive, and;

**EN 13463-1:2001**, Council Directive **94/9/EC** relating to **Equipment and Protective Systems for use in Potentially Explosive Atmospheres**, protection level **II 2 G X**.

Approved By: Paul Micheli Date: December 3, 2009  
Paul Micheli, ITW Industrial Finishing



### WARRANTY

This product is covered by Binks' 1 Year Limited Warranty.

**Binks Worldwide Sales and Service Listing: [www.binks.com](http://www.binks.com)**



North American Office  
ITW Industrial Finishing  
195 Internationale Blvd.  
Glendale Heights, IL 60139  
630-237-5000  
[www.binks.com](http://www.binks.com)

Toll Free Customer Service  
and Technical Support  
800-992-4657  
Toll Free Fax  
888-246-5732